



EWELLIX

EWELLIX Linear Actuators

CAHB

Product Data Sheet

We pioneer motion

SCHAEFFLER

Contents

1	CAHB	4
2	CAHB-10	6
3	CAHB-20A	14
4	CAHB-20E, CAHB-20S	20
5	CAHB-21E, CAHB-21S	27
6	CAHB-22E, CAHB-22S	35
7	Electrical specification for CAHB..E.....	43
8	Electrical specification for CAHB..S.....	46
9	Attachment options for CAHB..E and CAHB..S.....	50
10	Functional overview of CAHB..S.....	54
11	CAHB-30A	68
12	CAHB-31N	74
13	CAHB – Environmental tests.....	80

1 CAHB

The CAHB series with 7 families of linear drives is virtually maintenance-free, self-locking up to twice the rated load and has a protection class up to IP69K/IP66M. It is suitable for low, medium and high loads in mobile applications.

Additional design options are available including limit switches, positioning feedback and manual override.

The smart CAHB..S versions offer unique features at a competitive cost with integrated control system and advanced functions.

Characteristics

New Smart CAHB..S versions

- integrated control system with I/O and CAN bus SAE J1939
- movement with soft start/stop and parallel movement of 2 linear drives
- monitoring of the main linear drive functions with diagnostics

For all versions

- electronic or mechanical overload protection and thermal protection
- long stroke and high speed
- high holding force up to 20000 N
- low backlash
- Absolute or incremental Position feedback and limit switches option
- Manual override option
- IP protection classes IP69K/IP66M with ventilation
- anti-rotation device, free spinning (option for E design)
- Stainless steel push tube with anti rotation, free spinning attachment and corrosion protected metal parts
- wide temperature range (-40 °C to 85 °C)
- high efficiency
- virtually maintenance-free
- mechanical, electrical and climatic tests

Benefits

- higher productivity with fast and smooth movement
- easy and quick integration into customer devices
- higher reliability and protection
- cost effective and virtually maintenance-free
- Monitoring and onboard diagnostics

CAHB performance overview

1 CAHB performance overview

Family	Version	Rated force	Speed (up to)	max. stroke	Power supply	Voltage				Integrated control system
		N	mm/s	mm		V				
CAHB-10 ... A	CAHB-10...1A	120	56	300	DC	12	24	-	-	No
	CAHB-10...2A	240	30	300	DC	12	24	-	-	No
	CAHB-10...3A	500	16	300	DC	12	24	-	-	No
	CAHB-10...4A	750	10	300	DC	12	24	-	-	No
	CAHB-10...5A	1000	8	300	DC	12	24	-	-	No
	CAHB-10...6A	1500	8	300	DC	12	24	-	-	No
CAHB-20 ... A	CAHB-20...1A	1500	33	610	DC	12	24	-	-	No
	CAHB-20...2A	2500	17	610	DC	12	24	-	-	No
CAHB-20 ... E/S	CAHB-20...1E or S	1500	31	700	DC	12	24	48	24 to 48	Yes
	CAHB-20...2E or S	2500	23	700	DC	12	24	48	24 to 48	Yes
	CAHB-20...3E or S	4500	13	700	DC	12	24	48	24 to 48	Yes
CAHB-21 ... E/S	CAHB-21...1E or S	1500	51	700	DC	12	24	48	24 to 48	Yes
	CAHB-21...2E or S	2500	41	700	DC	12	24	48	24 to 48	Yes
	CAHB-21...3E or S	4500	23	700	DC	12	24	48	24 to 48	Yes
CAHB-22 ... E/S	CAHB-22...1E or S	2300	57	700	DC	12	24	48	24 to 48	Yes
	CAHB-22...2E or S	3500	45	700	DC	12	24	48	24 to 48	Yes
	CAHB-22...3E or S	6800	22	610	DC	12	24	48	24 to 48	Yes
	CAHB-22...4E or S	10000	13	450	DC	12	24	48	24 to 48	Yes
CAHB-30 ... A	CAHB-30...1A	1500	26	610	AC	115 (60 Hz)		230 (50 Hz)		No
	CAHB-30...2A	2300	13	610	AC	115 (60 Hz)		230 (50 Hz)		No
CAHB-31 ... N	CAHB-31...1N	2300	57	610	AC	115 (60 Hz)		230 (50 Hz)		No
	CAHB-31...2N	4500	28	610	AC	115 (60 Hz)		230 (50 Hz)		No
	CAHB-31...3N	6000	15	610	AC	115 (60 Hz)		230 (50 Hz)		No

2 CAHB-10

1 CAHB-10

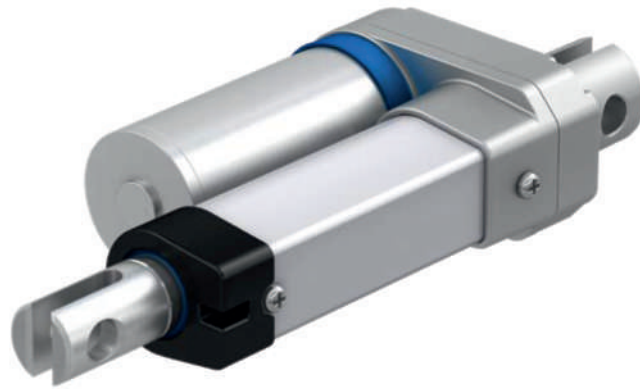

001CF02A

Benefits

- designed and tested under demanding conditions
- reliable and cost-effective
- reduced overall set time
- virtually maintenance-free

Characteristics

- compact and robust design, IP66S/IP69K, wide temperature range and corrosion resistant
- integrated limit switches, optional absolute or incremental positioning feedback
- integrated thermal protection

3 Mounting CAHB-10...1 to CAHB-10...6

		Unit	Ø A	Ø B
Rod end with bore	A	mm	6.4 (0/+0.1)	6.4 (0/+0.1)
Rod end with bore	B	mm	8.0 (0/+0.1)	8.0 (0/+0.1)
Fork head with hole	C	mm	10.1 (0/+0.1)	10.1 (0/+0.1)

4 Tolerances CAHB-10

Type	Tolerance Stroke	Tolerance Retracted length
	mm	mm
CAHB-10...1, CAHB-10...2	(-1, +5)	(-5, +1)
CAHB-10...3, CAHB-10...4	(-3, +3)	(-3, +3)
CAHB-10...5, CAHB-10...6	(-4, +2)	(-2, +4)

5 Calculation of the retracted lengths L, CAHB-10...1 to CAHB-10...6

Stroke	mm	50	100	150	200	250	300
Retracted length L with rod end front + rod end rear	mm	158	209	260	311	362	413
Retracted length L with rod end front + fork head rear	mm	165	216	267	318	369	420
Retracted length L with fork head front + rod end rear	mm	172	223	274	325	376	427
Retracted length L with fork head front + fork head rear	mm	179	230	281	332	383	434

Optional potentiometer and absolute analog value

2

3 Dimensions

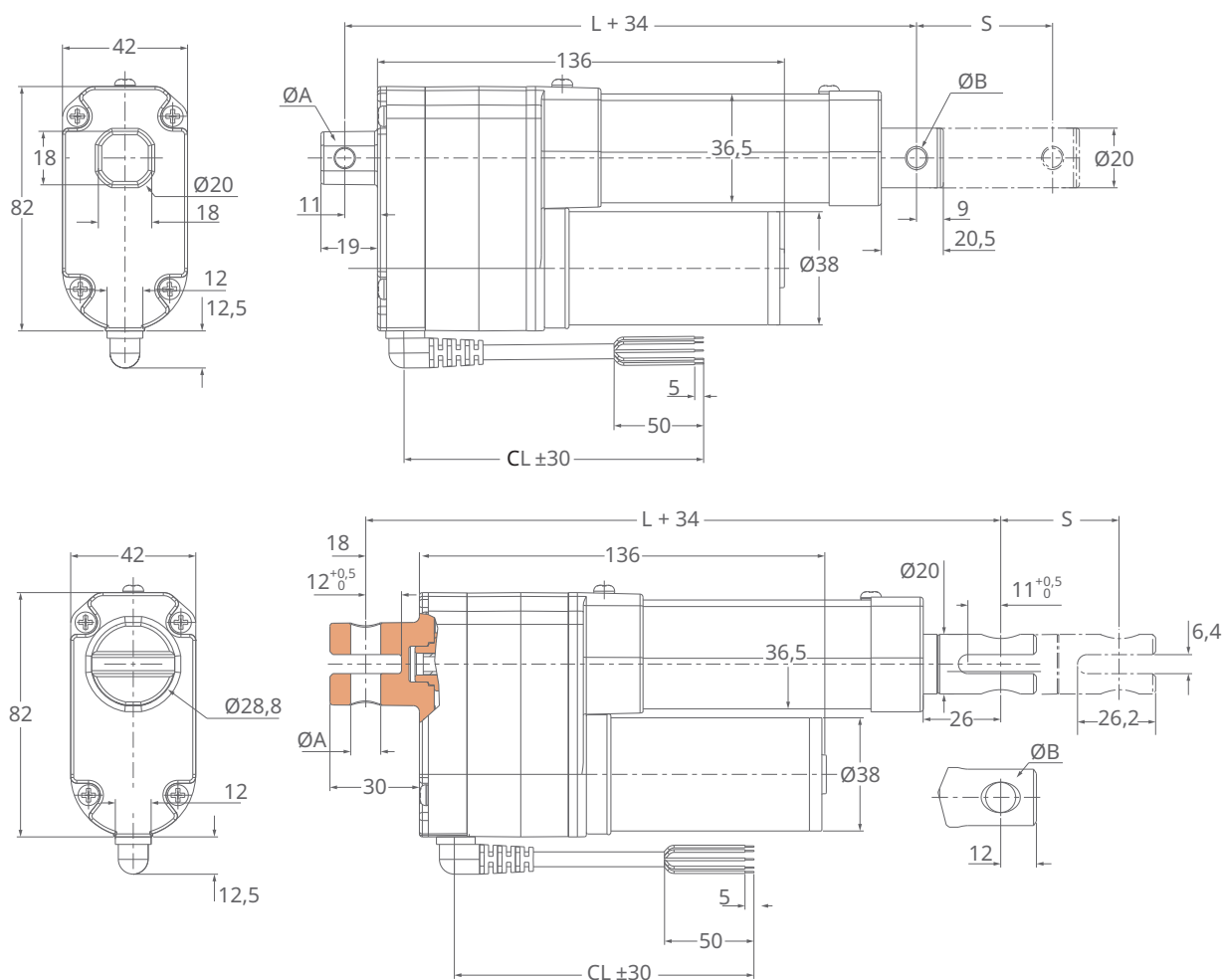

001CA1FB

6 Mounting CAHB-10...1 to CAHB-10...6

		Unit	$\varnothing A$	$\varnothing B$
Rod end with bore	A	mm	6.4 (0/+0.1)	6.4 (0/+0.1)
Rod end with bore	B	mm	8.0 (0/+0.1)	8.0 (0/+0.1)
Fork head with hole	C	mm	10.1 (0/+0.1)	10.1 (0/+0.1)

7 Tolerances CAHB-10

Type	Tolerance Stroke	Tolerance Retracted length
	mm	mm
CAHB-10...1, CAHB-10...2	(-1, +5)	(-5, +1)
CAHB-10...3, CAHB-10...4	(-3, +3)	(-3, +3)
CAHB-10...5, CAHB-10...6	(-4, +2)	(-2, +4)

8 Calculation of the retracted lengths L, CAHB-10...1 to CAHB-10...6

Stroke	mm	50	100	150	200	250	300
Retracted length L with rod end front + rod end rear	mm	192	243	294	345	396	447
Retracted length L with rod end front + fork head rear	mm	199	250	301	352	403	454
Retracted length L with fork head front + rod end rear	mm	206	257	308	359	410	461
Retracted length L with fork head front + fork head rear	mm	213	264	315	366	417	468

Performance diagrams

4 Speed-load diagram CAHB-10

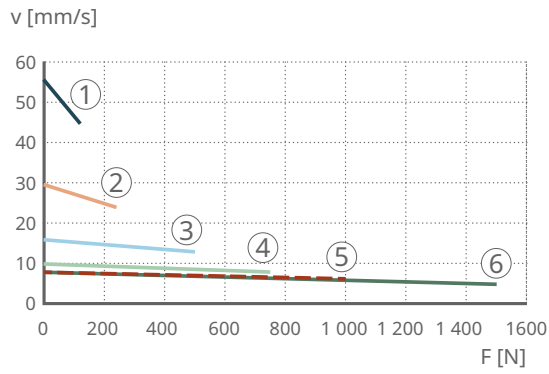

001D1C96

1	CAHB-10...1	2	CAHB-10...2
3	CAHB-10...3	4	CAHB-10...4
5	CAHB-10...5	6	CAHB-10...6
v	Speed	F	Load

5 Current-load diagram CAHB-10

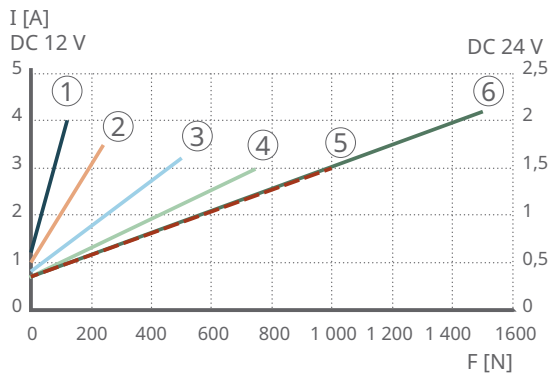

001D1C98

1	CAHB-10...1	2	CAHB-10...2
3	CAHB-10...3	4	CAHB-10...4
5	CAHB-10...5	6	CAHB-10...6
I	Current	F	Load

Encoder resolution

9 Encoder resolution

Characteristic	Unit	CAHB-10...1	CAHB-10...2	CAHB-10...3	CAHB-10...4	CAHB-10...5	CAHB-10...6
Encoder resolution	mm/pulse	0.3	0.15	0.075	0.05	0.0375	0.0375

Potentiometer resolution

10 Potentiometer resolution CAHB-10...1 to CAHB-10...6

Stroke	mm	50 - 80	80 - 160	160 - 300
Minimum resistance value of potentiometer	Ω	700 - 1300	700 - 1300	700 - 1300
Potentiometer resolution	Ω /mm	100	50	16.6

Absolute analog output signal

11 Absolute analog output signal CAHB-10...1 to CAHB-10...6

Stroke	mm	50 - 80	80 - 160	160 - 300
Initial value versus L position	V	0.5	0.5	0.5
Resolution	mm	0.024	0.049	0.146
Position feedback change	V/mm	0.05	0.025	0.0083

2

Attachment orientation (see order designation "Attachment orientation")

6 Attachment orientation

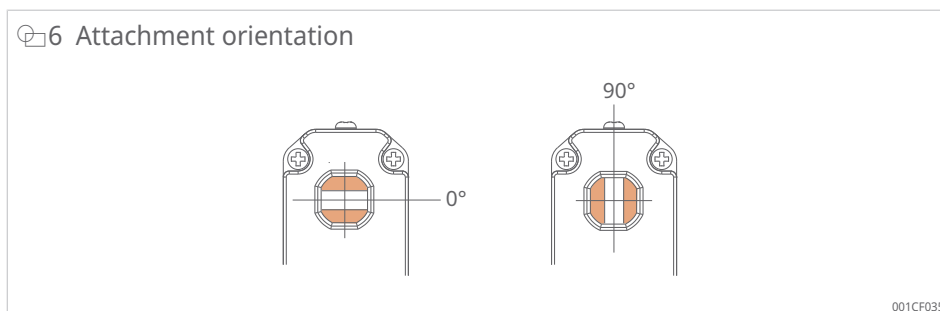

001CF035

Wiring diagrams

7 Basic configuration DC 12 V, DC 24 V

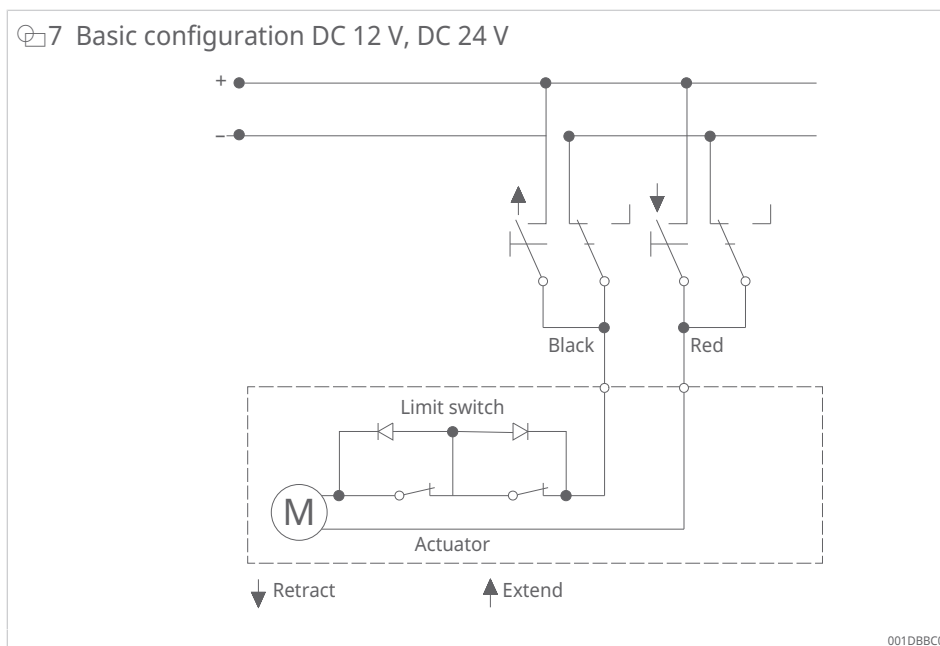

001DBBC0

8 2-Hall encoder DC 12 V, DC 24 V

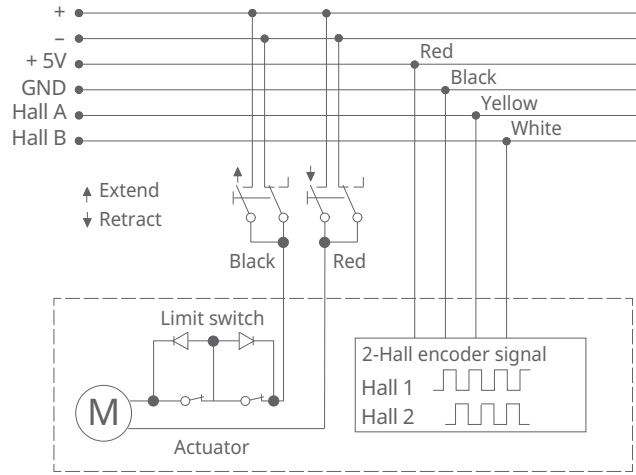

001DBBF0

9 Potentiometer DC 12 V, DC 24 V

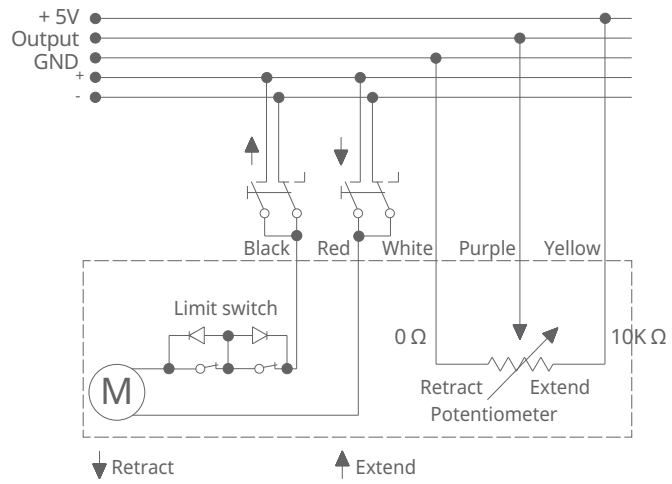

001DBBE0

10 Absolute analog output signal DC 12 V, DC 24 V

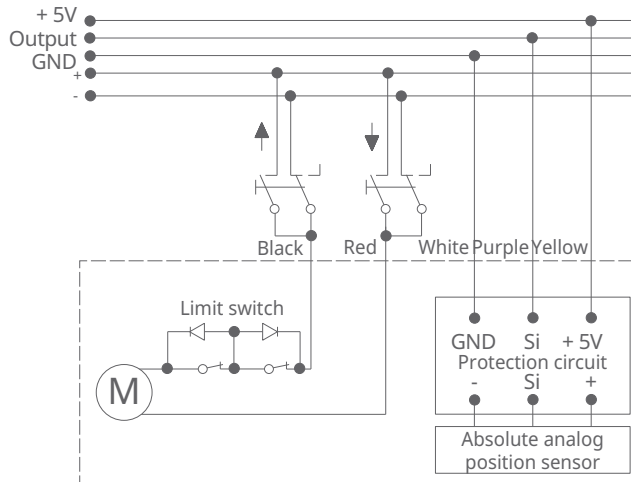

001DBBD0

Ordering key

11 Order designation for CAHB-10

CAHB-10-A1A-050158-A A A 0 A-000

Type**Voltage**

A	DC 12 V
B	DC 24 V

Load

1	120 N
2	240 N
3	500 N
4	750 N
5	1000 N
6	1500 N

Design

A	TR12 screw
X	Customization

3 × digital stroke length and 3 × digital retracted length (mm)

Stroke	Retracted length basic conf. ¹⁾	With front fork head C	With rear fork head C	With potentiometer or absolute analog output A, P
050	158	+14	+7	+34
100	209	+14	+7	+34
150	260	+14	+7	+34
200	311	+14	+7	+34
250	362	+14	+7	+34
300	413	+14	+7	+34

Degree of protection

A	Standard (IP66S/69K)
---	----------------------

Front attachment

A	Rod with hole Ø6.4 (0, +0.1) mm
B	Rod with hole Ø8 (0, +0.1) mm
C	Fork head with hole Ø10.1 (0, +0.1) mm
X	Customization

Rear attachment

A	Rod with hole Ø6.4 (0, +0.1) mm
B	Rod with hole Ø8 (0, +0.1) mm
C	Fork head with hole Ø10.1 (0, +0.1) mm
X	Customization

Hole direction of the attachments

A	0°
B	90°

Option 1: position output

0	No option
A	Absolute analog output signal
P	Potentiometer
H	2-Hall encoder

Cable length

A	600 mm without connector
B	1 000 mm without connector
C	1 500 mm without connector
D	2 000 mm without connector
E	2 500 mm without connector
F	3 000 mm without connector

Customization

X

¹⁾ Basic configuration: the retracted length with front and rear "rod with hole" attachment, without "potentiometer" and without "absolute analog output signal"

3 CAHB-20A

12 CAHB-20A



001CF036

Benefits

- compact design, tested for high stress
- robust and reliable
- thermal protection and virtually maintenance-free

Characteristics

- integrated overload and thermal protection
- robust design
- IP66
- optional potentiometer and limit switches

12 Technical information for the CAHB-20A

Characteristic	Unit	CAHB-20...1A	CAHB-20...2A
Rated push force	N	1500	2500
Rated pull force	N	1500	2500
Holding force ¹⁾	N	10000	10000
Speed (full load to no load)	mm/s	27-33	13-17
Stroke S	mm	102 to 610	102 to 610
Voltage	V DC	12 / 24	12 / 24
Rated voltage DC 12 V	A	16	14
Rated voltage DC 24 V	A	8	7
Duty cycle of operation	%	25	25
Ambient temperature	°C	-40 to +85	-40 to +85
IP protection	-	IP66	IP66
Weight (at 305-mm stroke)	kg	5.5	5.5
Color	-	Black	Black

¹⁾ The holding force is the highest load a powered-down drive can statically hold without slipping backward.

Basic configuration (dashed line for optional limit switch)

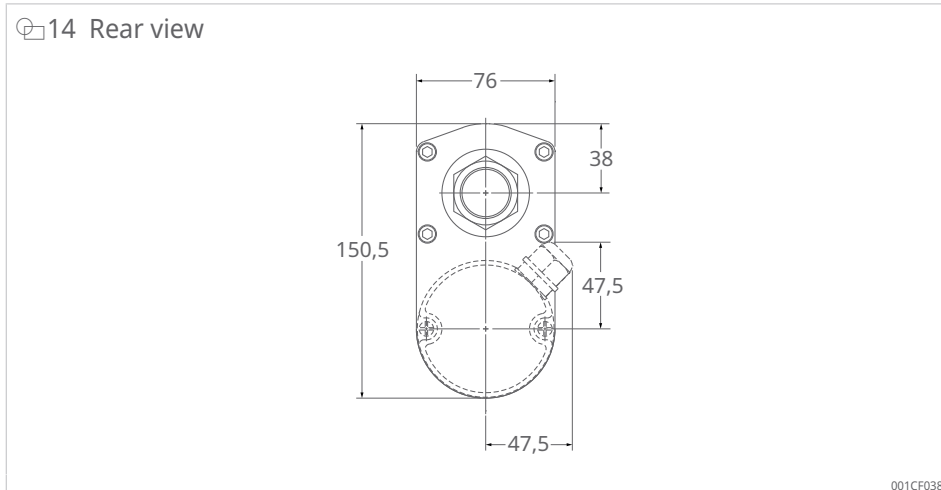
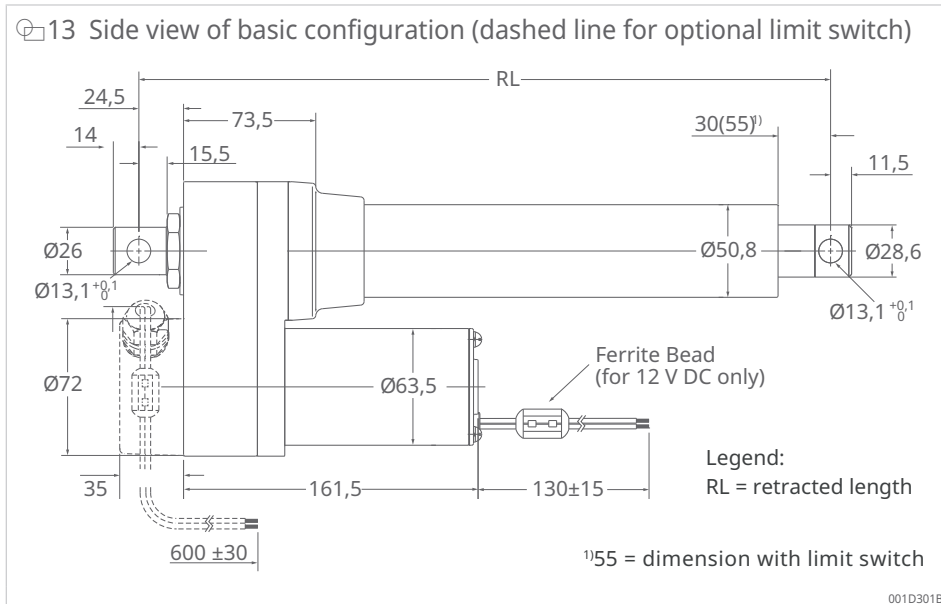
**Without limit switch:**

- RED (+) & BLACK (-) = retraction
- RED (-) & BLACK (+) = extension

With limit switch:

- RED (+) & BLACK (-) = extension
- RED (-) & BLACK (+) = retraction

13 Calculation of the installation length (RL) for CAHB-20A basic configuration

Stroke mm	Unit	With limit switch ²⁾						Without limit switch ³⁾					
		102	153	204	305	457	610	102	153	204	305	457	610
Installation length (RL)	mm	338	389	440	592	744	897	262	313	364	465	668	821

²⁾ Tolerance: S and RL = ± 5.0 mm (if $S \geq 305$ mm, $S = \pm 7.5$ mm)

³⁾ Tolerance: S = ± 2.5 mm and L = ± 3.8 mm

Performance diagrams

3

15 Speed-load diagram for CAHB-20A

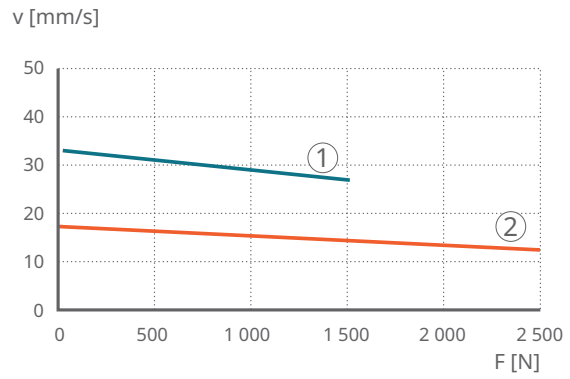

001D176D

1	CAHB-20...1	2	CAHB-20...2
v	Speed	F	Load

16 Current-load diagram for CAHB-20A

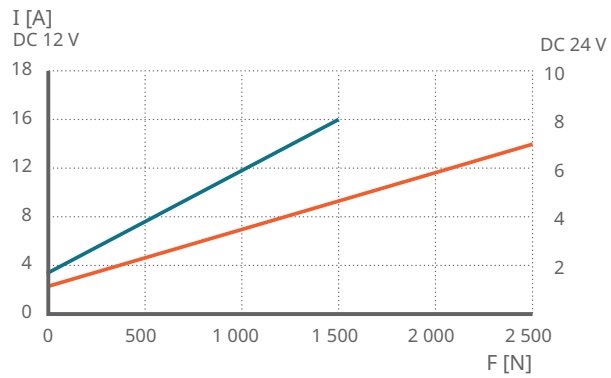

001D1770

1	CAHB-20...1	2	CAHB-20...2
I	Current consumption	F	Load

Optional potentiometer (dashed line for optional limit switch)

17 Side view of optional potentiometer (dashed line for optional limit switch)

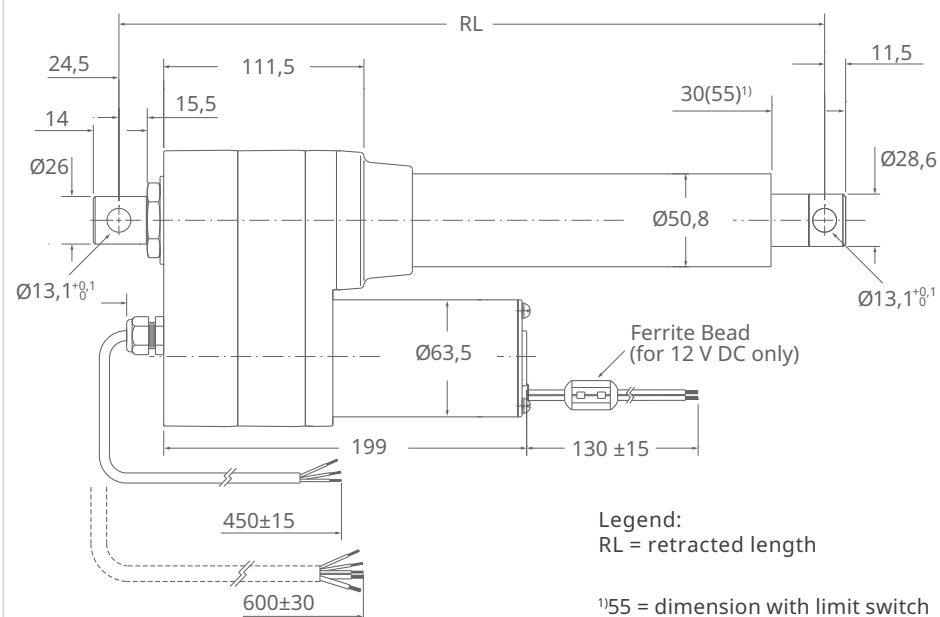

001D305B

18 Rear view

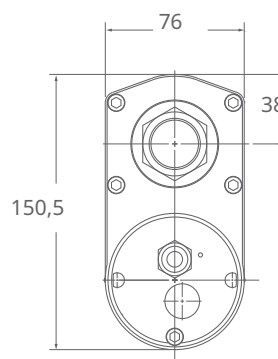

001CF03F

Without limit switch:

- RED (+) & BLACK (-) = retraction
- RED (-) & BLACK (+) = extension

With limit switch:

- RED (+) & BLACK (-) = extension
- RED (-) & BLACK (+) = retraction

14 Calculation for installation length (RL) for CAHB-20A optional potentiometer

Stroke mm	Unit	With limit switch ⁴⁾						Without limit switch ⁵⁾					
		102	153	204	305	457	610	102	153	204	305	457	610
Installation length (RL)	mm	376	427	478	630	782	935	300	351	402	503	706	859

⁴⁾ Tolerance: S and RL = ±5.0 mm (if S ≥ 305 mm, S = ±7.5 mm)

⁵⁾ Tolerance: S = ±2.5 mm and L = ±3.8 mm

15 Potentiometer resolution for CAHB-20A

Stroke	mm	102	153	204	305	457	610
Ω /mm	mm	59.0	59.0	29.5	29.5	9.84	9.84

Wiring diagrams

3

19 Connection diagram for CAHB-20A

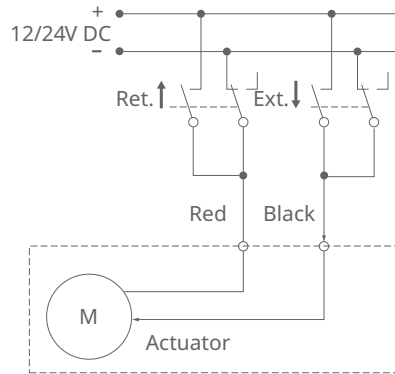

001D302B

Electrical diagrams

20 Electrical diagrams for CAHB-20A

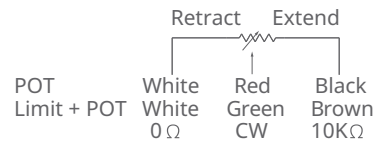

001D303B

Attachment orientation

21 Attachment orientation

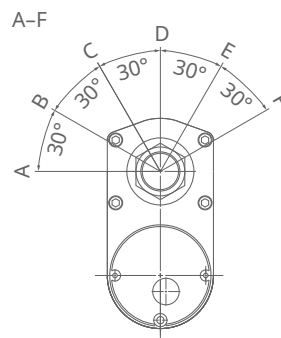

001D304B

Ordering key

22 Order designation for CAHB-20A

CAHB - 20 - A 1 A - 102 262 - A A A 0 0 0 - 000

Type

Voltage

A	DC 12 V
B	DC 24 V

Load

1	1500 N
2	2500 N

Design

A

3 × digital stroke length and 3 × digital retracted length (mm)

Stroke	Retracted length basic conf. ¹⁾	with Limit switch L	with Potentiometer P
102	262	+76	+38
153	313	+76	+38
204	364	+76	+38
305	465	+127	+38
457	668	+76	+38
610	821	+76	+38

Degree of protection

A Standard: IP66

Attachment diameter (Front and rear)

A Standard (hole: Ø13.1 mm)
 X Customization

Attachment orientation (Front and rear)

A Standard (0°)
 B 30°
 C 60°
 D 90°
 E 120°
 F 150°
 X Customization

Option 1

0 None
 L Limit switch (only for load version 2 500 N)

Option 2

0 None
 P Potentiometer

Option 3

0 None
 T Thermal protection

Customization

¹⁾ Basic configuration: the retracted length: without "limit switch", without "potentiometer"

001E01C5

The linear drives have protection clutch and EMC filter.

4 CAHB-20E, CAHB-20S

23 CAHB-20E, CAHB-20S



001CF040

Benefits

- high productivity
- reliability and safety
- saves development time
- cost effectiveness
- quick time to market (for Smart version)

Characteristics

- holding force
- overload protection
- corrosion protection and stainless steel tube
- Manual override option
- higher protection class and virtually maintenance-free

smart version features S

- integrated control system with complete motion control
- true absolute position contactless sensor
- Monitoring and on board diagnostics (force, voltage, temperature)
- I/O and CAN bus SAE J1939 communication

 16 Technical information for the CAHB-20E

Characteristic	Unit	CAHB-20E								
		12 V			24 V			48 V		
Rated push force	N	1500	2500	4500	1500	2500	4500	1500	2500	4500
Rated pull force	N	1500	2500	4500	1500	2500	4500	1500	2500	4500
Max pull/push force ¹⁾	N	2600	3800	6300	2600	3800	6300	2600	3800	6300
Holding force ²⁾	N	▶24 ⊖28								
Speed without load ³⁾	mm/s	27.0	23.5	13.5	29.0	22.0	13.0	31.0	23.0	13.0
Speed with the rated force ³⁾	mm/s	24.5	17.5	10.5	25.5	19.0	11.0	27.5	20.0	11.0
Rated voltage	V DC	12	12	12	24	24	24	48	48	48
Nominal current at rated load ³⁾	A	12.5	15	17	5	6.5	8	2.6	3.8	4.2
Nominal current (clutch activation)	A	18.4	21	22.4	6.8	8.8	10.4	4.3	5.6	5.8
Duty cycle of operation	%	10	10	10	20	20	20	20	20	20
ON time/OFF time	s	85 / 765	85 / 765	85 / 765	85 / 340	85 / 340	85 / 340	85 / 340	85 / 340	85 / 340
Stroke	mm	50 to 700	50 to 700	50 to 700	50 to 700	50 to 700	50 to 700	50 to 700	50 to 700	50 to 700
Backlash	mm	0.6	0.6	0.6	0.6	0.6	0.6	0.6	0.6	0.6
Mass at 200-mm stroke	kg	4.5	4.5	4.5	4.5	4.5	4.5	4.5	4.5	4.5
Color	-	Black	Black	Black	Black	Black	Black	Black	Black	Black
Ambient temperature ⁴⁾	°C	-40 to +85	-40 to +85	-40 to +85	-40 to +85	-40 to +85	-40 to +85	-40 to +85	-40 to +85	-40 to +85
IP protection	-	IP69K, IP66M								
Standards/EMC	-	EN 61000-6-2:2005, EN 61000-6-4:2007/A1:2011								
Salt spray test	-	ISO 9227:2012, 250 h								

¹⁾ Upper limit of the pull/push force limited by the clutch. The lower limiting value is just above the rated force. The limitation of the force will happen between these 2 limits.

²⁾ The holding force is the highest load a powered-down drive can statically hold without slipping backward. For maximum static load, refer to the "Static load" diagrams.

³⁾ The speed and current data in this list is defined at +20 °C.

⁴⁾ Full performance from 0 °C to +40 °C, for use at low temperatures (-40 °C to -25 °C) please contact Schaeffler.

17 Technical information for the CAHB-20S

Characteristic	Unit	CAHB-20S					
		12 V			24 V ... 48 V		
Rated push force	N	1500	2500	4500	1500	2500	4500
Rated pull force	N	1500	2500	4500	1500	2500	4500
Max pull/push force ⁵⁾	N	2600	3800	6300	2600	3800	6300
Holding force ⁶⁾	N	▶ 25 29					
Speed without load ⁷⁾	mm/s	27.0	23.5	13.5	29.0	22.0	13.0
Speed with the rated force ⁷⁾	mm/s	24.5	17.5	10.5	25.5	19.0	11.0
Rated voltage ⁸⁾	V DC	12	12	12	24 ... 48	24 ... 48	24 ... 48
Nominal current ⁷⁾	A	12.5	15	17	5.0 ... 2.5	6.5 ... 3.3	8.0 ... 4.0
Max. current, nominal current ⁹⁾	A	31.3	31.3	31.3	20.7 ... 10.4	20.7 ... 10.4	20.7 ... 10.4
Duty cycle ¹⁰⁾	%	10	10	10	20	20	20
ON time/OFF time	s	85 / 765	85 / 765	85 / 765	85 / 340	85 / 340	85 / 340
Stroke S	mm	50 ... 700	50 ... 700	50 ... 700	50 ... 700	50 ... 700	50 ... 700
Backlash	mm	0.6	0.6	0.6	0.6	0.6	0.6
Max. manual override torque	Nm	1.5	1.2	1.0	1.5	1.2	1.0
Max. manual override speed	min ⁻¹	1600	1600	1600	1600	1600	1600
Mass at 200-mm stroke	kg	4.8	4.8	4.8	4.8	4.8	4.8
Color	-	Black	Black	Black	Black	Black	Black
Ambient temperature ¹¹⁾	°C	-40 ... +85	-40 ... +85	-40 ... +85	-40 ... +85	-40 ... +85	-40 ... +85
IP protection	-	IP69K, IP66M					
Standards/EMC	-	See environmental performances - electrical tests					
Salt spray test	-	ISO 9227:2012, 500 h					

⁵⁾ Upper limit of the pull/push force, limited by the E-clutch.

⁶⁾ The holding force is the highest load a powered-down drive can statically hold without slipping backward. For maximum static load, refer to the "Static load" diagrams.

⁷⁾ The speed and current data in this list is defined at +20 °C, PWM 100 %

⁸⁾ Version for 12 V with DC 12-V motor, version for 24–48 V with DC 24-V motor.

⁹⁾ Max. current is the upper limit of the input current to the drive. In any circumstances, the current will not exceed to max. current.

¹⁰⁾ Duty cycle is at +20 °C.

¹¹⁾ Full performance from 0 °C to +40 °C, for use at low temperatures (-40 °C to -25 °C) please contact Schaeffler.

Performance diagrams

24 Speed-load diagram for CAHB-20E

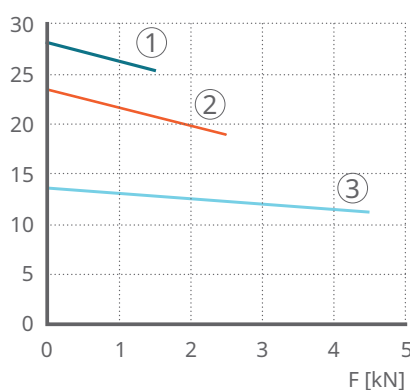

001D1771

1	CAHB-20...1E	2	CAHB-20...2E
3	CAHB-20...3E	F	Load
v	Speed		

25 Speed-load diagram for CAHB-20S

v [mm/s]

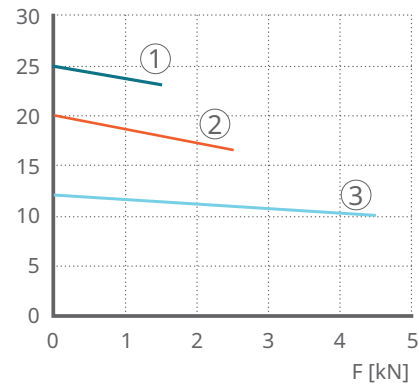

001D1779

1	CAHB-20...1S	2	CAHB-20...2S
3	CAHB-20...3S	F	Load
v	Speed		

26 Current-load diagram for CAHB-20E

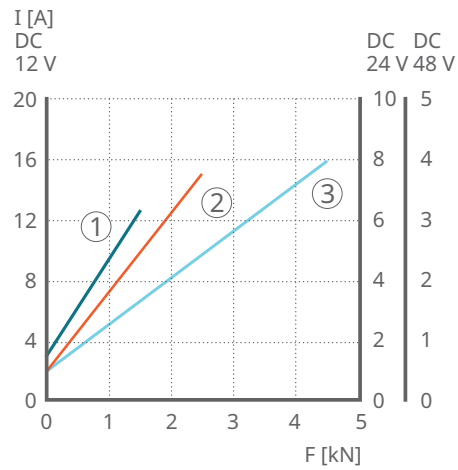

001D1776

1	CAHB-20...1E	2	CAHB-20...2E
3	CAHB-20...3E	F	Load
I	Current consumption		

27 Current-load diagram for CAHB-20S

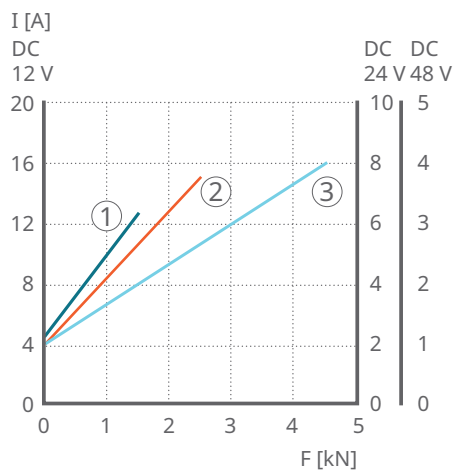

001D177A

1	CAHB-20...1S	2	CAHB-20...2S
3	CAHB-20...3S	F	Load
I	Current consumption		

28 Static load stroke length for CAHB-20E

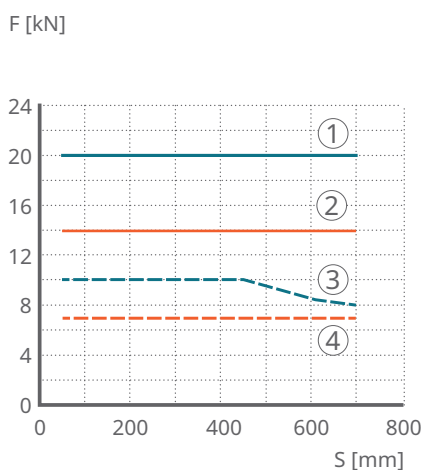

001D177B

1	Ultimate CAHB-20...E (push)	2	Ultimate CAHB-20...E (pull)
3	Recommended CAHB-20...E (push)	4	Recommended CAHB 20...E (pull)
S	Stroke	F	Load

29 Static load stroke length for CAHB-20S

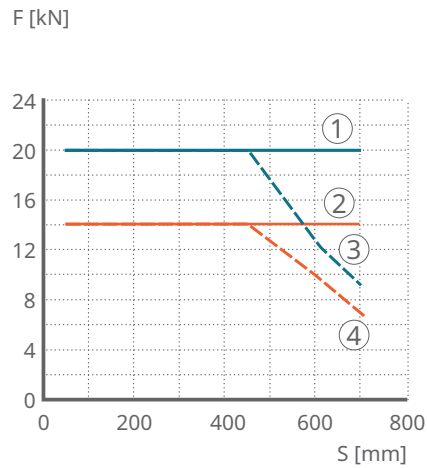

001D177D

1	Ultimate CAHB-20...S (push)	2	Ultimate CAHB-20...S (pull)
3	Recommended CAHB-20...S (push)	4	Recommended CAHB 20...S (pull)
S	Stroke	F	Load

Dimensional drawings

30 Side view dimensions for CAHB-20E, CAHB-20S

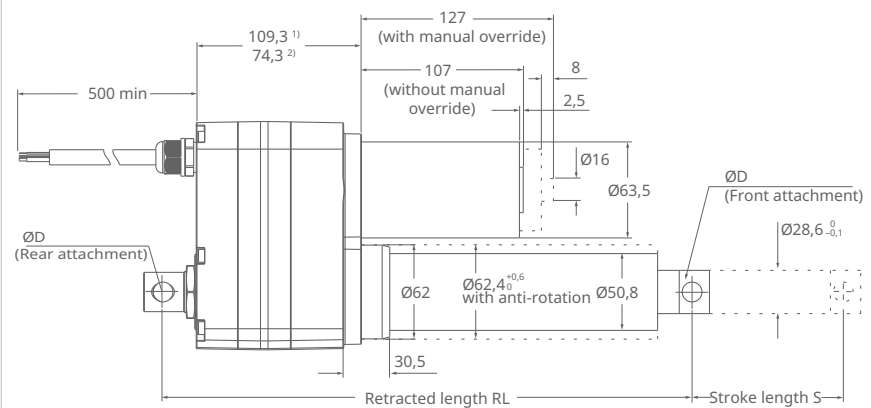

¹⁾ 109,3 for E design with position output

²⁾ 74,3 for E design without position output and S design

001D307B

31 Rear view dimensions for CAHB-20E, CAHB-20S

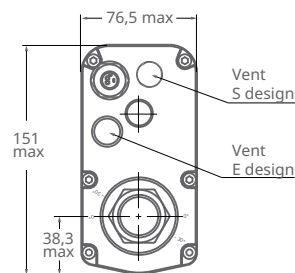

001D306B

18 Tolerances for CAHB-20E, CAHB-20S

Design	Stroke tolerance	Installation length tolerance
	mm	mm
CAHB-20E	±2	±2
CAHB-20S	±1	±1

Calculation of the installation length (RL)

19 Calculation of the installation length (RL)

Stroke	Baseline: Rod with hole attachment		Fork head attachment	Anti-rotation tube with free-spinning front attach- ment		Rod end spherical plain bearing with anti-rotation tube	
	50 ... 305	306 ... 700	50 ... 700	50 ... 305	306 ... 700	50 ... 305	306 ... 700
	mm	mm	mm	mm		mm	mm
CAHB-20E							
Installation length (RL) with no position output ¹²⁾	160+S	211+S	+12	+5	-11	+47	+19
Installation length (RL) with position output ¹³⁾	195+S	246+S	+12	+5	-11	+47	+19
CAHB-20S							
Installation length (RL)	167+S	202+S	+12	+0	+0	+43	+33

¹²⁾ 160 + 50 (stroke) + 12 (fork head attachment) + 5 (anti-rotation tube with free-spinning front attachment) = 227

¹³⁾ 246 + 400 (stroke) + 19 (rod end spherical plain bearing with anti-rotation tube) = 665

5 CAHB-21E, CAHB-21S

32 CAHB-21E, CAHB-21S



Benefits

- high productivity
- reliability and safety
- saves development time
- cost effectiveness
- quick time to market (for Smart version)

Characteristics

- high holding force
- high speed
- mechanical overload protection
- corrosion protection and stainless steel tube
- Manual override option
- higher protection class, practical, maintenance-free

smart version features S

- integrated control system with complete motion control
- true absolute position contactless sensor
- Monitoring and on board diagnostics (force, voltage, temperature)
- I/O and CAN bus SAE J1939 communication

 20 Technical information for the CAHB-21E

Characteristic	Unit	CAHB-21E								
		12 V			24 V			48 V		
Rated push force	N	1500	2500	4500	1500	2500	4500	1500	2500	4500
Rated pull force	N	1500	2500	4500	1500	2500	4500	1500	2500	4500
Max pull/push force ¹⁾	N	2500	3600	6300	2500	3600	6300	2500	3600	6300
Holding force ²⁾	N	▶32 ◀37								
Speed without load ³⁾	mm/s	49.5	37	24.0	52.5	38	22.5	51.5	41.0	23.5
Speed with the rated force ³⁾	mm/s	43	31.5	19.0	50	31.5	21.0	46.0	33.5	19.0
Rated voltage	V DC	12	12	12	24	24	24	48	48	48
Nominal current at rated load ³⁾	A	14.5	16	19	7	7.5	10.5	4.0	4.5	5.0
Nominal current (clutch activation)	A	19.2	20.2	24.8	9.1	9.3	13.7	5.6	6.1	6.4
Duty cycle ⁴⁾	%	10	10	10	20	20	20	20	20	20
ON time/OFF time	s	85 / 765	85 / 765	85 / 765	85 / 340	85 / 340	85 / 340	85 / 340	85 / 340	85 / 340
Stroke S	mm	50 to 700	50 to 700	50 to 700	50 to 700	50 to 700	50 to 700	50 to 700	50 to 700	50 to 700
Backlash	mm	0.6	0.6	0.6	0.6	0.6	0.6	0.6	0.6	0.6
Mass at 200-mm stroke	kg	4.8	4.8	4.8	4.8	4.8	4.8	4.8	4.8	4.8
Color	-	Black	Black	Black	Black	Black	Black	Black	Black	Black
Ambient temperature ⁵⁾	°C	-25 to +85	-25 to +85	-25 to +85	-25 to +85	-25 to +85	-25 to +85	-25 to +85	-25 to +85	-25 to +85
IP protection	-	IP69K, IP66M								
Standards/EMC	-	EN 61000-6-2:2005, EN 61000-6-4:2007/A1:2011								
Salt spray test	-	ISO 9227:2012, 250 h								

¹⁾ Upper limit of the pull/push force limited by the clutch. The lower limiting value is just above the rated force. The limitation of the force will happen between these 2 limits.

²⁾ The holding force is the highest load a powered-down drive can statically hold without slipping backward. For maximum static load, refer to the "Static load" diagrams.

³⁾ The speed and current data in this list is defined at +20 °C.

⁴⁾ Duty cycle: Output force and movement of the linear drive are in the same direction of travel, otherwise the duty cycle is 10 % (25 s ON/225 s OFF).

⁵⁾ Full performance from 0 °C to +40 °C, for use at low temperatures (-40 °C to -25 °C) please contact Schaeffler.

21 Technical information for the CAHB-21S

Characteristic	Unit	CAHB-21S					
		12 V			24 V ... 48 V		
Rated push force	N	1500	2500	4500	1500	2500	4500
Rated pull force	N	1500	2500	4500	1500	2500	4500
Max pull/push force ⁶⁾	N	2500	3600	6300	2500	3600	6300
Holding force ⁷⁾	N	▶32 □38					
Speed without load ⁸⁾	mm/s	49.5	37.0	24.0	52.5	38.0	22.5
Speed with the rated force ⁸⁾	mm/s	43.0	31.5	19.0	50.0	31.5	21.0
Rated voltage ⁹⁾	V DC	12	12	12	24 ... 48	24 ... 48	24 ... 48
Nominal current ⁸⁾	A	14.5	16.0	19.0	7.0 ... 3.5	7.5 ... 3.8	10.5 ... 5.3
Max. current, nominal current ¹⁰⁾	A	31.3	31.3	31.3	20.7 ... 10.4	20.7 ... 10.4	20.7 ... 10.4
Duty cycle ¹¹⁾	%	10	10	10	20	20	20
ON time/OFF time	s	85 / 765	85 / 765	85 / 765	85 / 340	85 / 340	85 / 340
Stroke S	mm	50 ... 700	50 ... 700	50 ... 700	50 ... 700	50 ... 700	50 ... 700
Backlash	mm	0.6	0.6	0.6	0.6	0.6	0.6
Max. manual override torque	Nm	1.0	1.0	1.0	1.0	1.0	1.0
Max. manual override speed	min ⁻¹	1600	1600	1600	1600	1600	1600
Mass at 200-mm stroke	kg	4.8	4.8	4.8	4.8	4.8	4.8
Color	-	Black	Black	Black	Black	Black	Black
Ambient temperature ¹⁰⁾	°C	-25 ... +85	-25 ... +85	-25 ... +85	-25 ... +85	-25 ... +85	-25 ... +85
IP protection	-	IP69K, IP66M					
Standards/EMC	-	See environmental performances – electrical tests					
Salt spray test	-	ISO 9227:2012, 500 h					

⁶⁾ Upper limit of the pull/push force, limited by the E-clutch.

⁷⁾ The holding force is the highest load a powered-down drive can statically hold without slipping backward. For maximum static load, refer to the "Static load" diagrams.

⁸⁾ The speed and current data in this list is defined at +20 °C, PWM 100 %

⁹⁾ Version for 12 V with DC 12-V motor, version for 24–48 V with DC 24-V motor.

¹⁰⁾ Max. current is the upper limit of the input current to the drive. In any circumstances, the current will not exceed to max. current.

¹¹⁾ The duty cycle is for temperatures of +20 °C and where the direction of the output force of the linear drive is in the same direction of movement as the linear drive, otherwise the duty cycle is 10 % (25 s ON/225 s OFF)

Performance diagrams

33 Speed-load diagram for CAHB-21E

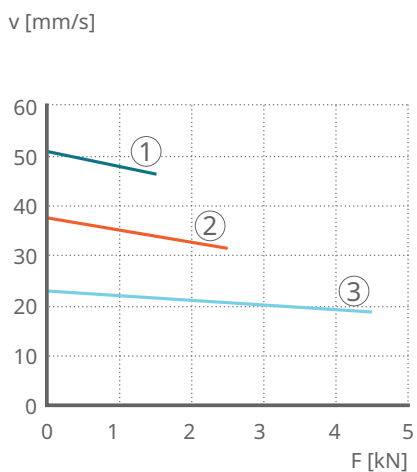

001D177F

1	CAHB-21...1E	2	CAHB-21...2E
3	CAHB-21...3E	F	Load
v	Speed		

34 Speed-load diagram for CAHB-21S

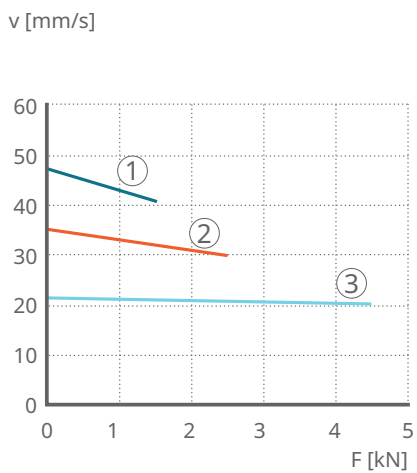

001D1789

1	CAHB-21...1S	2	CAHB-21...2S
3	CAHB-21...3S	F	Load
v	Speed		

35 Current-load diagram for CAHB-21E

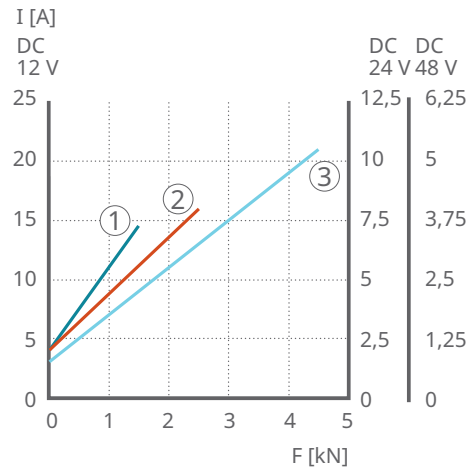

001D1784

1	CAHB-21...1E	2	CAHB-21...2E
3	CAHB-21...3E	F	Load
I	Current consumption		

36 Current-load diagram for CAHB-21S

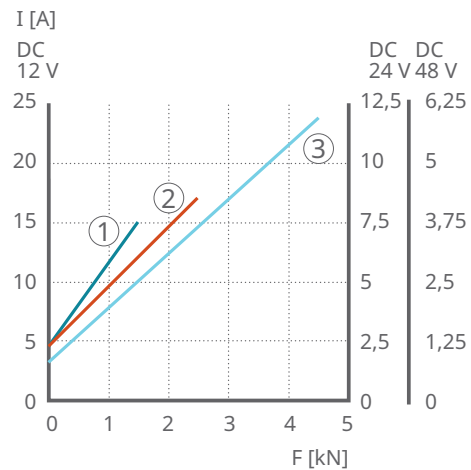

001D178A

1	CAHB-21...1S	2	CAHB-21...2S
3	CAHB-21...3S	F	Load
I	Current consumption		

37 Static load stroke length for CAHB-21E

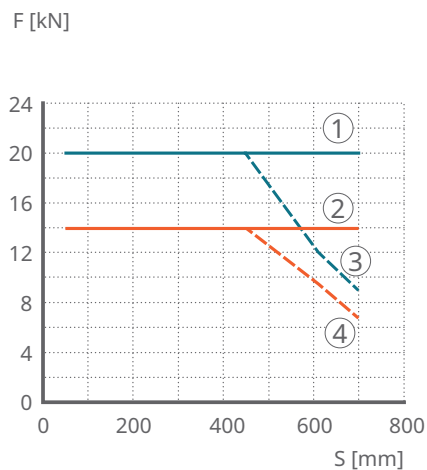

001D1787

1	Ultimate CAHB-21...E (push)	2	Ultimate CAHB-21...E (pull)
3	Recommended CAHB-21...E (push)	4	Recommended CAHB 21...E (pull)
S	Stroke	F	Load

38 Static load stroke length for CAHB-21S

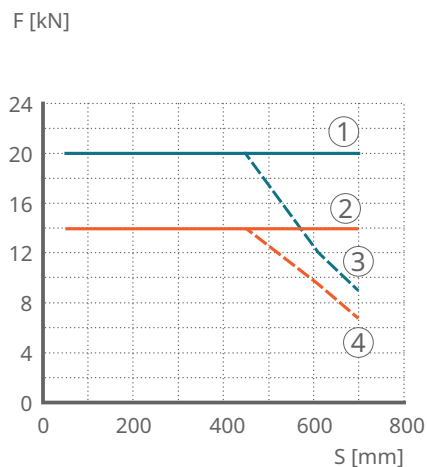

001D178C

1	Ultimate CAHB-21...S (push)	2	Ultimate CAHB-21...S (pull)
3	Recommended CAHB-21...S (push)	4	Recommended CAHB 21...S (pull)
S	Stroke	F	Load

Dimensional drawings

39 Side view dimensions for CAHB-21E, CAHB-21S

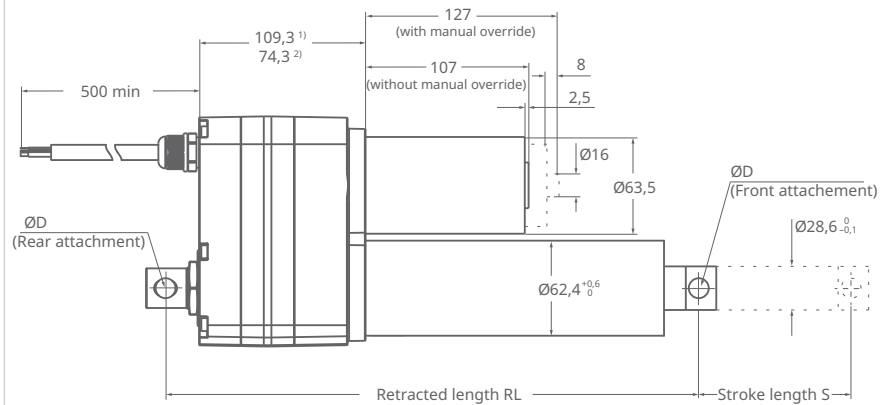

¹⁾ 109,3 for E design with position output

²⁾ 74,3 for E design without position output and S design

001D309B

40 Rear view dimensions for CAHB-21E, CAHB-21S

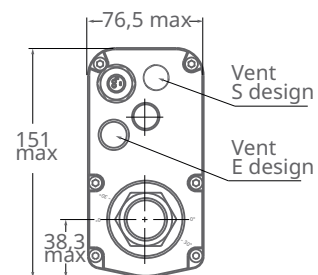

001D308B

22 Tolerances for CAHB-21E and CAHB-21S

Design	Stroke tolerance	Installation length tolerance
	mm	mm
CAHB-21E with LS ($S \leq 305$)	± 2	± 2
CAHB-21E without LS ($S \leq 305$)	$(-2, -0.5)$	± 2
CAHB-21E with LS ($S > 305$)	± 3	± 2
CAHB-21E without LS ($S \leq 305$)	$(-3, -1)$	± 2
CAHB-21S	± 1	± 1

Calculation of the installation length (RL)

23 Calculation of the installation length (RL)

Stroke	Baseline: Rod with hole attachment		Fork head attachment	Anti-rotation tube with free-spinning front attach- ment	Rod end spherical plain bearing with anti-rotation tube	
	50 ... 305	306 ... 700	50 ... 700	50 ... 700	50 ... 305	306 ... 700
	mm	mm	mm	mm	mm	mm
CAHB-21E						
Installation length (RL) with no option ¹²⁾	182+S	217+S	+12	+1	+43	+31
Installation length (RL) with LS	191+S	226+S	+12	+1	+43	+31
Installation length (RL) with position output	217+S	252+S	+12	+1	+43	+31
Installation length (RL) with LS and position out- put ¹³⁾	226+S	261+S	+12	+1	+43	+31
CAHB-21S						
Installation length (RL)	182+S	217+S	+12	+0	+43	+33

¹²⁾ $182 + 50$ (stroke) + 12 (fork head attachment) + 1 (anti-rotation tube with free-spinning front attachment) = 245

¹³⁾ $261 + 400$ (stroke) + 31 (rod end spherical plain bearing with anti-rotation tube) = 692

6 CAHB-22E, CAHB-22S

41 CAHB-22E, CAHB-22S



Benefits

- high productivity
- reliability and safety
- saves development time
- cost effectiveness
- quick time to market (for Smart version)

Characteristics

- high force
- high speed
- high holding force
- mechanical overload protection
- corrosion protection and stainless steel tube
- Manual override option
- higher protection class, practical, maintenance-free

smart version features S

- integrated control system with complete motion control
- true absolute position contactless sensor
- Monitoring and on board diagnostics (force, voltage, temperature)
- I/O and CAN bus SAE J1939 communication

24 Technical information for the CAHB-22E

Characteristic	Unit	CAHB-22E											
		12 V				24 V				48 V			
Rated push force	N	2300	3500	6800	10000	2300	3500	6800	10000	2300	3500	6800	10000
Rated pull force	N	2300	3500	6800	10000	2300	3500	6800	10000	2300	3500	6800	10000
Max pull/push force ¹⁾	N	3500	4900	9500	14000	3500	4900	9500	14000	3500	4900	9500	14000
Holding force ²⁾	N	▶40 ◻46											
Speed without load ³⁾	mm/s	55.0	45.0	22.0	13.0	53.0	45.0	22.0	13.0	57.0	45.0	22.0	13.0
Speed with the rated force ³⁾	mm/s	42.0	36.0	15.5	10.2	42.0	37.0	17.0	10.2	50.0	37.0	18.5	10.2
Rated voltage	V DC	12	12	12	12	24	24	24	24	48	48	48	48
Nominal current at rated load ³⁾	A	18	19.5	19.5	19	8	9.5	9.5	8.5	4.5	5	5	4.3
Nominal current (clutch activation)	A	24.3	25.5	25.5	25	10.6	12.3	12.3	10.9	6.5	7	7	5.5
Duty cycle ⁴⁾	%	10	10	10	10	20	20	20	20	20	20	20	20
ON time/OFF time	s	85/765	85/765	85/765	85/765	85/340	85/340	85/340	85/340	85/340	85/340	85/340	85/340
Stroke S	mm	50 to 700	50 to 700	50 to 610	50 to 450	50 to 700	50 to 700	50 to 610	50 to 450	50 to 700	50 to 700	50 to 610	50 to 450
Backlash	mm	1.0	1.0	0.6	0.6	1.0	1.0	0.6	0.6	1.0	1.0	0.6	0.6
Mass at 200-mm stroke	kg	4.8	4.8	4.8	4.8	4.8	4.8	4.8	4.8	4.8	4.8	4.8	4.8
Color	-	Black	Black	Black	Black	Black	Black	Black	Black	Black	Black	Black	Black
Ambient temperature ⁵⁾	°C	-25 to +85	-25 to +85	-25 to +85	-25 to +85	-25 to +85	-25 to +85	-25 to +85	-25 to +85	-25 to +85	-25 to +85	-25 to +85	-25 to +85
IP protection	-	IP69K, IP66M											
Standards/EMC	-	EN 61000-6-2:2005, EN 61000-6-4:2007/A1:2011											
Salt spray test	-	ISO 9227:2012, 250 h											

¹⁾ Upper limit of the pull/push force limited by the clutch. The lower limiting value is just above the rated force. The limitation of the force will happen between these 2 limits.

²⁾ The holding force is the highest load a powered-down drive can statically hold without slipping backward. For maximum static load, refer to the "Static load" diagrams.

³⁾ The speed and current data in this list is defined at +20 °C.

⁴⁾ Duty cycle: Output force and movement of the linear drive are in the same direction of travel, otherwise the duty cycle is 10 % (25 s ON/225 s OFF).

⁵⁾ Full performance from 0 °C to +40 °C, for use at low temperatures (-40 °C to -25 °C) please contact Schaeffler.

 25 Technical information for the CAHB-22S

Characteristic	Unit	CAHB-22S							
		12 V				24 V ... 48 V			
Rated push force	N	2300	3500	6800	10000	2300	3500	6800	10000
Rated pull force	N	2300	3500	6800	10000	2300	3500	6800	10000
Max pull/push force ⁶⁾	N	3500	4900	9500	14000	3500	4900	9500	14000
Holding force ⁷⁾	N	▶40 ◻47							
Speed without load ⁸⁾	mm/s	55.0	45.0	22.0	13.0	53.0	45.0	22.0	13.0
Speed with the rated force ⁸⁾	mm/s	42.0	36.0	15.5	10.2	42.0	37.0	17.0	10.2
Rated voltage ⁹⁾	V DC	12	12	12	12	24 - 48	24 - 48	24 - 48	24 - 48
Nominal current ⁸⁾	A	18.0	19.5	19.5	19.0	8.0 - 4.0	9.5 - 4.8	9.5 - 4.8	8.5 - 4.3
Max. current, nominal current ¹⁰⁾	A	31.3	31.3	31.3	31.3	20.7 - 10.4	20.7 - 10.4	20.7 - 10.4	20.7 - 10.4
Duty cycle ¹¹⁾	%	10	10	10	10	20	20	20	20
ON time/OFF time	s	85/765	85/765	85/765	85/765	85/340	85/340	85/340	85/340
Stroke S	mm	50 ... 700	50 ... 700	50 ... 610	50 ... 450	50 ... 700	50 ... 700	50 ... 610	50 ... 450
Backlash	mm	1.0	1.0	0.6	0.6	1.0	1.0	0.6	0.6
Max. manual override torque	Nm	1.0	1.0	1.0	1.0	1.0	1.0	1.0	1.0
Max. manual override speed	min ⁻¹	1600	1600	1600	1600	1600	1600	1600	1600
Mass at 200-mm stroke	kg	4.8	4.8	4.8	4.8	4.8	4.8	4.8	4.8
Color	-	Black	Black	Black	Black	Black	Black	Black	Black
Ambient temperature ¹⁰⁾	°C	-25 ... +85	-25 ... +85	-25 ... +85	-25 ... +85	-25 ... +85	-25 ... +85	-25 ... +85	-25 ... +85
IP protection	-	IP69K, IP66M							
Standards/EMC	-	See environmental performances – electrical tests							
Salt spray test	-	ISO 9227:2012, 500 h							

⁶⁾ Upper limit of the pull/push force, limited by the E-clutch.

⁷⁾ The holding force is the highest load a powered-down drive can statically hold without slipping backward. For maximum static load, refer to the "Static load" diagrams.

⁸⁾ The speed and current data in this list is defined at +20 °C, PWM 100 %

⁹⁾ Version for 12 V with DC 12-V motor, version for 24–48 V with DC 24-V motor.

¹⁰⁾ Max. current is the upper limit of the input current to the drive. In any circumstances, the current will not exceed to max. current.

¹¹⁾ The duty cycle is for temperatures of +20 °C and where the direction of the output force of the linear drive is in the same direction of movement as the linear drive, otherwise the duty cycle is 10 % (25 s ON/225 s OFF)

Performance diagrams

6

42 Speed-load diagram for CAHB-22E

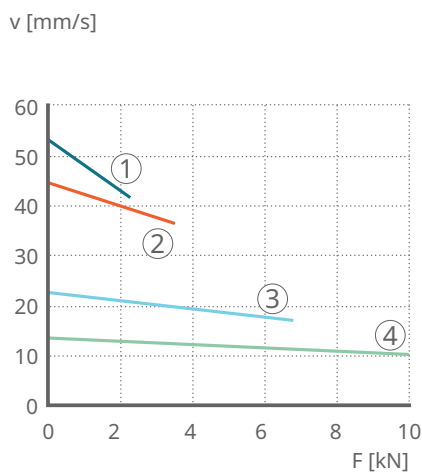

001D178E

1	CAHB-22...1E	2	CAHB-22...2E
3	CAHB-22...3E	4	CAHB-22...4E
F	Load	v	Speed

43 Speed-load diagram for CAHB-22S

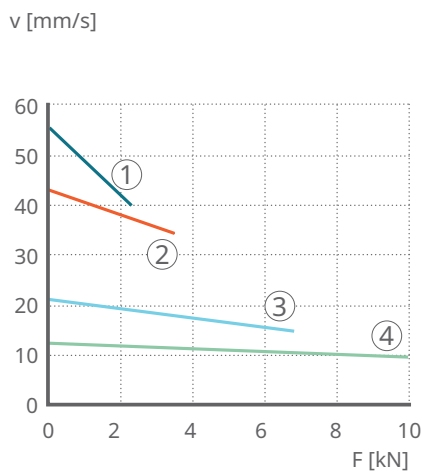

001D1794

1	CAHB-22...1S	2	CAHB-22...2S
3	CAHB-22...3S	4	CAHB-22...4S
F	Load	v	Speed

44 Current-load diagram for CAHB-22E

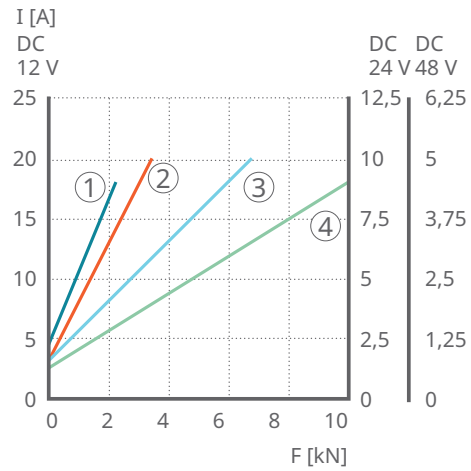

001D178F

1	CAHB-22...1E	2	CAHB-22...2E
3	CAHB-22...3E	4	CAHB-22...4E
F	Load	I	Current consumption

45 Current-load diagram for CAHB-22S

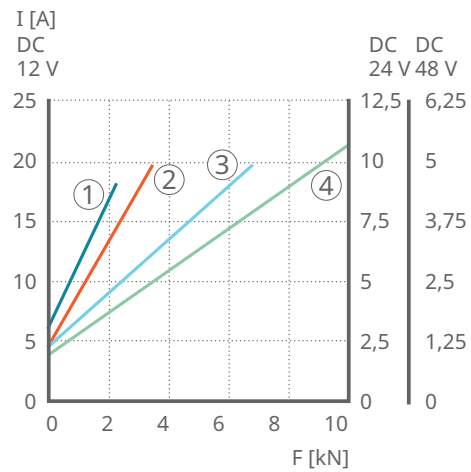

001D1797

1	CAHB-22...1S	2	CAHB-22...2S
3	CAHB-22...3S	4	CAHB-22...4S
F	Load	I	Current consumption

46 Static load stroke length for CAHB-22E

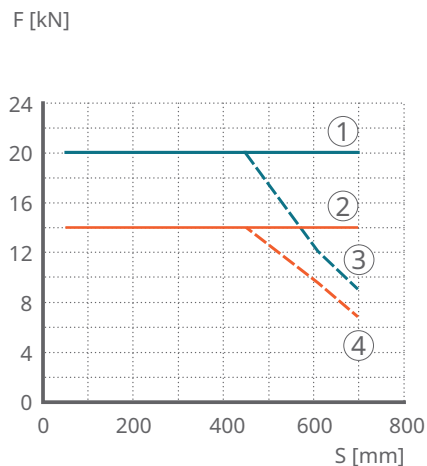

001D179B

1	Ultimate CAHB-22...E (push)	2	Ultimate CAHB-22...E (pull)
3	Recommended CAHB-22...E (push)	4	Recommended CAHB 22...E (pull)
S	Stroke	F	Load

47 Static load stroke length for CAHB-22S

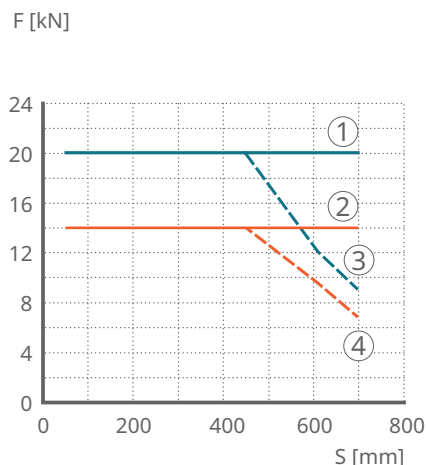

001D179B

1	Ultimate CAHB-22...S (push)	2	Ultimate CAHB-22...S (pull)
3	Recommended CAHB-22...S (push)	4	Recommended CAHB 22...S (pull)
S	Stroke	F	Load

Dimensional drawings

48 Side view dimensions for CAHB-22E, CAHB-22S

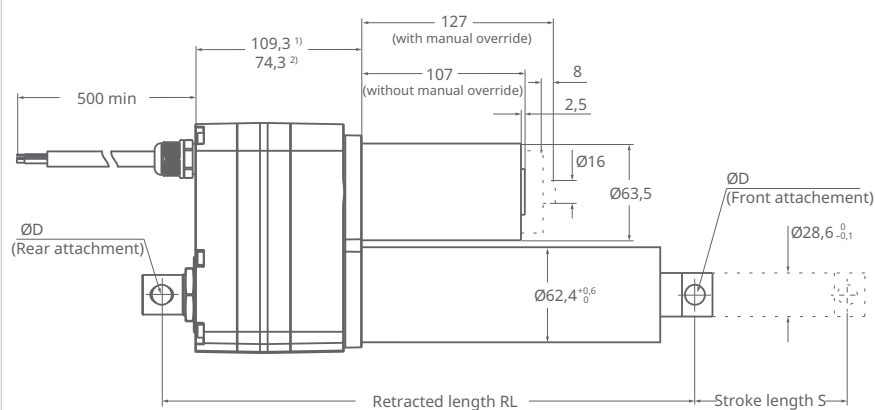

¹⁾ 109,3 for E design with position output

²⁾ 74,3 for E design without position output and S design

001D30BB

49 Rear view dimensions for CAHB-22E, CAHB-22S

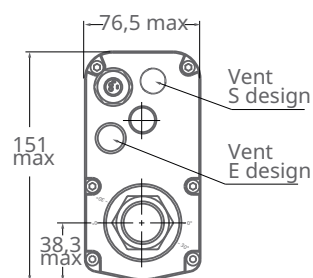

001D30AB

26 Tolerances for CAHB-22E, CAHB-22S

Design	Stroke tolerance	Installation length tolerance
	mm	mm
CAHB-22E with LS ($S \leq 305$)	± 2	(0, +4)
CAHB-22E without LS, 1E/2E ($S \leq 305$)	(-3, -1.5)	(0, +4)
CAHB-22E without LS, 3E/4E ($S \leq 305$)	(-2, -0.5)	(0, +4)
CAHB-22E with LS ($S > 305$)	± 3	(0, +4)
CAHB-22E without LS, 1E/2E ($S > 305$)	(-4, -2)	(0, +4)
CAHB-22E without LS, 3E/4E ($S > 305$)	(-3, -1)	(0, +4)
CAHB-22S	± 1	± 1

Calculation of the installation length (RL)

27 Calculation of the installation length (RL)

Stroke	Baseline: Rod with hole attachment		Fork head attachment	Anti-rotation tube with free-spinning front attach- ment	Rod end spherical plain bearing with anti-rotation tube	
	50 ... 305	306 ... 700	50 ... 700	50 ... 700	50 ... 305	306 ... 700
	mm	mm	mm	mm	mm	mm
CAHB-22E						
Installation length (RL) with no option ¹²⁾	194+S	229+S	+12	+7	+49	+37
Installation length (RL) with LS	200+S	235+S	+12	+7	+49	+37
Installation length (RL) with position output	229+S	264+S	+12	+7	+49	+37
Installation length (RL) with LS and position out- put ¹³⁾	235+S	270+S	+12	+7	+49	+37
CAHB-22S						
Installation length (RL)	200+S	235+S	+12	+0	+43	+33

¹²⁾ $194 + 50$ (stroke) + 12 (fork head attachment) + 7 (anti-rotation tube with free-spinning front attachment) = 263

¹³⁾ $270 + 400$ (stroke) + 37 (rod end spherical plain bearing with anti-rotation tube) = 707

7 Electrical specification for CAHB..E

Power input voltage tolerance

28 Power input voltage tolerance

Power input	Tolerance version
DC 12-V version	DC 10 V...DC 16 V
DC 24-V version	DC 21 V...DC 26 V
DC 48-V version	DC 40 V...DC 55 V

Wire connection without position output

29 Wire connection without position output

Wire no.	AWG	Color	Application
1	14	Red	Motor supply (+) → extension, (-) → retraction
2	14	Black	Motor supply (-) → extension, (+) → retraction

Reference standard for cables: UL758, UL1581 and CSA C22.2 no. 210

Wire connection with position output

50 Potentiometer

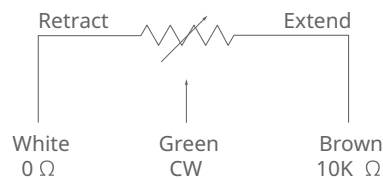

001D30CA

30 Wire connection with potentiometer

Wire no.	AWG	Color	Application
1	22	Green	See picture description
2	22	White	See picture description
3	22	Brown	See picture description
4	14	Red	Motor supply (+) → extension, (-) → retraction
5	14	Black	Motor supply (-) → extension, (+) → retraction

Reference standard for cables: UL758, UL1581 and CSA C22.2 no. 210

51 Extend encoder signal

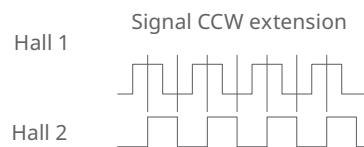

001D30DB

52 Retract encoder signal



001D30EB

31 Wire connection with encoder

Wire no.	AWG	Color	Application
1	26	Green	Sensor signal 1 Encoder
2	26	Yellow	Sensor signal 2 Encoder
3	26	Black	Sensor supply GND Encoder
4	26	Red	5-V sensor supply Encoder
5	14	Red	Motor supply (+) Å extension, (-) Å retraction
6	14	Black	Motor supply (-) Å extension, (+) Å retraction

Reference standard for cables: UL758, UL1581 and CSA C22.2 no. 210

53 Wire connection with absolute analog output

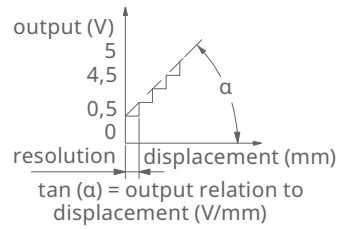

001D30FB

Absolute analog position output

- Input voltage: DC 10 V~DC 55 V
- Current consumption: max. 15 mA
- Analog output signal (voltage): DC 0 V~DC 5 V
- Max. current output: 5 mA

Absolute analog output signal configuration

- Retracted 0.5 ± 0.15 V
- Extended 4.5 V up to maximum

32 Wire connection with absolute analog output

Wire no.	AWG	Color	Application
1	22	Green	Output signal
2	22	White	Sensor supply GND
3	22	Brown	DC +10 V~DC 55 V sensor supply
4	14	Red	Motor supply (+) Å extension, (-) Å retraction
5	14	Black	Motor supply (-) Å extension, (+) Å retraction

Reference standard for cables: UL758, UL1581 and CSA C22.2 no. 210

33 Output relation to travel and resolution

Linear actuator	Hall sensor	Potentiometer (stroke [S])			Absolute analog position output signal (stroke [S])			Resolution of the absolute analog position output signal		
	pulses/mm	Ω /mm			V/mm			mm		
CAHB-20...E	2.76	59.06	if	S = 050 - 125	0.0295	if	S = 050 - 125	0.0413	if	S = 050 - 125
		29.53	if	S = 126 - 250	0.0148	if	S = 126 - 250	0.0827	if	S = 126 - 250
		9.84	if	S = 251 - 700	0.0049	if	S = 251 - 700	0.2480	if	S = 251 - 700
CAHB-21...E	1.56	33.33	if	S = 050 - 222	0.0167	if	S = 050 - 222	0.0732	if	S = 050 - 222
		16.67	if	S = 223 - 444	0.0083	if	S = 223 - 444	0.1465	if	S = 223 - 444
		5.56	if	S = 445 - 700	0.0028	if	S = 445 - 700	0.4395	if	S = 445 - 700
CAHB-22...1E	1.4	30	if	S = 050 - 254	0.0150	if	S = 050 - 254	0.0814	if	S = 050 - 254
CAHB-22...2E	1.4	15	if	S = 255 - 508	0.0075	if	S = 255 - 508	0.1628	if	S = 255 - 508
		5	if	S = 509 - 700	0.0025	if	S = 509 - 700	0.4883	if	S = 509 - 700

Linear actuator	Hall sensor	Potentiometer (stroke [S])			Absolute analog position output signal (stroke [S])			Resolution of the absolute analog position output signal		
	pulses/mm	Ω /mm			V/mm			mm		
CAHB-22...3E	2.8	60	if	S = 050 - 127	0.030	if	S = 050 - 127	0.0407	if	S = 050 - 127
CAHB-22...4E	2.8	30	if	S = 128 - 254	0.015	if	S = 128 - 254	0.0814	if	S = 128 - 254
		10	if	S = 255 - 700	0.005	if	S = 255 - 700	0.2441	if	S = 255 - 700

8 Electrical specification for CAHB..S

CAN bus + I/O

Cable and I/O option 1: code A and code C

- CAHB-20S ▶58 | 76
- CAHB-21S ▶62 | 80
- CAHB-22S ▶66 | 84

34 CAN bus + I/O

Wire no.	AWG	Color	Application
1	14	Red	Connect VCC supply (+) to positive DC 9 V ... DC 16 V (12-V version) DC 18 V ... DC 55 V (24 – 48-V version)
2	14	Black	Supply (-) GND Connect to negative
3	26	Red	Extension command input High level: DC 5 V ... DC 55 V Low level: DC 0 V ... DC 1.19 V Max. current consumption: 1 mA Delay before movement and stop: 50 ms
4	26	Black	Retraction command input High level: DC 5 V ... DC 55 V Low level: DC 0 V ... DC 1.19 V Max. current consumption: 1 mA Delay before movement and stop: 50 ms
5	26	Yellow	CAN H (CAN bus J1939)
6	26	Blue	CAN L (CAN bus J1939)
7	26	Gray	End stop signal (Digital output, open collector) Normal (L): hi-Z Extended (H): V supply – 1.8 V. Max. current consumption: 10 mA
8	26	Orange	End stop signal (Digital output, open collector) Normal (L): hi-Z Retracted (H): V supply – 1.8 V. Max. current consumption: 10 mA
13	26	Green	Analog position signal output Retracted position: 0.5 ± 0.02 V Extended position: 5 V/10 V (standard) Max. current output: 15 mA Max. ripple: 200 mV Transaction delay: 20 ms Linear feedback 0.5 % $\tan(\alpha)=4.5/\text{stroke (V/mm)}$, code A or $9.5/\text{stroke (V/mm)}$, code C Resolution: $10 \text{ V}/4000/\tan(\alpha)$
14	26	White	Analog position sensor supply (-) GND Common ground with core no. 2
15	26	Brown	Analog position sensor supply (+) For position sensor output $0 \text{ V} \sim 5 \text{ V}^{1)}$: DC 8 V ... DC 27 V For position sensor output $0 \text{ V} \sim 10 \text{ V}^{1)}$: DC 13 V ... DC 27 V Max. current consumption: 15 mA
16	26	Purple	Reserved, not to be connected

¹⁾ Position sensor output selected via the order designation

Reference standard for cables: UL758, UL1581 and CSA C22.2 no. 210

54 CAN BUS + I/O output

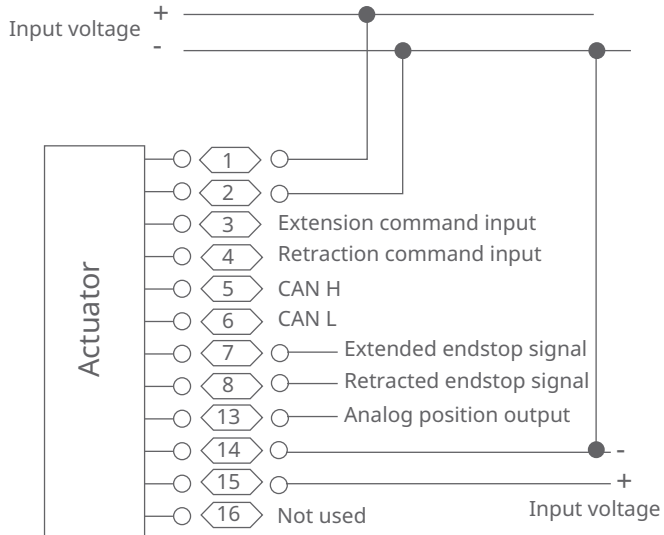

001D310B

55 CAN BUS+ I/O output signal

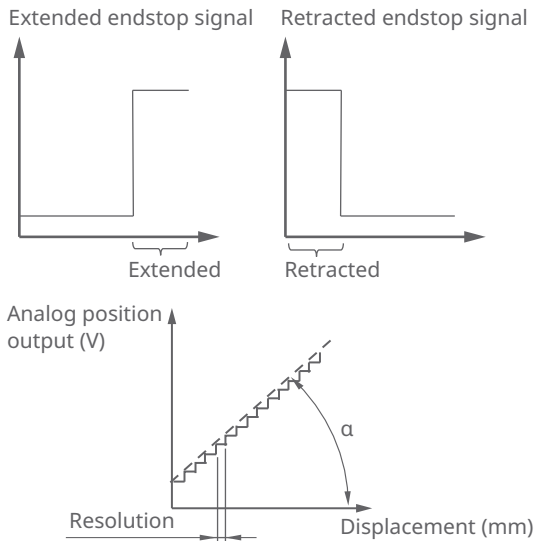

001D311B

CAN bus + Input

Cable and I/O option 1: code B

- CAHB-20S ▶58 | 76
- CAHB-21S ▶62 | 80
- CAHB-22S ▶66 | 84

35 CAN bus + Input

Wire no.	AWG	Color	Application
1	14	Red	Connect VCC supply (+) to positive DC 9 V ... DC 16 V (12-V version) DC 18 V ... DC 55 V (24 - 48-V version)
2	14	Black	Supply (-) GND Connect to negative
3	26	Red	Extension command input High level: DC 5 V ... DC 55 V Low level: DC 0 V ... DC 1.19 V Max. current consumption: 1 mA Delay before movement and stop: 50 ms
4	26	Black	Retraction command input High level: DC 5 V ... DC 55 V Low level: DC 0 V ... DC 1.19 V Max. current consumption: 1 mA Delay before movement and stop: 50 ms
5	26	Yellow	CAN H (CAN bus J1939)
6	26	Blue	CAN L (CAN bus J1939)

Reference standard for cables: UL758, UL1581 and CSA C22.2 no. 210

56 CAN bus + Input

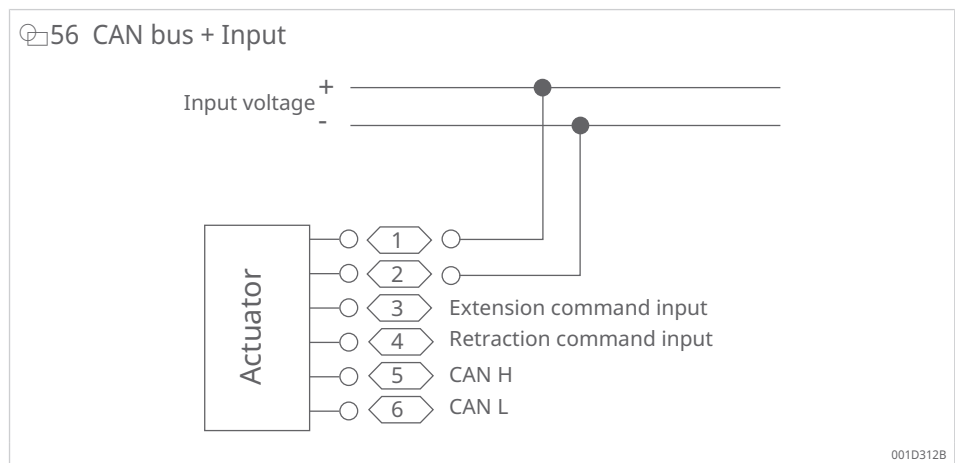

Termination resistance option

Bus type option 2

- CAHB-20S ▶58 | 76
- CAHB-21S ▶62 | 80
- CAHB-22S ▶66 | 84

57 Without termination resistor (code C)

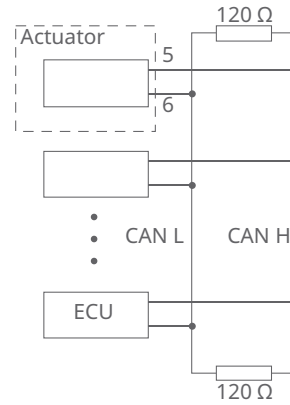

001D313B

8

58 With termination resistor (code T)

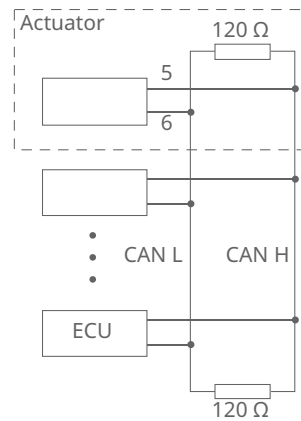

001D314B

The vehicle CAN bus system requires a termination resistor. The CAHB 2xS could be equipped one.

9 Attachment options for CAHB..E and CAHB..S

Attachment type: rod end with hole (according to order overview, attachment diameter A – E)

59 Rear attachment

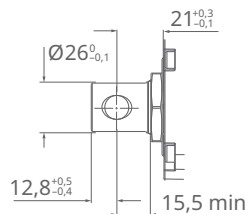

001CF046

60 Front attachment without anti-rotation tube

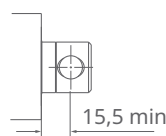

Attachment orientation: "A" to "F"

001D315B

61 Front attachment with anti-rotation tube

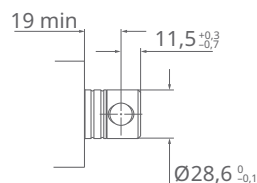

Attachment orientation: "G" to "L"

001D316B

62 Anti-rotation tube rod end

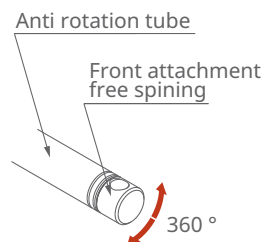

001D3179

36 Rod end with bore

Hole version	A	B	C	D	E
	mm	mm	mm	mm	mm
Hole diameter Ø	13.1	12.8	12.5	14	12.2
Tolerance	H11	H11	H11	H11	H11

Attachment type: fork head with hole (according to order overview, attachment diameter F – G)

63 Rear attachment

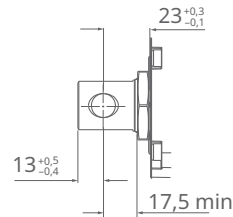

001CF047

64 Rear attachment

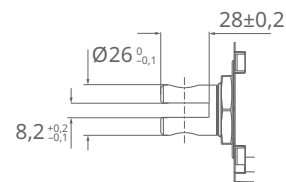

001CF04F

65 Front attachment without anti-rotation tube

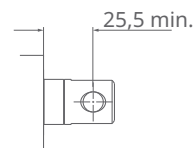

001CF048

66 Front attachment without anti-rotation tube

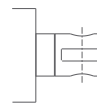

Attachment orientation: "A" to "F"

001D319B

67 Front attachment with anti-rotation tube

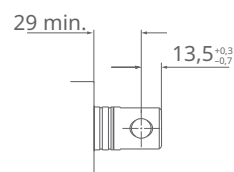

001CF04C

68 Front attachment with anti-rotation tube

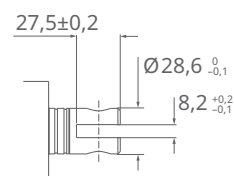

Attachment orientation: "G" to "L"

001D31AA

69 Fork head anti-rotation tube

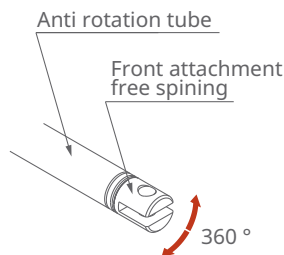

001D318A

37 Fork head with hole

Hole version	F	G
	mm	mm
Hole diameter Ø	12.2	12.8
Tolerance	H11	H11

Attachment type: rod end spherical plain bearing (attachment diameter I as per order overview)

70 Rear attachment

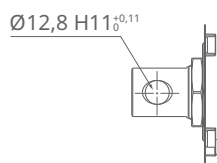

"I" and "B" have the same rear attachment

001D31B8

71 Front attachment with anti-rotation tube

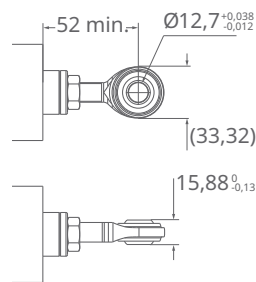

Attachment orientation: "G" to "L"

001D31CB

38 Rod end spherical plain bearing

Hole version	I (Rear Attachment)	I (front Attachment)
	mm	mm
Hole diameter Ø	12.8	12.7

Attachment orientation (see order designation "Attachment orientation")

72 Attachment orientation

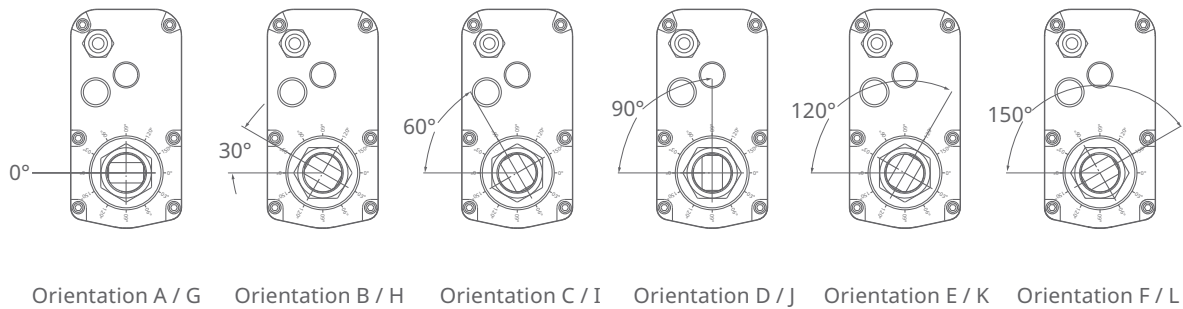

001D31DB

9

39 Attachment orientation

Attachment orientation	Designation	
A	0°	without anti-rotation tube
B	30°	without anti-rotation tube
C	60°	without anti-rotation tube
D	90°	without anti-rotation tube
E	120°	without anti-rotation tube
F	150°	without anti-rotation tube
G	0°	with anti-rotation tube and free-spinning front attachment
H	30°	with anti-rotation tube and free-spinning front attachment
I	60°	with anti-rotation tube and free-spinning front attachment
J	90°	with anti-rotation tube and free-spinning front attachment
K	120°	with anti-rotation tube and free-spinning front attachment
L	150°	with anti-rotation tube and free-spinning front attachment

Manual operation

Release the motor cover (1). Use the slot (2) to rotate the motor shaft (3) in the right direction.

73 Manual operation

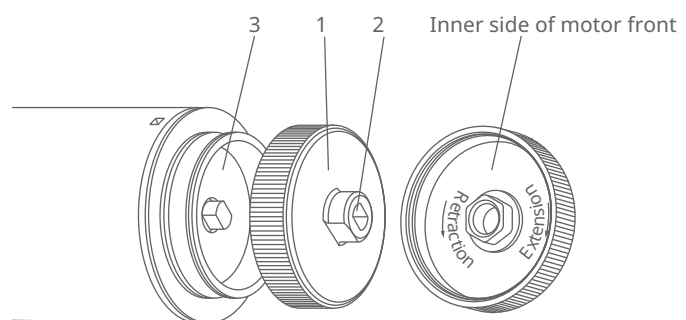

001D31EB

1	Motor cover	2	Slot
3	Motor shaft		

10 Functional overview of CAHB..S

40 Functional overview of CAHB-20S, CAHB-21S, CAHB-22S

		CAHB-2...S only	CAN bus + I/O Order code Option 1, code A or C	CAN bus + Input Order code Option 1, code B	
Interface	Voltage version	DC 12 V	✓	✓	
		DC 24 V...DC 48 V	✓	✓	
	Cable	n° supply of cores	2	2	
		n° low-current cores	10	4	
BUS	CAN bus SAE J1939, 250 or 500 Kbit/s ¹⁾	✓	✓		
Functions	Movement	Soft start/soft stop	✓	✓	
	E clutch	Force limitation (calibration, temperature compensation)	✓	✓	
	Adjustable end stops	Adjustable retracted and extended length via I/O and CAN bus	-	-	
	Parallel motion	Linear drive with the same length up to	2 pcs.	2 pcs.	
Command	Command I/O	Motion Extend / Retract	✓	✓	
	CAN bus J1939	Motion Extend / Retract	✓	✓	
		Movement relative to drive length in 1/10-mm increments	✓	✓	
		Speed, command set in %	✓	✓	
		Max. force, command set in N	✓	✓	
Real-time feedback	I/O signal end stop	End stop extended	✓	-	
		End stop retracted	✓	-	
	Position feedback by I/O	0 V ... 10 V or 0 V ... 5 V, absolute, analog	✓	-	
	CAN bus J1939 feedback	Drive length in 1/10 mm increments	✓	✓	
		Force in N	✓	✓	
		Speed in %	✓	✓	
		Flag for end stop retracted	✓	✓	
		Flag for end stop extended	✓	✓	
		Flag for operation during retraction	✓	✓	
	Diagnostics by CAN bus (on-board)	Application monitoring	Voltage, upper limit reached	✓	✓
			Temperature, upper limit reached	✓	✓
			Force, upper limit reached	✓	✓
			Linear drive blocked	✓	✓
	Integrity monitoring	Error Code	✓	✓	
Regulations and testing	Compliance	CE marking, Declaration of Incorporation for partly completed machinery: RoHS, EMV + REACH	✓	✓	
	Environmental tests	Mechanics	Extended	Extended	
		Climate	Extended	Extended	
		Electrical system	Extended	Extended	
		Load dump protection, chassis connected to negative terminal	✓	✓	
		Load dump protection, housing not connected	✓	✓	
		Reinforced load dump protection ²⁾ , housing connected to negative terminal	Option for DC 12 V	Option for DC 12 V	
		Reinforced load dump protection ²⁾ , housing not connected	Option for DC 12 V	Option for DC 12 V	

✓ available

- 1) The baud rate is 250 Kbit/s by default. To change the CAN baud rate for the CAN message, the control unit ECU used for the setting must support both 500 Kbit/s and 250 Kbit/s.
- 2) For vehicles without centralized load dump protection

Ordering key

74 CAHB-20E order designation, part 1

CAHB - 20 A 1 E - 050 0210 - B A A - B A A 0 0 T - 000

Type

Voltage

- A DC 12 V
- B DC 24 V
- D DC 48 V
- E DC 12 V with manual operation
- F DC 24 V with manual operation
- H DC 48 V with manual operation

Load

- 1 1500 N
- 2 2500 N

Design

E

3 × digital stroke length and 3 × digital retracted length (mm)

Stroke	Retracted length basic conf. ¹⁾	with rod clevis F, G	With spherical plain bearing ²⁾ I	With anti-rotation device G to L	With position output A, P, E
050	0210	+12	+42	5	+35
100	0260	+12	+42	5	+35
150	0310	+12	+42	5	+35
200	0360	+12	+42	5	+35
250	0410	+12	+42	5	+35
300	0460	+12	+42	5	+35
350	0561	+12	+30	-11	+35
400	0611	+12	+30	-11	+35
450	0661	+12	+30	-11	+35
500	0711	+12	+30	-11	+35
600	0811	+12	+30	-11	+35
700	0911	+12	+30	-11	+35

Degree of protection

B Standard: IP69K/IP66M and equipped with a vent, built-in thermal protection, protection clutch and EMC filter

Attachment diameter (Front and rear)

- A Rod end with hole Ø 13.1 mm
- B Rod end with hole Ø 12.8 mm
- C Rod end with hole Ø 12.5 mm
- D Rod end with hole Ø 14 mm
- E Rod end with hole Ø 12.2 mm
- F Fork head with hole Ø 12.2 mm and slot 8.2 mm
- G Fork head with hole Ø 12.8 mm and slot 8.2 mm
- I Rod end spherical plain bearing Ø 12.7 mm, rear end with hole Ø 12.8 mm (requires anti-rotation tube option)
- X Customization

Attachment orientation (Front and rear)

- A 0° without anti rotation tube
- B 30° without anti rotation tube
- C 60° without anti rotation tube
- D 90° without anti rotation tube
- E 120° without anti rotation tube
- F 150° without anti rotation tube
- G 0°: with anti rotation tube and free spinning front attachment
- H 30° with anti rotation tube and free spinning front attachment
- I 60° with anti rotation tube and free spinning front attachment
- J 90° with anti rotation tube and free spinning front attachment
- K 120° with anti rotation tube and free spinning front attachment
- L 150° with anti rotation tube and free spinning front attachment
- X Customization

001E01D5

10

75 CAHB-20E order designation, part 2

CAHB - 20 A 1 E - 050 0210 - B A A - B A A 0 0 T - 000

Option 1: limit switch

0 Not available

Option 2: position output

0 No option
 A Absolute analog output signal
 P Potentiometer
 E Encoder

Thermal protection

T Standard integrated thermal switch

Customization

Stroke length, retracted length, cable, connector, front attachment, rear attachment, color, de-rated load

¹⁾ Basic configuration: the retracted length with "rod end with hole" attachment, without "anti-rotation tube", without "position output"

²⁾ For "spherical bearing" attachment, the "anti-rotation tube" option is mandatory. To calculate the retracted length, the length "with anti-rotation device" must be added.

001E01F5

Standard linear drives are IP protection class IP69K/IP66M and are equipped a vent, built-in thermal protection, protection clutch and EMC filter.

76 CAHB-20S order designation, part 1

CAHB - 20 A 1 S - 050 0217 - 1 A G A C T - 000

Type

Voltage

- A DC 12 V
- B DC 24-48 V
- E DC 12 V with manual operation
- F DC 24-48 V with manual operation

Load

- 1 1500 N
- 2 2500 N
- 3 4500 N

Design

S

Stroke

Stroke	Retracted length basic conf. ¹⁾	With fork head F, G	With Spherical plain bearing I
050	0217	+12	+43
100	0267	+12	+43
150	0317	+12	+43
200	0367	+12	+43
250	0417	+12	+43
300	0467	+12	+43
350	0552	+12	+33
400	0602	+12	+33
450	0652	+12	+33
500	0702	+12	+33
600	0802	+12	+33
700	0902	+12	+33

Parallel operation self-controlled

- 1 1 linear drive is operated independently
- 2 Two line actuators are operated simultaneously in parallel mode

Attachment diameter (Front and rear)

- A Rod end with hole Ø 13.1 mm
- B Rod end with hole Ø 12.8 mm
- C Rod end with hole Ø 12.5 mm
- D Rod end with hole Ø 14 mm
- E Rod end with hole Ø 12.2 mm
- F Fork head with hole Ø 12.2 mm and slot 8.2 mm
- G Fork head with hole Ø 12.8 mm and slot 8.2 mm
- I Rod end spherical plain bearing Ø 12.7 mm, rear end with hole Ø 12.8 mm
- X Customization

Attachment orientation (Front and rear)

- G 0°: with anti rotation tube and free spinning front attachment
- H 30° with anti rotation tube and free spinning front attachment
- I 60° with anti rotation tube and free spinning front attachment
- J 90° with anti rotation tube and free spinning front attachment
- K 120° with anti rotation tube and free spinning front attachment
- L 150° with anti rotation tube and free spinning front attachment
- X Customization

Option 1: wiring and I/O variants

- A Analog I/O (bus, 2 x command inputs, 2 x end stop outputs, absolute analog position output signal 0-10 V)
- C Analog I/O (bus, 2 x command inputs, 2 x end stop outputs, absolute analog position output signal 0-5 V)
- B Bus (Bus, 2 command input)

Option 2: bus type

- C Standard CAN without termination resistor
- T CAN with termination resistor

001E01E5

10

77 CAHB-20S order designation, part 2

CAHB - 20 A 1 S - 050 0217 - 1 A G A C T - 000

Protection

T	Standard chassis connected to negative terminal, built-in thermal protection
U	Chassis connected to negative terminal, reinforced load dump protection ²⁾ , built-in thermal protection
V	Chassis not connected, Built-in thermal protection
W	Chassis not connected, reinforced load dump protection ²⁾ , built-in thermal protection

Customization

Stroke length, retracted length, cable, connector, front attachment, rear attachment, color, de-rated load

¹⁾ Basic configuration: the retracted length with "rod end with hole" attachment

²⁾ For vehicles without centralized load dump protection, the option only applies to 12 V

001E0205

78 CAHB-21E order designation, part 1

CAHB - 21 A 1 E - 050 0232 - B A A 0 0 T - 000

Type

Voltage

- A DC 12 V
- B DC 24 V
- D DC 48 V
- E DC 12 V with manual operation
- F DC 24 V with manual operation
- H DC 48 V with manual operation

Load

- 1 1500 N
- 2 2500 N
- 3 4500 N

Design

E

3 × digital stroke length and 4 × digital retracted length (mm)

Stroke	Retracted length basic conf. ¹⁾	With fork head F, G	With spherical plain bearing ²⁾ I	With anti-rotation device G to L	With limit switch L	With position output A, P, E
050	0232	+12	+42	1	+9	+35
100	0282	+12	+42	1	+9	+35
150	0332	+12	+42	1	+9	+35
200	0382	+12	+42	1	+9	+35
250	0432	+12	+42	1	+9	+35
300	0482	+12	+42	1	+9	+35
350	0567	+12	+30	1	+9	+35
400	0617	+12	+30	1	+9	+35
450	0667	+12	+30	1	+9	+35
500	0717	+12	+30	1	+9	+35
600	0817	+12	+30	1	+9	+35
700	0917	+12	+30	1	+9	+35

Degree of protection

B Standard: IP69K/IP66M and equipped with a vent, built-in thermal protection, protection clutch and EMC filter

Attachment diameter (Front and rear)

- A Rod end with hole Ø 13.1 mm
- B Rod end with hole Ø 12.8 mm
- C Rod end with hole Ø 12.5 mm
- D Rod end with hole Ø 14 mm
- E Rod end with hole Ø 12.2 mm
- F Fork head with hole Ø 12.2 mm and slot 8.2 mm
- G Fork head with hole Ø 12.8 mm and slot 8.2 mm
- I Rod end spherical plain bearing Ø 12.7 mm, rear end with hole Ø 12.8 mm (requires anti-rotation tube option)

X Customization

Attachment orientation (Front and rear)

- A 0° without anti rotation tube
- B 30° without anti rotation tube
- C 60° without anti rotation tube
- D 90° without anti rotation tube
- E 120° without anti rotation tube
- F 150° without anti rotation tube
- G 0° with anti rotation tube and free spinning front attachment
- H 30° with anti rotation tube and free spinning front attachment
- I 60° with anti rotation tube and free spinning front attachment
- J 90° with anti rotation tube and free spinning front attachment
- K 120° with anti rotation tube and free spinning front attachment
- L 150° with anti rotation tube and free spinning front attachment
- X Customization

001E0215

10

79 CAHB-21E order designation, part 2

CAHB - 21 A 1 E - 050 0232 - B A A 0 0 T - 000

Option 1: limit switch

- 0 None (mandatory for version with 1500 N, 2500 N and version with DC 48 V)
- L Limit switch (valid only for load version 4500 at DC 12 or 24 V)

Option 2: position output

- 0 No option
- A Absolute analog output signal
- P Potentiometer
- E Encoder

Thermal protection

- T Standard integrated thermal switch

Customization

Stroke length, retracted length, cable, connector, front attachment, rear attachment, color, de-rated load

¹⁾ Basic configuration: the retracted length with "rod end with hole" attachment, without "anti-rotation tube", without "position output"

²⁾ For "spherical bearing" attachment, the "anti-rotation tube" option is mandatory. To calculate the retracted length, the length "with anti-rotation device" must be added.

001E0225

10

Standard linear drives are IP protection class IP69K/IP66M and are equipped a vent, built-in thermal protection, protection clutch and EMC filter.

80 CAHB-21S order designation, part 1

CAHB - 21 A 1 S - 050 0232 - 1 A G A C T - 000

Type

Voltage

- A DC 12 V
- B DC 24-48 V
- E DC 12 V with manual operation
- F DC 24-48 V with manual operation

Load

- 1 1500 N
- 2 2500 N
- 3 4500 N

Design

S

3 × digital stroke length and 4 × digital retracted length (mm)

Stroke	Retracted length basic conf. ¹⁾	With fork head F, G	With Spherical plain bearing I
050	0232	+12	+43
100	0282	+12	+43
150	0332	+12	+43
200	0382	+12	+43
250	0432	+12	+43
300	0482	+12	+43
350	0567	+12	+33
400	0617	+12	+33
450	0667	+12	+33
500	0717	+12	+33
600	0817	+12	+33
700	0917	+12	+33

Parallel operation self-controlled

- 1 1 linear drive is operated independently
- 2 Two line actuators are operated simultaneously in parallel mode

Attachment diameter (Front and rear)

- A Rod end with hole Ø 13.1 mm
- B Rod end with hole Ø 12.8 mm
- C Rod end with hole Ø 12.5 mm
- D Rod end with hole Ø 14 mm
- E Rod end with hole Ø 12.2 mm
- F Fork head with hole Ø 12.2 mm and slot 8.2 mm
- G Fork head with hole Ø 12.8 mm and slot 8.2 mm
- I Rod end spherical plain bearing Ø 12.7 mm, rear end with hole Ø 12.8 mm
- X Customization

Attachment orientation (Front and rear)

- G 0° with anti rotation tube and free spinning front attachment
- H 30° with anti rotation tube and free spinning front attachment
- I 60° with anti rotation tube and free spinning front attachment
- J 90° with anti rotation tube and free spinning front attachment
- K 120° with anti rotation tube and free spinning front attachment
- L 150° with anti rotation tube and free spinning front attachment
- X Customization

Option 1: wiring and I/O variants

- A Analog I/O (bus, 2 x command inputs, 2 x end stop outputs, absolute analog position output signal 0-10 V)
- C Analog I/O (bus, 2 x command inputs, 2 x end stop outputs, absolute analog position output signal 0-5 V)
- B Bus (Bus, 2 command input)

Option 2: bus type

- C Standard CAN without termination resistor
- T CAN with termination resistor

001E0235

10

81 CAHB-21S order designation, part 2

CAHB - 21 A 1 S - 050 0232 - 1 A G A C T - 000

Protection

T	Standard chassis connected to negative terminal, built-in thermal protection
U	Chassis connected to negative terminal, reinforced load dump protection ²⁾ , built-in thermal protection
V	Chassis not connected, Built-in thermal protection
W	Chassis not connected, reinforced load dump protection ²⁾ , built-in thermal protection

Customization

Stroke length, retracted length, cable, connector, front attachment, rear attachment, color, de-rated load

¹⁾ Basic configuration: the retracted length with "rod end with hole" attachment

²⁾ For vehicles without centralized load dump protection, the option only applies to 12 V

001E0245

82 CAHB-22E order designation, part 1

CAHB - 22 A 1 E - 050 0244 - B A A 0 0 T - 000

Type

Voltage

- A DC 12 V
- B DC 24 V
- D DC 48 V
- E DC 12 V with manual operation
- F DC 24 V with manual operation
- H DC 48 V with manual operation

Load

- 1 2300 N
- 2 3500 N
- 3 6800 N
- 4 10000 N

Design

E

3 × digital stroke length and 4 × digital retracted length (mm)

Stroke	Retracted length basic conf. ¹⁾	With fork head F, G	With spherical plain bearing ²⁾ I	With anti-rotation device G to L	With limit switch L	With position output A, P, E
050	0244	+12	+42	+7	6	+35
100	0294	+12	+42	+7	6	+35
150	0344	+12	+42	+7	6	+35
200	0394	+12	+42	+7	6	+35
250	0444	+12	+42	+7	6	+35
300	0494	+12	+42	+7	6	+35
350	0579	+12	+30	+7	6	+35
400	0629	+12	+30	+7	6	+35
450	0679	+12	+30	+7	6	+35
500	0729	+12	+30	+7	6	+35
600	0829	+12	+30	+7	6	+35
700	0929	+12	+30	+7	6	+35

Degree of protection

- B Standard: IP69K/IP66M and equipped with a vent, built-in thermal protection, protection clutch and EMC filter

Attachment diameter (Front and rear)

- A Rod end with hole Ø 13.1 mm
- B Rod end with hole Ø 12.8 mm
- C Rod end with hole Ø 12.5 mm
- D Rod end with hole Ø 14 mm
- E Rod end with hole Ø 12.2 mm
- F Fork head with hole Ø 12.2 mm and slot 8.2 mm
- G Fork head with hole Ø 12.8 mm and slot 8.2 mm
- I Rod end spherical plain bearing Ø 12.7 mm, rear end with hole Ø 12.8 mm (requires anti-rotation tube option)
- X Customization

001E0255

10

83 CAHB-22E order designation, part 2

CAHB - 22 A 1 E - 050 0244 - B A A 0 0 T - 000

Attachment orientation (Front and rear)

A	0° without anti rotation tube
B	30° without anti rotation tube
C	60° without anti rotation tube
D	90° without anti rotation tube
E	120° without anti rotation tube
F	150° without anti rotation tube
G	0°: with anti rotation tube and free spinning front attachment
H	30° with anti rotation tube and free spinning front attachment
I	60° with anti rotation tube and free spinning front attachment
J	90° with anti rotation tube and free spinning front attachment
K	120° with anti rotation tube and free spinning front attachment
L	150° with anti rotation tube and free spinning front attachment
X	Customization

Option 1: limit switch

0	None (mandatory for version with 2300 N, 3500 N and version with DC 48 V)
L	Limit switch (valid for load version 6 800 N and 10 000 N)

Option 2: position output

0	No option
A	Absolute analog output signal
P	Potentiometer
E	Encoder

Thermal protection

T	Standard integrated thermal switch
---	------------------------------------

Customization

Stroke length, retracted length, cable, connector, front attachment, rear attachment, color, de-rated load

¹⁾ Basic configuration: the retracted length with "rod end with hole" attachment, without "anti-rotation tube", without "position output"

²⁾ For "spherical bearing" attachment, the "anti-rotation tube" option is mandatory. To calculate the retracted length, the length "with anti-rotation device" must be added.

001E0265

Standard linear drives are IP protection class IP69K/IP66M and are equipped a vent, built-in thermal protection, protection clutch and EMC filter.

84 CAHB-22S order designation, part 1

CAHB - 22 A 1 S - 050 0250 - 1 A G A C T - 000

Type

Voltage

- A DC 12 V
- B DC 24-48 V
- E DC 12 V with manual operation
- F DC 24-48 V with manual operation

Load

- 1 2300 N
- 2 3500 N
- 3 6800 N
- 4 10000 N

Design

S

3 × digital stroke length and 4 × digital retracted length (mm)

Stroke	Retracted length basic conf. ¹⁾	With fork head F, G	With Spherical plain bearing
050	0250	+12	+43
100	0300	+12	+43
150	0350	+12	+43
200	0400	+12	+43
250	0450	+12	+43
300	0500	+12	+43
350	0585	+12	+33
400	0635	+12	+33
450	0685	+12	+33
500	0735	+12	+33
600	0835	+12	+33
700	0935	+12	+33

Parallel operation self-controlled

- 1 1 linear drive is operated independently
- 2 Two line actuators are operated simultaneously in parallel mode

Attachment diameter (Front and rear)

- A Rod end with hole Ø 13.1 mm
- B Rod end with hole Ø 12.8 mm
- C Rod end with hole Ø 12.5 mm
- D Rod end with hole Ø 14 mm
- E Rod end with hole Ø 12.2 mm
- F Fork head with hole Ø 12.2 mm and slot 8.2 mm
- G Fork head with hole Ø 12.8 mm and slot 8.2 mm
- I Rod end spherical plain bearing Ø 12.7 mm, rear end with hole Ø 12.8 mm
- X Customization

Attachment orientation (Front and rear)

- G 0° (Standard) with Free spinning
- H 30° with Free spinning
- I 60° with Free spinning
- J 90° with Free spinning
- K 120° with Free spinning
- L 150° with Free spinning

Option 1: wiring and I/O variants

- A Analog I/O (bus, 2 x command inputs, 2 x end stop outputs, absolute analog position output signal 0-10 V)
- C Analog I/O (bus, 2 x command inputs, 2 x end stop outputs, absolute analog position output signal 0-5 V)
- B Bus (Bus, 2 command input)

Option 2: bus type

- C Standard CAN without termination resistor
- T CAN with termination resistor

10

85 CAHB-22S order designation, part 2

CAHB - 22 A 1 S - 050 0250 - 1 A G A C T - 000

Protection

T	Standard chassis connected to negative terminal, built-in thermal protection
U	Chassis connected to negative terminal, reinforced load dump protection ²⁾ , built-in thermal protection
V	Chassis not connected, Built-in thermal protection
W	Chassis not connected, reinforced load dump protection, built-in thermal protection

Customization

Stroke length, retracted length, cable, connector, front attachment, rear attachment, color, de-rated load

¹⁾ Basic configuration: the retracted length with "rod end with hole" attachment

²⁾ For vehicles without centralized load dump protection, the option only applies to 12 V.

001E0285

11 CAHB-30A

86 CAHB-30A



Benefits

- powered by AC voltage
- designed and tested for harsh environments
- reliable and cost-effective
- reduced development and startup times
- virtually maintenance-free

Characteristics

- optional potentiometer and limit switches
- self-locking
- integrated thermal and overload protection
- robust design, IP65S, wide temperature range, corrosion resistant

41 Technical information for the CAHB-30A

Characteristic		Unit	CAHB-30A...1	CAHB-30A...2
Rated push force		N	1500	2300
Rated pull force		N	1500	2300
Holding force ¹⁾		N	10000	10000
Speed (full load ... no load)	AC 115 V/60 Hz	mm/s	25 to 26	12 to 13
	AC 230 V/50 Hz	mm/s	21 to 22	11 to 12
Stroke S		mm	102 to 610	102 to 610
Voltage		V AC	115 / 230	115 / 230
Nominal current	AC 115 V/60 Hz	A	2.3	1.8
	AC 230 V/50 Hz	A	1.35	1.4
Duty cycle of operation		%	25	25
ON time / OFF time		s	94 / 376	94 / 376
Ambient temperature		°C	-26 to +65	-26 to +65
IP protection		-	IP65S	IP65S
Mass		kg	9	9
Color		-	Black	Black

¹⁾ The holding force is the highest load a powered-down drive can statically hold without slipping backward.

Basic configuration (dashed line for optional limit switch)

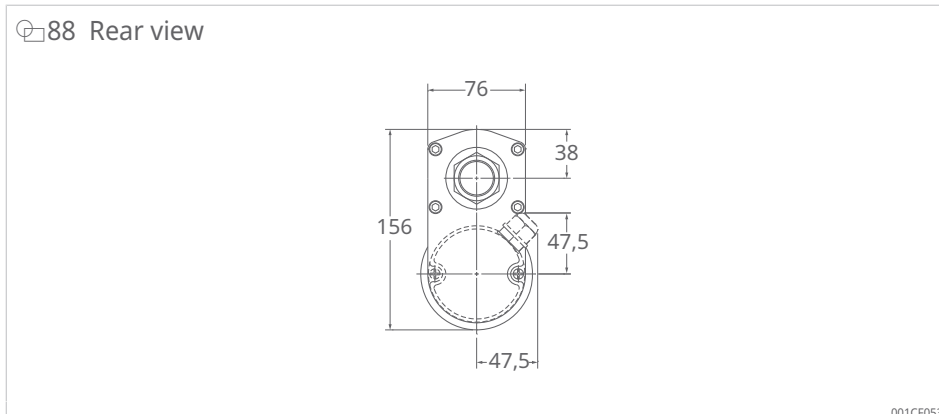
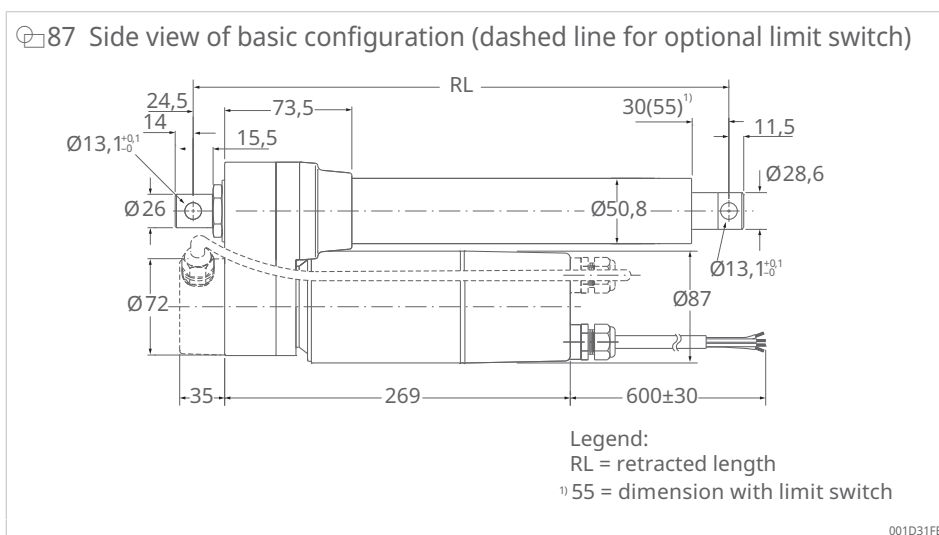

42 Calculation of the installation length (RL): basic configuration

Stroke	Unit	With limit switch ²⁾						Without limit switch ³⁾					
		102	153	204	305	457	610	102	153	204	305	457	610
Installation length (RL)	mm	440	440	440	592	744	897	380	415	415	465	668	821

²⁾ Tolerance: S and RL = ±5.0 mm (if S ≥ 305 mm, S = ±7.5 mm)

³⁾ Tolerance: S = ±2.5 mm and L = ±3.8 mm

Optional potentiometer (dashed line for optional limit switch)

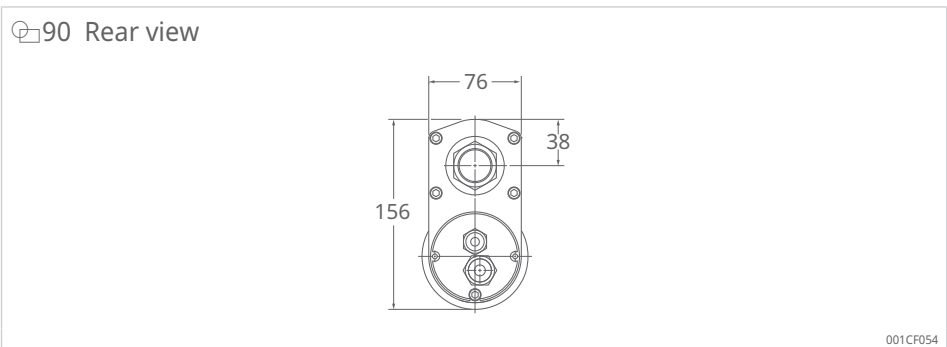
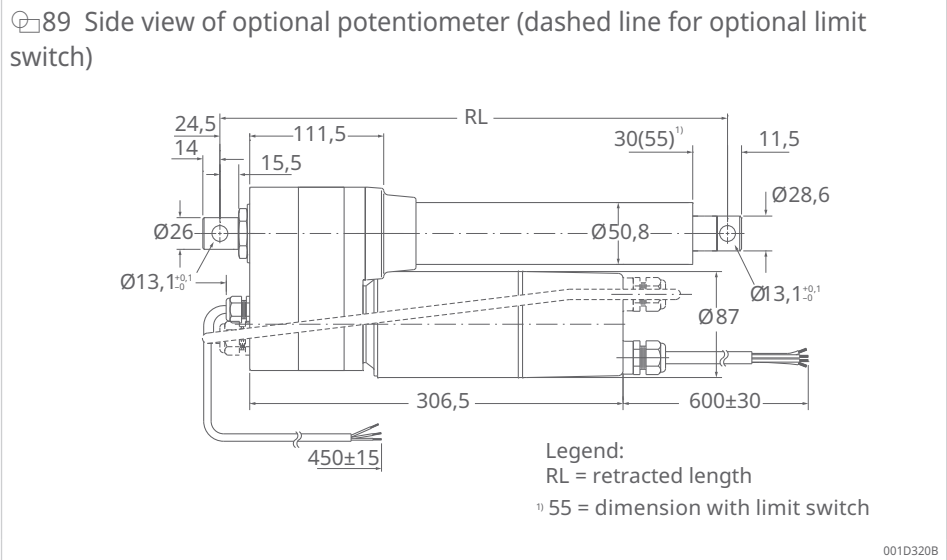

43 Calculation of the installation length (RL): optional potentiometer

Stroke	Unit	With limit switch ⁴⁾						Without limit switch ⁵⁾					
		102	153	204	305	457	610	102	153	204	305	457	610
Installation length (RL)	mm	478	478	478	630	782	935	418	453	453	503	706	859

⁴⁾ Tolerance: S and RL = ±5.0 mm (if S ≥ 305 mm, S = ±7.5 mm)

⁵⁾ Tolerance: S = ±2.5 mm and L = ±3.8 mm

Performance diagrams

91 Speed-load diagram for CAHB-30A

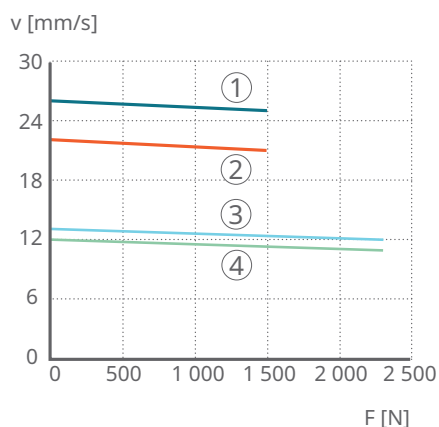

001D179C

1	AC 115 V	2	AC 230 V
3	AC 115 V	4	AC 230 V
F	Load	v	Speed

92 Current-load diagram for CAHB-30A

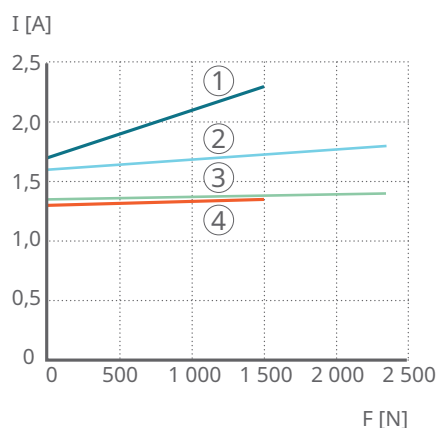

001D179D

1	AC 115 V	2	AC 230 V
3	AC 115 V	4	AC 230 V
F	Load	I	Current consumption

Electrical specifications

44 Potentiometer resolution for CAHB-30A

Stroke	mm	102	153	204	305	457	610
Ω/mm	mm	59.0	59.0	29.5	29.5	9.84	9.84

93 Electrical diagrams for CAHB-30A

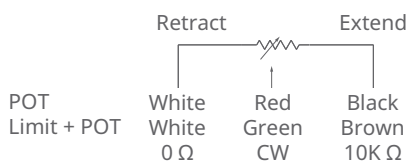

001D324A

94 Connection diagram for CAHB-30A

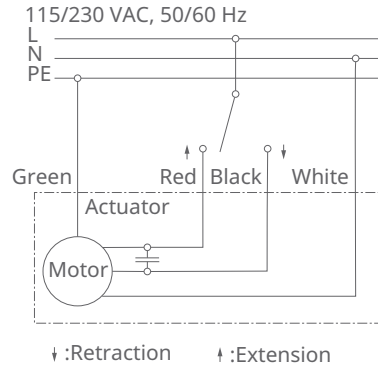

001D322B

95 Connection diagram for CAHB-30A with limit switch

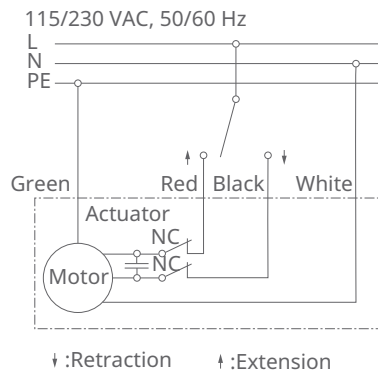

001D323B

Attachment orientation

96 Attachment orientation for CAHB-30A

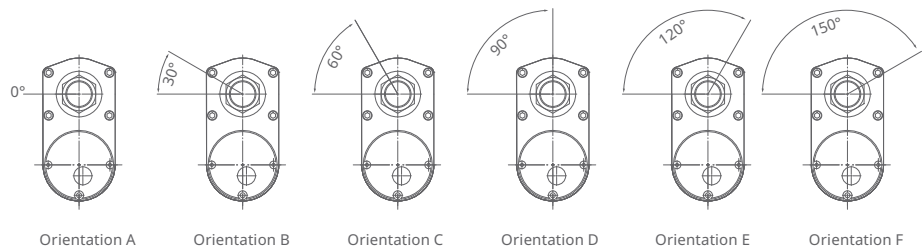

001D321B

Ordering key

97 Order designation for CAHB-30A

CAHB +30 N 1 A - 102 380 - A A A 0 0 - 000

Type**Voltage**

N	AC 115 V
P	AC 230 V

Load

1	1500 N
2	2300 N

Screw

A	Ball Screw
---	------------

3 × digital stroke length and 3 × digital retracted length¹⁾ (mm)

Stroke	Retracted length basic conf. ²⁾	With limit switch L	With potentiometer P
102	380	+60	+38
153	415	+25	+38
204	415	+25	+38
305	465	+127	+38
457	668	+76	+38
610	821	+76	+38

Degree of protection

A	Standard (IP 65)
---	------------------

Attachment diameter (Front and rear)

A	Standard (hole: Ø13.1 mm)
X	Customized, available on request

Attachment orientation (Front and rear)

A	Standard (0°)
B	30°
C	60°
D	90°
E	120°
F	150°
X	Customized, available on request

Option 1

0	None
L	Limit switch (only for load version 2 300 N)

Option 2

0	None
P	Potentiometer

Customization

¹⁾ Use the letter "A" to represent "10" if the retracted length exceeds 999 mm, for example: 1002 mm becomes A02

²⁾ Basic configuration: the retracted length: without "limit switch", without "potentiometer"

001E0295

12 CAHB-31N

98 CAHB-31N



001CF056

12

Benefits

- powered by AC voltage
- high efficiency
- designed and tested for harsh environments
- reliable and cost-effective
- reduced development and startup times
- virtually maintenance-free

Characteristics

- optional potentiometer and limit switches
- Ball screw with a brake
- self-locking
- integrated thermal and overload protection
- robust design, IP65, wide temperature range, corrosion resistant

45 Technical information for the CAHB-31N

Characteristic	Unit	CAHB-31N...1	CAHB-31N...2	CAHB-31N...3
Rated push force	N	2300	4500	6000
Rated pull force	N	2300	4500	6000
Holding force ¹⁾	N	13600	13600	13600
Speed (full load ... no load)	AC 115 V/60 Hz	mm/s	48 to 57	22 to 28
	AC 230 V/50 Hz	mm/s	40 to 50	20 to 24
Stroke S	mm	102 to 610	102 to 610	102 to 610
Voltage	V AC	115 / 230	115 / 230	115 / 230
Nominal current	AC 115 V/60 Hz	A	3	2.6
	AC 230 V/50 Hz	A	1.5	1.4
Duty cycle of operation	%	25	25	25
ON time / OFF time	s	94 / 376	94 / 376	94 / 376
Ambient temperature	°C	-26 to +65	-26 to +65	-26 to +65
IP protection	-	IP65S	IP65S	IP65S
Mass	kg	9.5	9.5	9.5
Color	-	Black	Black	Black

¹⁾ The holding force is the highest load a powered-down drive can statically hold without slipping backward.

Basic configuration (dashed line for optional limit switch)

12

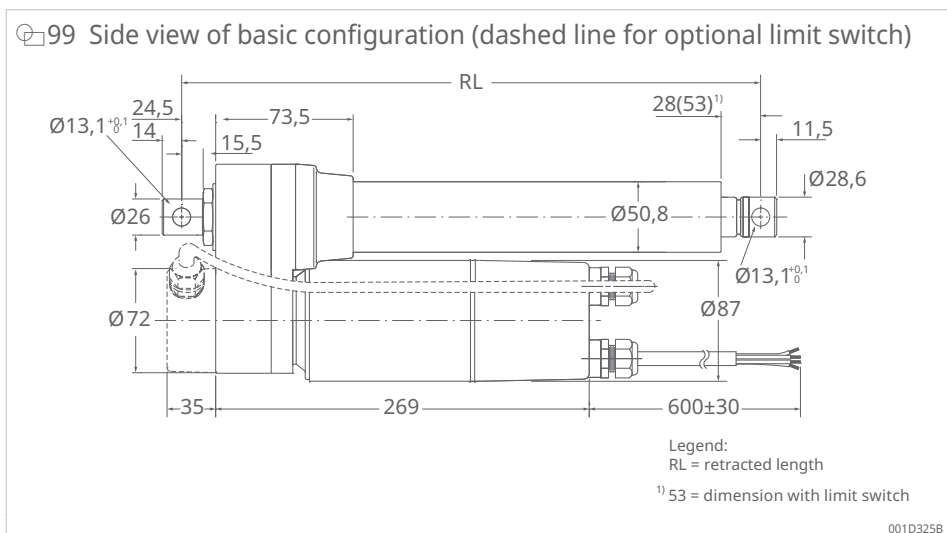

100 Rear view

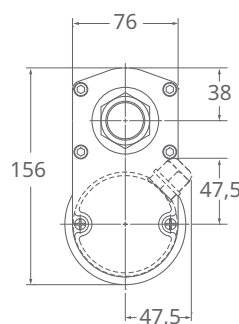

46 Calculation of the installation length (RL): basic configuration

Stroke	Unit	With limit switch ²⁾						Without limit switch ³⁾					
		102	153	204	305	457	610	102	153	204	305	457	610
Installation length (RL)	mm	444	444	495	659	811	964	380	419	419	521	735	888

²⁾ Tolerance: S and RL = ±5.0 mm (if S ≥ 305 mm, S = ±7.5 mm)

³⁾ Tolerance: S = ±2.5 mm and L = ±3.8 mm

Optional potentiometer (dashed line for optional limit switch)

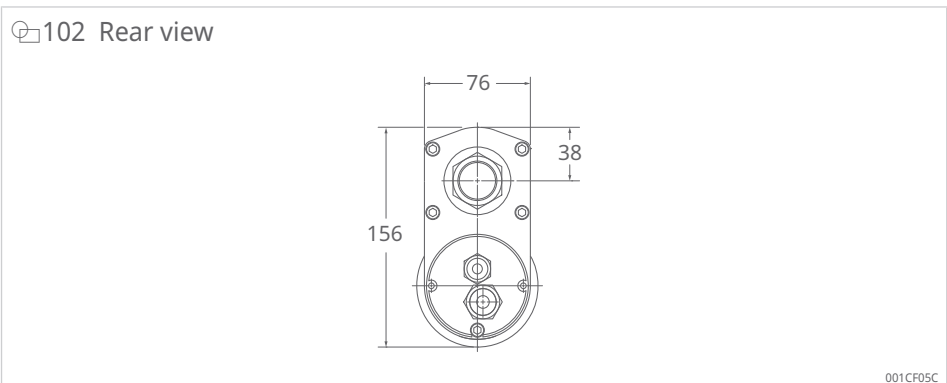
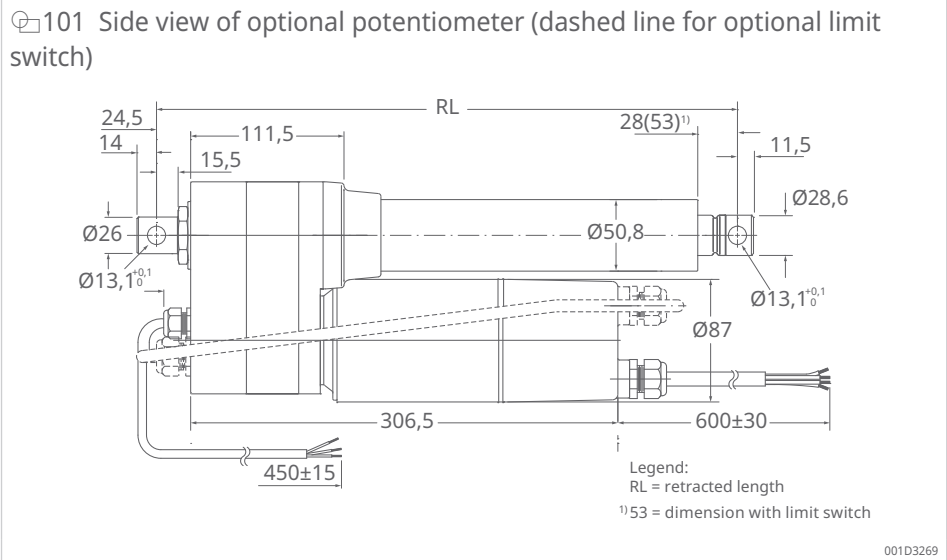

47 Calculation of the installation length (RL): optional potentiometer

Stroke	Unit	With limit switch ⁴⁾						Without limit switch ⁵⁾					
		102	153	204	305	457	610	102	153	204	305	457	610
Installation length (RL)	mm	482	482	533	697	849	1002 (code A02)	418	457	457	559	773	926

⁴⁾ Tolerance: S and RL = ±5.0 mm (if S ≥ 305 mm, S = ±7.5 mm)

⁵⁾ Tolerance: S = ±2.5 mm and L = ±3.8 mm

Performance diagrams

103 Speed-load diagram for CAHB-31N

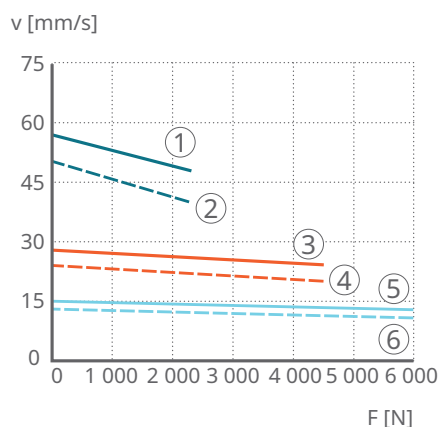

001D17A0

1	AC 115 V	2	AC 230 V
3	AC 115 V	4	AC 230 V
5	AC 115 V	6	AC 230 V
F	Load	v	Speed

12

104 Current-load diagram for CAHB-31N

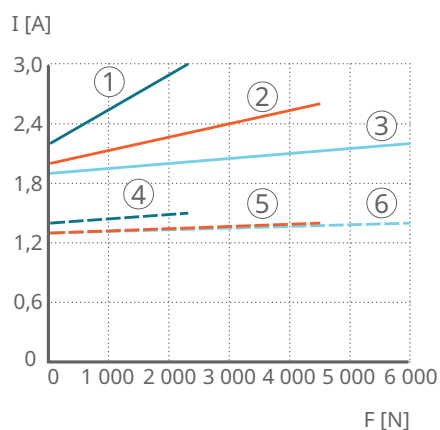

001D17A2

1	AC 115 V	2	AC 230 V
3	AC 115 V	4	AC 230 V
5	AC 115 V	6	AC 230 V
F	Load	I	Current consumption

Electrical specifications

48 Potentiometer resolution for CAHB-31N

Stroke	mm	102	153	204	305	457	610
Potentiometer resolution	Ω/mm	59.0	59.0	29.5	29.5	9.84	9.84

105 Electrical diagrams for CAHB-31N

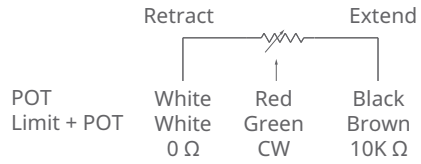

001D32AA

106 Connection diagram for CAHB-31N

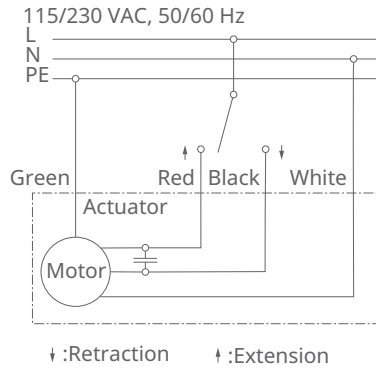

001D322B

107 Connection diagram for CAHB-31N with limit switch

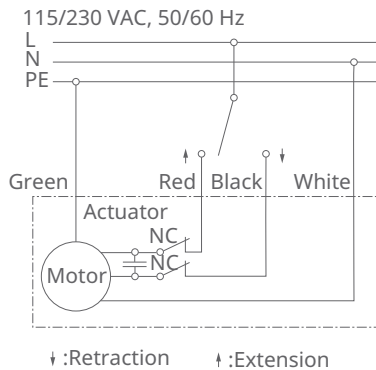

001D323B

Attachment orientation

108 Attachment orientation for CAHB-31N

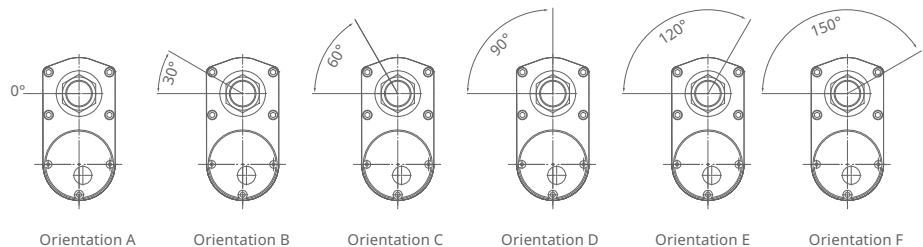

001D327B

Ordering key

109 Order designation for CAHB-31N

CAHB - 31 N 1 - N - 102 380 - A A A 0 0 - 000

Type**Voltage**

N	AC 115 V
P	AC 230 V

Load

1	1500 N
2	2300 N
2	2300 N

Screw

N	Ball Screw
---	------------

3 × digital stroke length and 3 × digital retracted length¹⁾ (mm)

Stroke	Retracted length basic conf. ²⁾	With limit switch L	With potentiometer P
102	380	+64	+38
153	419	+25	+38
204	419	+76	+38
305	521	+138	+38
457	735	+76	+38
610	888	+76	+38

Degree of protection

A	Standard (IP 65)
---	------------------

Attachment diameter (Front and rear)

A	Standard (hole: Ø13.1 mm)
X	Customized, available on request

Attachment orientation (Front and rear)

A	Standard (0°)
B	30°
C	60°
D	90°
E	120°
F	150°
X	Customized, available on request

Option 1

0	None
L	Limit switch (only for load version 6 000 N)

Option 2

0	None
P	Potentiometer

Customization

¹⁾ Use the letter "A" to represent "10" if the retracted length exceeds 999 mm, for example: 1002 mm becomes A02

²⁾ Basic configuration: the retracted length: without "limit switch", without "potentiometer"

001E02A5

13 CAHB – Environmental tests

49 Climatic tests for CAHB..E, CAHB-10, CAHB-30A, CAHB-31N

Test and Standard	CAHB..E		CAHB-10		CAHB-30A, CAHB-31N	
	Performance	Report No.	Performance	Report No.	Performance	Report No.
Cold test EN60068-2-1 (Ab)	Storage at low temperature	PH_TR0295	Storage at low temperature	"Low temperature for CAHB-10"	Storage at low temperature	PH_TR0265
	Temperature: -40 °C		Temperature: -40 °C		Temperature: -40 °C	
	Duration: 6 h		Duration: 96 h		Duration: 8 h	
	Not connected		Not connected		Not connected	
	Tested at room temperature.		Tested at room temperature.		Tested at room temperature.	
Cold test EN60068-2-1 (Ad)	Storage at low temperature	PH_TR0295	Storage at low temperature	"Low temperature for CAHB-10"	Storage at low temperature	PH_TR0265
	Temperature: -30 °C		Temperature: -20 °C		Temperature: -26 °C	
	Duration: 6 h		Duration: 96 h		Duration: 8 h	
	Linear drive is not activated/connected		Linear drive is not activated/connected		Not connected	
	Tested at low temperature.		Tested at low temperature.		Tested at room temperature.	
Dry heat EN60068-2-2 (Bb)	Storage at high temperature	PH_TR0278	Storage at high temperature	"High temperature for CAHB-10"	-	-
	Temperature: +90 °C		Temperature: +85 °C			
	Duration: 72 h		Duration: 96 h			
	Linear drive is not activated/connected.		Linear drive is not activated/connected.			
	Tested at room temperature		Tested at room temperature			
Change of temperature EN60068-2-14 (Na)	Rapid change of temperature	PH_TR0278	-	-	-	-
	High temperature: +100 °C over 60 min					
	Low temperature: -30 °C over 60 min					
	Transition time: < 10 s					
	Duration: 100 cycles					
	Linear drive is not activated/connected.					
	Tested at room temperature.					
Salt mist EN60068-2-52 (Kb)	Salt spray test	PH_TR0268	Salt spray test	"Salt spray test for CAHB-10"	-	-
	Salt solution: 5 % sodium chloride (NaCl)		Salt solution: 5 % sodium chloride (NaCl)			
	4 spray period, 2 h at a time.		4 spray period, 2 h at a time.			
	Humidity storage for 7days after each test		Humidity storage for 7days after each test			
	Linear drive not activated/connected.		Linear drive not activated/connected.			
	Exposure time: 250 h		Exposure time: 96 h			

13

Test and Standard	CAHB..E		CAHB-10		CAHB-30A, CAHB-31N	
	Performance	Report No.	Performance	Report No.	Performance	Report No.
Protection class IEC 60529	1st Test subject: IP6XM	SHIN160703 6235PS	1st Test subject: IPX6S	COM12- GPE080184A N, COM12- GPE080183A N	-	-
	Test condition: movement		Test condition: static			
	Dust used in testing: talcum powder		Type of dust: talcum powder			
	Dust concentration: 2 kg/m ³					
	Chamber volume, dust is kept in suspension during the test					
	Test duration: 8 h		Test duration: 8 h			
Protection class IEC 60529	2. Test subject: IPX6M	SHIN160703 6235PS	2. Test subject: IPX6S	COM12- GPE080184A N, COM12- GPE080183A N	2. Test subject: IPX5S	SHIN160804 2057MR
	Test condition: movement		Test condition: static			
	Flow: 100 l/min		Flow: 100 (1 ±5 %) l/min			
	Nozzle diameter: Ø12.5 mm		Nozzle diameter: Ø12.5 mm			
	Distance: 2.5 ~ 3.0 m		Distance: 2.5 ~ 3.0 m			
	Test duration: 3 min		Test duration: 3 min			
Protection class ISO 20653:2013	3. Test subject: IPX9K	SHIN160703 6235PS	3. Test subject: IPX9K	SHIN151004 8959MR-01	-	-
	Test condition: static		Test condition: static			
	Water flow: 14-16 l/min		Water flow: 14~16 l/min			
	Water pressure: 8000~10000 kPa		Water pressure: 8000~10000 kPa			
	Water temperature: 80 to -5 °C		Water temperature: 80 to -5 °C			
	Test angle: 0°, 30°, 60°, 90°		Test angle: 0°, 30°, 60°, 90°			
	Test distance from jet to sample: 100~150 mm		Test distance from jet to sample: 100~150 mm			
	Test duration: 30 s/ position		Test duration: 30 s/ position			
Resistance to chemical product	-	-	Reagent on the surface, 3days	SHIN210402 0949MR-01	-	-
			100 h			
			0# Diesel			
			Mobile H46 antiwear hydraulic			
			Hydraulan DOT brake oil			
			Ethylene glycol solution 50 %			
			Urea saturated solution			
			DEF			
			NPK (15-15-15)			

50 Climatic tests for CAHB..S

Test and Standard	CAHB..S	
	Performance	Report No.
Temperature shock test	-55 °C to +95 °C, ≤15 S	SHIN2007039234MR
	100 cycles	
Temperature cycle test	-40 °C to +85 °C 18 h/cycle	SHIN2106042981PS
	10 cycles	

Test and Standard	CAHB..S	
	Performance	Report No.
High temperature soak test (Operational)	+85 °C, 96 h	SHIN2012077900MR-01
Low temperature soak test (Operational)	-40 °C, 96 h	SUIN2101000352MR
Storage temperature	-55 °C to +110 °C, 24 h	SUIN2012009686MR
Humidity and temperature cycles ISO16750-4:2010 Section 5.6	+25 °C, 95 %rF to+55 °C, 95 %rF	SUIN2012009687MR
	24 h/cycle, 6 cycles	
Salt mist EN60068-2-52 (Kb)	500 h	PH_TR0404
Protection class IEC 60529	IP6xS, IP6xM	SHIN1607036235PS
Degree of protection ISO 20653:2013	IPx9K	SHIN1607036235PS
Resistance to chemical product	Reagent on the surface, 3days	SHIN2104020959MR
	100 h	
	0# Diesel	
	Mobile H46 antiwear hydraulic	
	Hydraulan DOT brake oil	
	Ethylene glycol solution 50 %	
	Urea saturated solution	
	DEF	
	NPK (15-15-15)	

51 Mechanical tests for CAHB..E, CAHB-10, CAHB-30A, CAHB-31N

Test and Standards	CAHB..E		CAHB-10		CAHB-30A, CAHB-31N	
	Performance	Report No.	Performance	Report No.	Performance	Report No.
Vibration EN60068-2-6 (Fdb) EN60068-w2-6 (Fc)	Test subject: random vibration		-	-	-	-
	Frequency (Hz)	Spectral				
	(g2/Hz)	Power density				
	10	0.005				
	200	0.02				
	300	0.01				
	350	0.002				
	Test direction: X/Y/Z axis					
	Test duration: 2 h/axis, 6 h total					
	Test subject: sine wave					
	Test Condition:					
	Frequency range: 5~25~200 Hz					
	Amplitude: 3.3 mm (p-p)					
	Acceleration: 4 g					
Sweep speed: 10 ct/min						
Test direction: X/Y/Z axis						
Test duration: 2 h/axis, 6 h total						
Vibration Conditions specified by Schaeffler	-		-		-	
	-		Test Item:		SHIN18050	
	-		Vibration nominal value (g-eff)	Dwell time (min)	34119SC	
	-		5	10	SHIN18050	
	-		10	10	32588SC	
	-		15	10		
	-		20	10		
	-		20	20		
	-		20	30		
	-		Test equipment designation			
-		Hold tester	Typhoon 2.5+			

13

52 Mechanical tests for CAHB..S

Test and Standard	CAHB..S	
	Performance	Report No.
Mechanical shock	245~500 m/s ²	SUIN2106004489MR
	3~100 impacts/axis	
Mechanical shock (Drop)	1-m height onto concrete	PH_TR0430
Random vibration for AG/CE wheeled vehicle	24 h/axis	SUIN2106004491MR
	5 Hz at a spectral acceleration density of 5.29 (m/s ²) ² /Hz	
	100 Hz at a spectral acceleration density of 14.44 (m/s ²) ² /Hz	
	1000 Hz at a spectral acceleration density of 14.44 (m/s ²) ² /Hz	
Vibration-random resistance	2000 Hz at a spectral acceleration density of 3.66 (m/s ²) ² /Hz	SHIN2011076082PS
	6.9 g-eff	
	2 h/axis	

53 Electrical tests for CAHB..E, CAHB-10, CAHB-30A, CAHB-31N

Test and Standards	CAHB..E		CAHB-10		CAHB-30A, CAHB-31N	
	Performance	Report No.	Performance	Report No.	Performance	Report No.
Power supply DC 12 V ASAE EP455 (1990)	Supply voltages: +10 V ~ +16 V	PH_TR0267 PH_TR0302	-	-	-	-
	Over voltage: +26 V/5 min					
	Reverse polarity: -26 V/5 min					
	Short-circuit to ground: 16 V/5 min					
	Short-circuit to positive: 16 V					

Test and Standards	CAHB..E		CAHB-10		CAHB-30A, CAHB-31N	
	Performance	Report No.	Performance	Report No.	Performance	Report No.
Power supply DC 24 V ASAE EP455 (1990)	Supply voltages: +21 V ~ +26 V Over voltage: +36 V/5 min Reverse polarity: -36 V/5 min Short-circuit to ground: 32 V/5 min Short-circuit to positive: 32 V	PH_TR0267 PH_TR0302	-	-	-	-
Safety menu Low Voltage Directive EN 60335-1: 2012 + A11: 2014	-	-	-	-	Rated voltage: AC 230 V Rated frequency: 50 Hz Nominal current: 1.5 A Degree of protection: IP65	UL 4787638796
EN 60335-2-97: 2006 + A11: 2008 + A2:2010 + A12: 2015 EN 62233: 2008	-	-	-	-	Rated voltage: AC 230 V Rated frequency: 50 Hz Nominal current: 1.5 A Degree of protection: IP65	UL 4787638796
EMC, HF immunity EN 61000-6-1	-	-	Test passed for 12-V/24-V-motor	70.888.12.1 063.02	-	-
EN 61000-6-2	Test passed for 12-V/24-V-motor	7088816881 02-00				
EMC, emitted interference EN 61000-6-3	-	-	Within the limits for 12 V/24 V motors	70.888.12.1 063.02	-	-
EN 61000-6-4	Within the limits for 12 V/24 V motors	7088816881 02-00	-	-	-	-
EN 50081-2 (1993) EN 55011 (1998)	-	-	-	-	Class B	EM99777 (IA4=CAHB-30 CAHB-31 series)
EMC, interference in motor vehicles ISO 7637-2	ISO 7637 load dump test only accepted on motor power connection	7088816881 03-00	-	-	-	-
UL certification					UL 325 ANSI/CAN/UL-Door	20190822-E507157
UL registration	Cable flammability test VW-1 (UL758, UL1581, CSA C22.2 N°.210)	BELDEN E357312-S 2C14 SHIELDED BELDEN E357312-S 3C22 2C14 BELDEN E357312-S 2C14 4C26				

13

 54 Electrical tests for CAHB..S

Test and Standard	CAHB..S	
	Performance	Report No.
Electrical "Steady State" load DC 12 V ISO 16750-2, 3rd output	<ul style="list-style-type: none"> Supply voltage: 14 ± 0.2 (motor running), 12 ± 0.2 (motor not running) Over voltage: 18 V/60 min Reverse polarity: -26 V/5 min Short-circuit to ground: 16 V/5 min Short-circuit to positive: 16 V/1 min/10 times Jump start: 24 V/60±6 s Ground reference and supply offset: supply line offset ±2 V, ground line offset ±1 V. Ground reference disconnection Power supply disconnection Superimposed AC voltage on supply lines: 16 V/Upp 4 V/120 s/ 5 times Start cycle: level I to IV/tol. -0.2 V/duration ±10 % Gradual decrease and increase of the supply voltage: min. supply 6-10 V, max. supply 16-21 V, 0.5 V/min Momentary drop in supply voltage: 100 ms/4.5 V Recovery behavior after drop in supply: min. voltage 4.5 V 0.5 V/ 10 s reduction Load shedding: test A (without central protection) 100 V/ 400 ms/1 Ω (valid for 12-V version, protection code "U") 	WTU21U03019493V-2 (valid for 12-V version, protection codes "T" and "U")
Electrical "Steady State" load DC 24 V ISO 16750-2, 3rd output	<ul style="list-style-type: none"> Supply voltage: 28±0.2 (motor running), 24±0.2 (motor not running) Over voltage: 36 V/60 min Reverse polarity: -36 V/5 min Short-circuit to ground: 32 V/5 min Short-circuit to positive: 32 V/1 min/10 times Jump start: 36 V/60±6 s Ground reference and supply offset: supply line offset ±2 V, ground line offset ±1 V. Ground reference disconnection Power supply disconnection Superimposed AC voltage on supply lines: 32 V/Upp 4 V/120 s/ 5 times Start cycle: level I to III/voltage tol. -0.2 V/duration ±10 % Gradual decrease and increase of the supply voltage: min. supply 8 - 18 V, max. supply 32 V, 0.5 V/min Momentary drop in supply voltage: 100 ms/9 V Recovery behavior after drop in supply: min. voltage 10 V 0.5 V/ 10 s reduction Load shedding: test B (with central protection) 58 V/350 ms/2 Ω (valid for 24-V version, protection code "T") 	WTU21U03019492V-2 (valid for 24-V version, protection code "T")
Sinusoid Changes of Supply Voltage	12-V systems: test level: Vb1: 12 V, Vb2: 6 V, Vb3: 8 V 24-V systems: test level: Vb1: 24 V, Vb2: 8 V, Vb3: 10 V	WTU21U03019493V-2 (valid for 12-V version, protection code "T") WTU21U03019492V-2 (valid for 24-V version, protection code "T")
EMC, transient conducted disturbances ISO 7637-3	CCC, ICC	WTU21U03019493V-1 (valid for 12-V version, protection code "T") WTU21U03019492V-1 (valid for 24-V version, protection code "T")
EMV, conducted disturbances on power lines ISO 7637-2	Positive Inductance Transient Tests Pulse 2a 2b Positive and Negative Burst Coupling Tests Pulse 3a 3b Pulse 4, Cranking Test Cranking Test at Low Temperature Pulse 4	WTU21U03019493V-1 (valid for 12-V version, protection code "T") WTU21U03019492V-1 (valid for 24-V version, protection code "T")

Test and Standard	CAHB..S	Report No.
	Performance	
EMC, conducted emissions/interferences	Class 3	WTU21U08086163V (valid for 12-Vversion, protection code "T")
EMC, conducted emission EN 61000-6-4	0.15 MHz ... 0.5 MHz QP = 79, AV=66 (dBµV) 0.5 MHz ... 30 MHz QP = 73, AV=60 (dBµV)	EED39M000483 (valid for 12-Vversion, protection code "T")
EMC Radiated Emissions/Interference Test CISPR 25-2008	Class 3	WTU21U08086163V (valid for 12-Vversion, protection code "T")
EMC, radiated emission EN 61000-6-4	30 MHz ... 230 MHz QP = 50 (dBµV/m) 230 MHz ... 1000 MHz QP = 57 (dBµV/m)	EED39M000483 (valid for 12-Vversion, protection code "T") EED39M000482 (valid for 24-Vversion, protection code "T")
EMC Radiated Emission EN55011	Class A	WTU21U09098252E (valid for 24-V version, protection code "V")
EMC, discharge of static electricity IEC61000-4-2	Air discharge: ±8 kV Contact discharge: ±4 kV	EED39M000483 (valid for 12-Vversion, protection code "T") EED39M000482 (valid for 24-Vversion, protection code "T")
EMC, electrical fast transient/burst immunity (EFT) IEC61000-4-4	5 kHz, 5/50 ms, 15 ms, 300 ms Supply line ±2 kV, signal line ±1 kV	EED39M000483 (valid for 12-Vversion, protection code "T") EED39M000482 (valid for 24-Vversion, protection code "T")
EMC Power-frequency magnetic field immunity IEC61000-4-8	50 Hz, 1 min, XYZ, 30 A/m	EED39M000483 (valid for 12-Vversion, protection code "T") EED39M000482 (valid for 24-Vversion, protection code "T")
UL registration	Cable flammability test VW-1 (UL758, UL1581, CSA C22.2 N°.210)	BELDEN E357312-S 1PR14 1PR26 2C26 BELDEN E357312-S

13

Schaeffler Technologies AG & Co. KG

Georg-Schäfer-Straße 30

97421 Schweinfurt

Germany

www.schaeffler.de/en

info.de@schaeffler.com

In Germany:

Phone 0180 5003872

From other countries:

Phone +49 9721 91-0

All information has been carefully compiled and checked by us, but we cannot guarantee complete accuracy. We reserve the right to make corrections. Therefore, please always check whether more up-to-date or amended information is available. This publication supersedes all deviating information from older publications. Printing, including excerpts, is only permitted with our approval.
© Schaeffler Technologies AG & Co. KG
PDB 111 / 01 / en-US / 2026-06