



## Lubricators

For grease and oil lubrication

Technical Product Information



## Foreword

### Automatic lubricators

The life of lubricants is limited. In their application, they are constantly exposed to mechanical loads, ageing and contamination. For this reason, it is necessary to supply fresh lubricant at defined time intervals and thereby ensure adequate lubrication. Optimal lubrication helps to avoid consequential damage and reduces the risk of application failure.

With the automatic lubricators of the CONCEPT series, it is possible to supply almost all industrial machines and equipment precisely with oil or grease. The product range comprises simple and cost-effective single-point lubrication systems (CONCEPT1) as well as more complex lubrication systems for a larger number of lubrication points (CONCEPT2, CONCEPT4 and CONCEPT8).

### OPTIME lubricators

The smart OPTIME lubricators combine all the advantages of automatic lubrication with award-winning condition monitoring technology. Access to warning messages via a mobile app or web-based dashboard transforms complexity into simplicity and renders the actual condition transparent at all times. The user-friendly system is instrumental in increasing plant availability and enabling significant cost savings.

### Other products

The product range is supplemented by a wide range of accessories for automatic lubricators, manual lubricating tools, unfilled lubricant cartridges and the Schaeffler lubricant program Arcanol. These lubricants stand for very high performance in rolling bearing and linear applications.

# Contents

- 1 System design ..... 6
  - 1.1 CONCEPT1 ..... 6
  - 1.2 OPTIME C1, CONCEPT2, CONCEPT4 and CONCEPT8 ..... 6
  - 1.3 Schaeffler Grease App..... 9
- 2 Electrochemical lubricators..... 10
  - 2.1 CONCEPT1 ..... 10
    - 2.1.1 Technical data..... 13
    - 2.1.2 Connection options and ordering examples..... 14
    - 2.1.3 Type-specific accessories and spare parts..... 18
- 3 Electromechanical lubricators..... 21
  - 3.1 CONCEPT2 ..... 21
    - 3.1.1 Technical data..... 22
    - 3.1.2 Connection options and ordering examples..... 24
    - 3.1.3 Type-specific accessories and spare parts..... 26
  - 3.2 CONCEPT4 ..... 29
    - 3.2.1 Technical data..... 30
    - 3.2.2 Connection options and ordering examples..... 32
  - 3.3 CONCEPT8 ..... 34
    - 3.3.1 Technical data..... 35
    - 3.3.2 Connection options and ordering examples..... 37
    - 3.3.3 Type-specific accessories and spare parts..... 39
- 4 OPTIME lubricators ..... 40
  - 4.1 OPTIME C1 ..... 40
    - 4.1.1 Technical data..... 42
    - 4.1.2 Connection options and ordering examples..... 43
    - 4.1.3 Type-specific accessories and spare parts..... 45
- 5 Cartridges ..... 47
  - 5.1 Filled cartridges ..... 47
  - 5.2 Unfilled cartridges and accessories ..... 50
- 6 Voltage supply ..... 52
- 7 Demo cases..... 54
- 8 Device holders ..... 55
  - 8.1 Device holders for CONCEPT1 and OPTIME C1 ..... 55
  - 8.2 Device holders for CONCEPT2 and CONCEPT8 ..... 56
- 9 Cover kits ..... 57
- 10 Lubricant feed lines, fittings ..... 58
  - 10.1 Hoses ..... 58
  - 10.2 Fittings ..... 61
    - 10.2.1 Connection adapters ..... 61
    - 10.2.2 Hose connector parts..... 62
    - 10.2.3 Extensions ..... 64

---

10.2.4	Connecting pieces .....	64
10.2.5	Reducing nipples.....	64
10.2.6	Check valves .....	65
10.3	Sub-distributors.....	66
10.3.1	Splitters .....	66
10.3.2	Progressive distributors.....	68
10.4	Tools .....	70
10.4.1	Hose cutter.....	70
11	Lubricant application.....	71
11.1	Brushes .....	71
11.2	Lubrication gears .....	72
11.2.1	Straight teeth .....	74
11.2.2	Left hand helical teeth .....	76
11.2.3	Right hand helical teeth.....	78
11.3	Chain lubrication pinions .....	80
11.3.1	Chain lubrication pinions in simplex design .....	82
11.3.2	Chain lubrication pinions in simplex design with spring plate .....	84
11.3.3	Chain lubrication pinions in duplex design.....	86
11.3.4	Chain lubrication pinions in duplex design with spring plate .....	88
11.4	Lubrication rollers.....	90
12	Manual lubrication tools.....	91
12.1	Lever grease gun.....	91
12.1.1	Grease gun.....	93
12.1.2	Selection of Arcanol grease cartridges.....	94
12.1.3	Accessories .....	95
12.2	Drum pumps.....	96
12.2.1	Pneumatic drum pump kits .....	97
12.2.2	Manual drum pump kits.....	99
12.2.3	Spare parts .....	100
12.2.4	Selection of Arcanol container sizes.....	101
12.2.5	Accessories.....	102

# 1 System design

## 1.1 CONCEPT1

The lubricant line connected to the CONCEPT1 lubricator must be kept as short as possible.

Only the hose ARCALUB-C1.HOSE-8X6-PA12-5M with an inside diameter of 6 mm and an outside diameter of 8 mm may be used ▶ 59 | 50.

1 Maximum lubricant line length  $L_{max}$

Lubricator	$L_{max}$
	m
CONCEPT1 with grease	0,5
CONCEPT1 with oil	2

## 1.2 OPTIME C1, CONCEPT2, CONCEPT4 and CONCEPT8

In the design of the lubrication system for the OPTIME C1, CONCEPT2, CONCEPT4 and CONCEPT8 lubricators the maximum lubricant line length must be calculated.

### 1.2.1 Lubricant line length for grease lubrication

The maximum lubricant line length  $L_{max}$  is dependent in the case of grease lubrication on:

- the delivery pressure of the lubricator
- the grease temperature
- the grease
- the inside diameter of the lubricant line
- the pause times between the pump strokes

$L_{max}$  is calculated as follows:

1		
$L_{max} = \frac{p_{max}}{p_L} \cdot K_S \cdot K_P$		
$L_{max}$	m	Maximum lubricant line length
$p_{max}$	bar	Maximum delivery pressure of the lubricator
$p_L$	bar/m	Pressure loss in lubricant line
$K_S$	–	Correction factor for inside diameter of lubricant line
$K_P$	–	Correction factor for pause time between pump strokes

2 Maximum delivery pressure  $p_{max}$

Lubricator	$p_{max}$
	bar
OPTIME C1 (battery)	10
CONCEPT2 (battery)	30
CONCEPT2 (DC 24 V)	50
CONCEPT4 (DC 24 V)	70
CONCEPT8 (DC 24 V)	70

The pressure loss  $p_L$  in the lubricant line is dependent on the grease group used (0 to 5). The pressure loss increases as the temperature  $T$  of the lubricant decreases. Technical advice must be sought from Schaeffler if the lubricant exceeds a certain temperature.

1 Pressure loss  $p_L$  in lubricant line

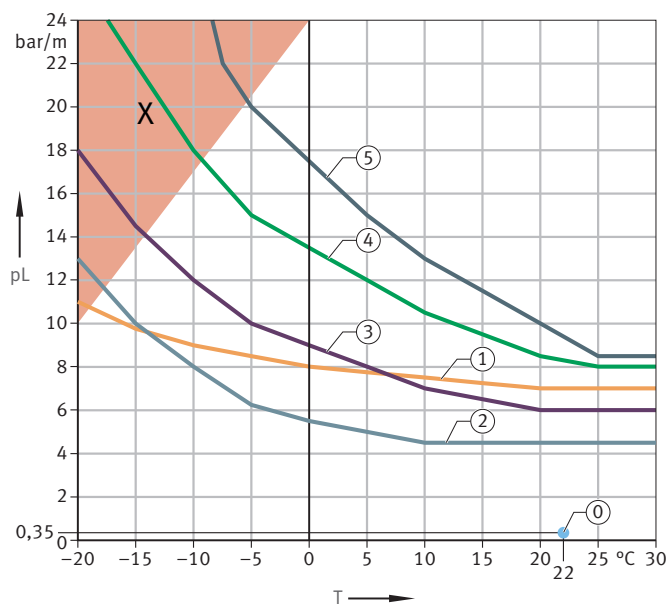

001A8FEB

$p_L$	Pressure loss	$T$	Temperature of the grease
X	Technical advice necessary		

3 Arcanol grease groups

Grease group	Grease
0 <sup>1)</sup>	Arcanol SEMIFLUID
1	Arcanol FOOD2
	Arcanol MOTION2
	Arcanol SPEED2,6
2	Arcanol LOAD460
	Arcanol TEMP120
3	Arcanol LOAD150
	Arcanol LOAD220
	Arcanol LOAD400
	Arcanol MULTI2
	Arcanol MULTITOP
	Arcanol TEMP110
4	Arcanol TEMP200
	Arcanol CLEAN-M
	Arcanol LOAD1000
	Arcanol MULTI3
5	Arcanol TEMP90
	Arcanol VIB3

1) Follow the guidelines on grease group 0 ►8|.

4 Correction factor  $K_S$

Inside diameter of lubricant line mm	$K_S$
6	1,3
5	1
4	0,65
2,5 <sup>2)</sup>	0,35

<sup>2)</sup> Diameter only permissible for grease group 0.

5 Correction factor  $K_P$

Pause time between 2 pump strokes h	$K_P$
$\geq 3$	1
$< 3$	0,65

 The procedure described here for calculating the maximum lubrication line length is only valid for a simple lubricant line without additional components such as splitters, progressive distributors or angled hose connector parts.

Guidelines on grease group 0

The following applies to grease group 0:

- The lubricating grease Arcanol SEMIFLUID is approved for use with all Schaeffler monorail guidance systems in combination with the electromechanical CONCEPT devices.
- Lubricant line length  $> 30$  m only after consultation with Schaeffler.
- Lubricant line inside diameter of 2,5 mm should be used in preference. When used in combination with Schaeffler DuraSense, for example, this diameter provides the following advantages:
  - faster lubricant delivery
  - optimised distribution of grease to the end pieces of the carriages

 Calculation of the lubricant line length is currently only validated for an operating temperature of  $+22$  °C.

Design example for  $L_{max}$  with grease lubrication

6 Initial data

Initial data	CONCEPT8 (DC 24 V)
Lubricant	Arcanol MULTITOP (grease group 3)
Grease temperature	$+20$ °C
Inside diameter of hose	5 mm
Pause time between 2 pump strokes	5 h

7 Calculation of the maximum lubricant line length  $L_{max}$

Delivery pressure	$p_{max}$	70 bar
Pressure loss	$p_L$	6 bar/m
Correction factor	$K_S$	1
Correction factor	$K_P$	1
Maximum lubricant line length	$L_{max}$	$\approx 11,6$ m



### 1.2.2 Lubricant line length for oil lubrication

For oil lubrication with lubricators OPTIME C1, CONCEPT2, CONCEPT4 and CONCEPT8, the maximum lubricant line length  $L_{\max}$  is:

8 Maximum lubricant line length  $L_{\max}$

Lubricator	$L_{\max}$ m
OPTIME C1	5
CONCEPT2	100
CONCEPT4	100
CONCEPT8	100

### 1.3 Schaeffler Grease App

Based on its rolling bearing and tribology expertise, Schaeffler offers a digital assistant which can be used to determine lubrication parameters.

Schaeffler customers can use the Grease App to calculate specific values for the grease lubrication of rolling bearings:

- initial quantity of grease required for the rolling bearing
- relubrication intervals
- relubrication quantities
- recommendation of suitable Arcanol lubricants and associated properties
- cartridge setting recommendations for the CONCEPT1 lubricator

The calculation takes into account different cage designs and cage geometries and determines the free volume in the rolling bearing, thus allowing the relevant lubricant parameters to be precisely determined.

The Schaeffler Grease App can be accessed via the QR code or via the URL <https://greaseapp.com/>

2 QR code to the website

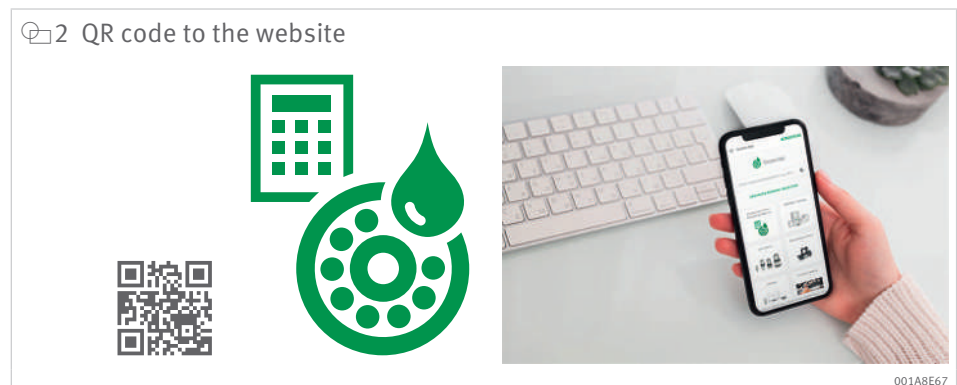

001ABE67

## 2 Electrochemical lubricators

### 2.1 CONCEPT1

The CONCEPT1 lubricators to protection class IP68, which are certified for use in potentially explosive environments, offer a cost-effective and versatile solution for supplying equipment with grease or oil.

The lubricant is dispensed using gas pressure, which is built up by means of an electrochemical drive unit. An external voltage supply is not required.

The lubricators are available filled with selected Arcanol lubricants or unfilled.

As each lubricator can be filled multiple times, the CONCEPT1 is particularly sustainable. Only the drive unit must be replaced when refilling.

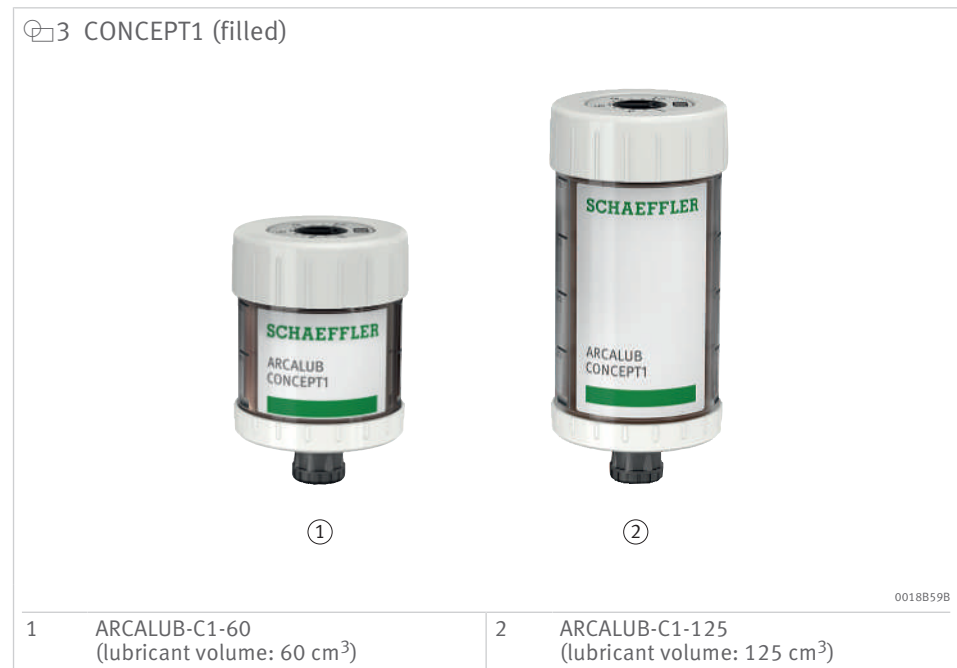

#### Advantages of the CONCEPT1 lubricator

- flexible: the customer can choose between lubricators filled with Arcanol lubricant from Schaeffler and unfilled lubricators that can be filled with other lubricants
- sustainable: the lubricators can be filled up to 3 times to help conserve the environment
- cost-effective: good/price performance ratio compared with other lubricators of the same device class
- simple conversion: as no special tools are required, the conversion to automatic lubrication with CONCEPT1 is very simple
- ATEX certification and IECEx certification: safe lubrication in potentially explosive environments

### 9 CONCEPT1 with drive unit, prefilled for grease lubrication

Lubricant	V	Quantity <sup>1)</sup>	Ordering number	Ordering designation
	cm <sup>3</sup>			
Arcanol FOOD2	60	10	095249290-0000-10	ARCALUB-C1-60-FOOD2
Arcanol LOAD220	60	10	095249273-0000-10	ARCALUB-C1-60-LOAD220
Arcanol LOAD400	60	10	095249249-0000-10	ARCALUB-C1-60-LOAD400
Arcanol MULTI2	60	10	095249230-0000-10	ARCALUB-C1-60-MULTI2
Arcanol MULTITOP	60	10	095249222-0000-10	ARCALUB-C1-60-MULTITOP
Arcanol TEMP110	60	10	095249214-0000-10	ARCALUB-C1-60-TEMP110
Arcanol FOOD2	125	10	095248897-0000-10	ARCALUB-C1-125-FOOD2
Arcanol LOAD150	125	10	095731784-0000-10	ARCALUB-C1-125-LOAD150
Arcanol LOAD220	125	10	095248870-0000-10	ARCALUB-C1-125-LOAD220
Arcanol LOAD400	125	10	095248854-0000-10	ARCALUB-C1-125-LOAD400
Arcanol LOAD460	125	10	095248838-0000-10	ARCALUB-C1-125-LOAD460
Arcanol MULTI2	125	10	095248820-0000-10	ARCALUB-C1-125-MULTI2
Arcanol MULTITOP	125	10	095248811-0000-10	ARCALUB-C1-125-MULTITOP
Arcanol TEMP110	125	10	095248200-0000-10	ARCALUB-C1-125-TEMP110

1) Quantity per packaging unit

### 10 CONCEPT1 with drive unit, prefilled for oil lubrication

Lubricant	V	Quantity <sup>2)</sup>	Ordering number	Ordering designation
	cm <sup>3</sup>			
Arcanol CHAIN-OIL	60	10	096040432-0000-10	ARCALUB-C1-60-CHAIN-OIL
Arcanol CHAIN-OIL	125	10	095248900-0000-10	ARCALUB-C1-125-CHAIN-OIL
Arcanol FOOD-OIL	125	10	095248889-0000-10	ARCALUB-C1-125-FOOD-OIL

2) Quantity per packaging unit

### 11 CONCEPT1, unfilled

Lubricant	V	Quantity <sup>3)</sup>	Ordering number	Ordering designation
	cm <sup>3</sup>			
–	60	10	095166050-0000-10	ARCALUB-C1-60-REFILLABLE
–	125	10	095166076-0000-10	ARCALUB-C1-125-REFILLABLE

3) Quantity per packaging unit

Unfilled CONCEPT1 lubricators can be filled by the actual customer. This permits the additional flexible use of the lubricators for customer-specific lubricants. Filling accessories are available for the filling operation ►18|2.1.3.2.

Before using customer-specific lubricants, please arrange for Schaeffler to check their suitability.



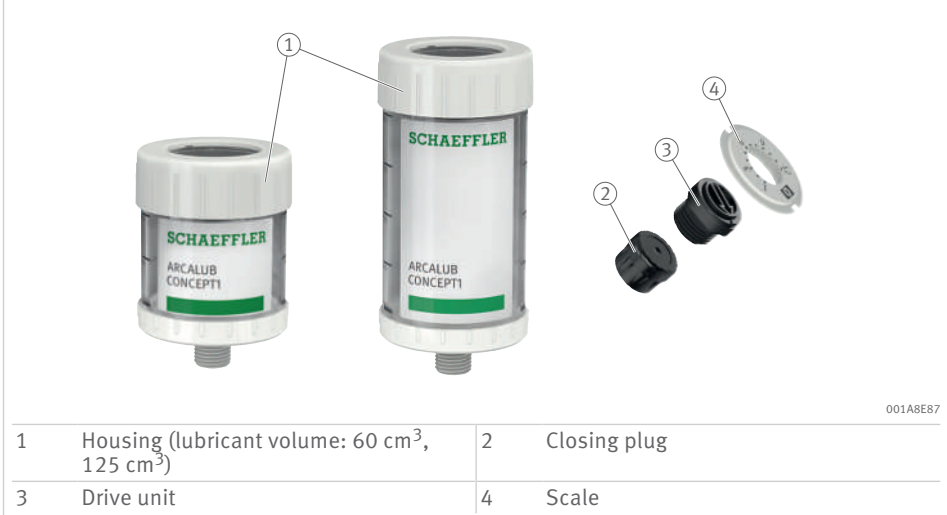

The lubricator may be filled a maximum of 3 times. The correct functioning of the lubricator cannot be ensured if further filling operations are carried out.

 4 CONCEPT1 (unfilled)

### Scope of delivery

A delivery of unfilled CONCEPT1 lubricators contains 10× unfilled housing, 10× drive unit, 10× scale and 10× closing plug.

 The check plug valve ARCALUB-C1.PLUG-OIL-VALVE, which is available separately, is needed to fill the empty dispenser with oil ► 18 |  14.

## 2.1.1 Technical data

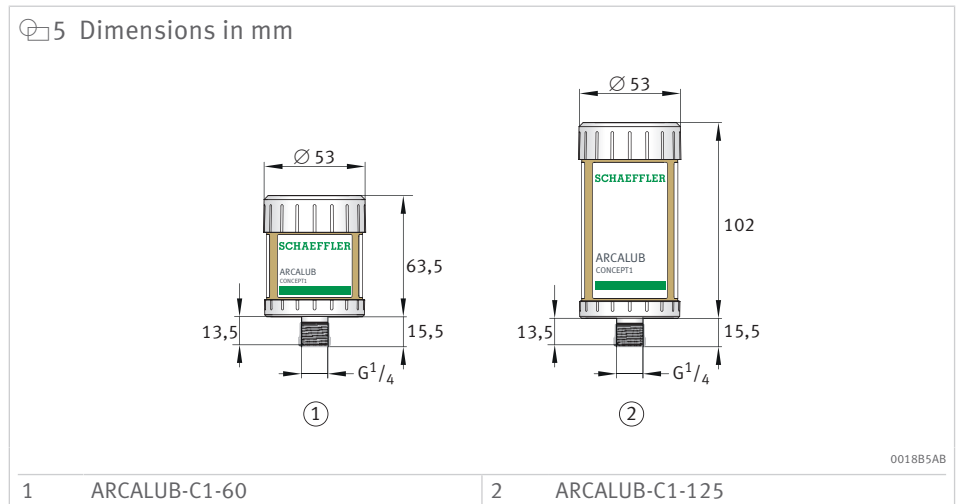

## 12 Technical data

Feature		Value
Dimensions	60 cm <sup>3</sup>	80 mm×52 mm×52 mm
	125 cm <sup>3</sup>	120 mm×52 mm×52 mm
Mass (unfilled)	60 cm <sup>3</sup>	≈ 65 g
	125 cm <sup>3</sup>	≈ 80 g
Mass (filled)	60 cm <sup>3</sup>	≈ 115 g
	125 cm <sup>3</sup>	≈ 190 g
Installation position		As required
Housing material		PET
Protection class		IP68
Explosion protection classification	Certificate	DEKRA 20ATEX0032X IECEX DEK 21.0038X
		II 1G Ex ia IIC T6 G II 1D Ex ia IIIC T <sub>200</sub> 80°C Da I M1 Ex ia I Ma
Lubricant volume		60 cm <sup>3</sup> or 125 cm <sup>3</sup>
Lubricant	Grease	Arcanol range up to NLGI 2 Other greases by agreement
	Oil	> 68 cSt at 40 °C
Dispensing time (steplessly adjustable)		1 month up to 12 months
Functional principle		Gas drive
Operating pressure		≤ 5 bar
Number of outlets		1
Threaded connector		G 1/4"
Number of lubrication points		1, branching not permitted
Operating temperature		-20 °C up to +55 °C (environment)

The CONCEPT1 lubricator meets the requirements for IECEx and has been tested in accordance with the ATEX product directive 2014/34/EU of the European Union. The lubricator is approved for use in almost all potentially explosive environments. The issued approvals are specified in the technical data.



According to the directives governing use in potentially explosive atmospheres, the customer is responsible for assessing the zone in which the device is to be used. Regardless of this, Schaeffler recommends that customers contact Schaeffler for an alignment of their explosion protection requirements with the features of lubricator CONCEPT1.

### 2.1.2 Connection options and ordering examples

An extensive range of accessories allows the lubricators to be used in numerous applications. The use of the appropriate accessory for connection and location is essential for the correct and safe operation of the lubricators.

6 Connection options CONCEPT1

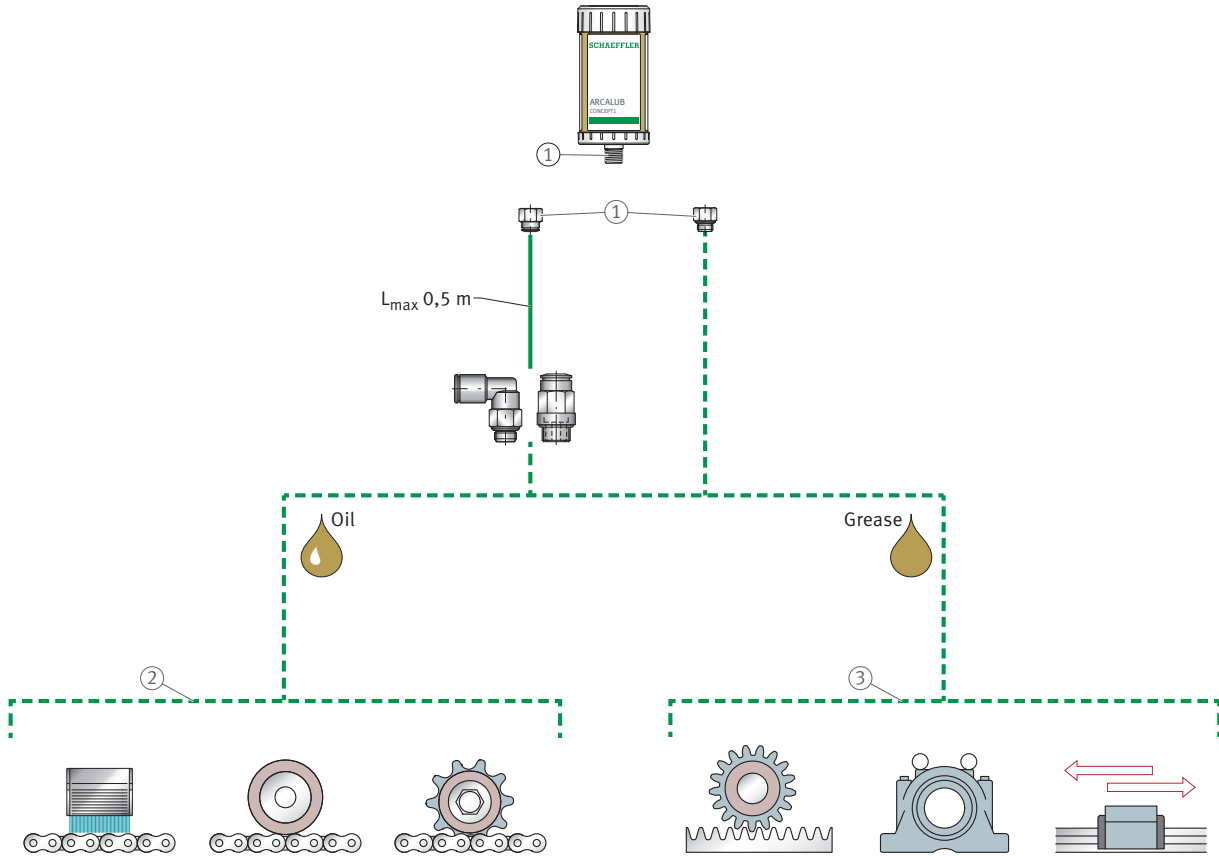

001AA74B

1	Lubricant outlet	2	Oil lubrication of chains using brush or lubrication pinion
3	Grease lubrication of open gears, bearings or linear guidance systems		

7 Lubrication of a rolling bearing in the bearing housing



0018B71C

1 Reducing nipple

8 Mounting using fixing bracket and protective cover



0018B70C

1	Fixing bracket	2	Protective cover
3	Mounting support	4	Hose connector part with internal thread
5	Hose		

9 Lubrication of a chain



0018B72C

1	Magnetic foot for retaining clamp	2	Retaining clamp
3	Brush, round		

10 Lubrication of a gear tooth set

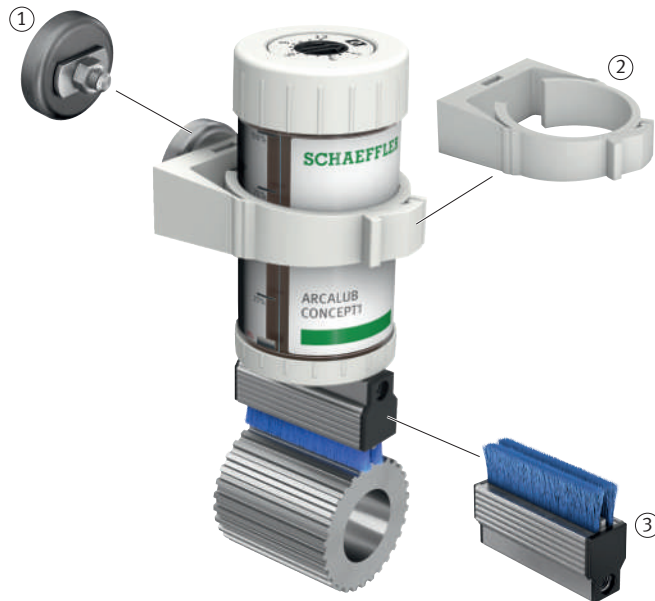

0018B73C

1	Magnetic foot for retaining clamp	2	Retaining clamp
3	Brush for the food industry		



11 Mounting with bulkhead fitting and lubrication by brush



001ACABD

### 2.1.3 Type-specific accessories and spare parts

#### 2.1.3.1 Refilling kits

A refilling kit is required when filling the CONCEPT1 lubricator for the second and third time.

All CONCEPT1 lubricators are suitable for refilling, irrespective of whether they were purchased as a pre-filled or a unfilled version.

##### 13 Refilling kits

Lubricator	Quantity <sup>1)</sup>	Ordering number	Ordering designation
ARCALUB-C1-60	10	095287523-0000-10	ARCALUB-C1.DRYCELL-KIT-60
ARCALUB-C1-125	10	095287540-0000-10	ARCALUB-C1.DRYCELL-KIT-125

<sup>1)</sup> Quantity per packaging unit

#### Scope of delivery

A delivery of a refilling kit contains 10× drive unit, 10× scale, 10× closing plug and 10× new adhesive label.

#### 2.1.3.2 Filling accessories

Special refill nipples are available for filling by lever grease gun or drum pump.

12 Filling accessories

A	Refill nipple (for lever grease gun)	B	Filling adapter (for drum pump)
C	Check plug valve	D	Connecting piece (if required)

001A8EA7

##### 14 Filling accessories

Type	G <sub>1</sub>	Quantity <sup>1)</sup>	Ordering number	Ordering designation
A	G 1/4"	3	095248170-0000-10	ARCALUB-C1.NIPPLE-REFILL-G1/4
B	R 1/4"	1	095248161-0000-10	ARCALUB-C1.NIPPLE-REFILL-GREASE-R1/4
	R 3/8"	1	095248137-0000-10	ARCALUB-C1.NIPPLE-REFILL-GREASE-R3/8
C	–	10	095286780-0000-10	ARCALUB-C1.PLUG-OIL-VALVE
D	G 1/4"	10	095291598-0000-10	ARCALUB-C1.CONNECT-G1/4

<sup>1)</sup> Quantity per packaging unit

Sealing the lubricators after filling:

- The lubricator is sealed after filling with oil using a check plug valve available as an optional accessory. The closing plug is then no longer required.
- The lubricator is sealed after filling with grease using the closing plug. The closing plug is included with unfilled lubricators and in the refilling kit.

13 Refilling the lubricator

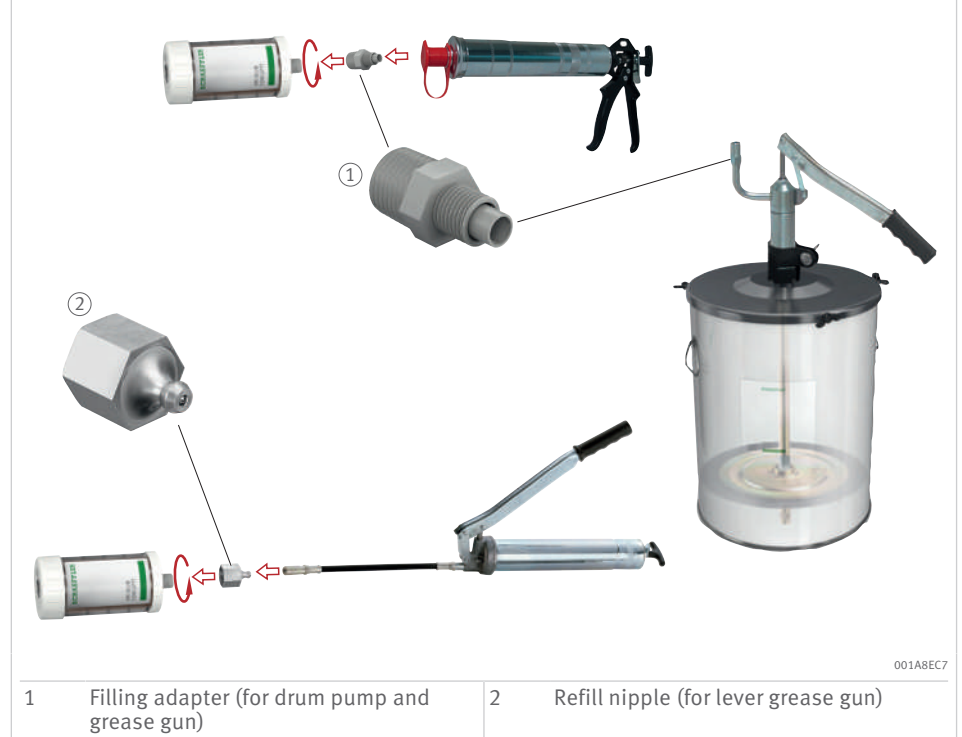

Suitable lever grease guns and drum pumps with accessories (including the connecting piece) can also be obtained from Schaeffler ►91|12.

2.1.3.3 2-Way adapters for CONCEPT1

With 2-way adapters, the capacity of 2 CONCEPT1 or OPTIME C1 lubricators can be combined at one lubrication point. As a result, either twice the lubricant quantity can be dispensed per unit of time or the dispensing time can be doubled.

The adapter must be prefilled with the same lubricant contained in the connected lubricators, via the lateral lubrication nipple, before initial operation.

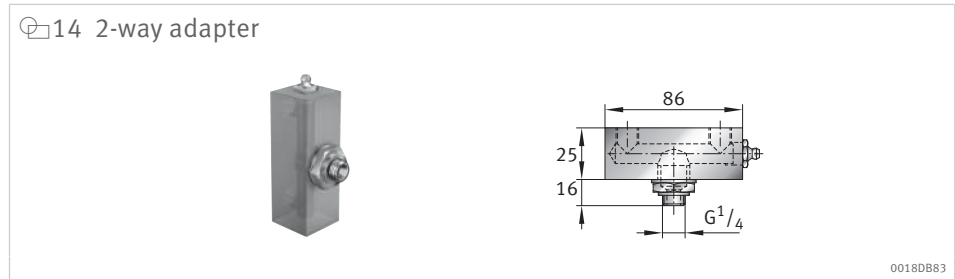

15 2-way adapter

Type	Ordering number	Ordering designation
2-way adapter	095285326-0000-10	ARCALUB-C1.ADAPTER-TWIN

2.1.3.4 Protective accessories for CONCEPT1

To protect the CONCEPT1 lubricator from falling parts or shocks, a protective cover can be fitted on the mounting support.



16 Protective accessories

Type	Ordering number	Ordering designation
Protective cover for lubricator	095285717-0000-10	ARCALUB-C1.COVER

## 3 Electromechanical lubricators

### 3.1 CONCEPT2

These lubricators to protection class IP54 offer, with their 2 outlets, a high degree of flexibility for the supply of grease or oil as a lubricant.

16 CONCEPT2-...-24VDC with multi-function interface

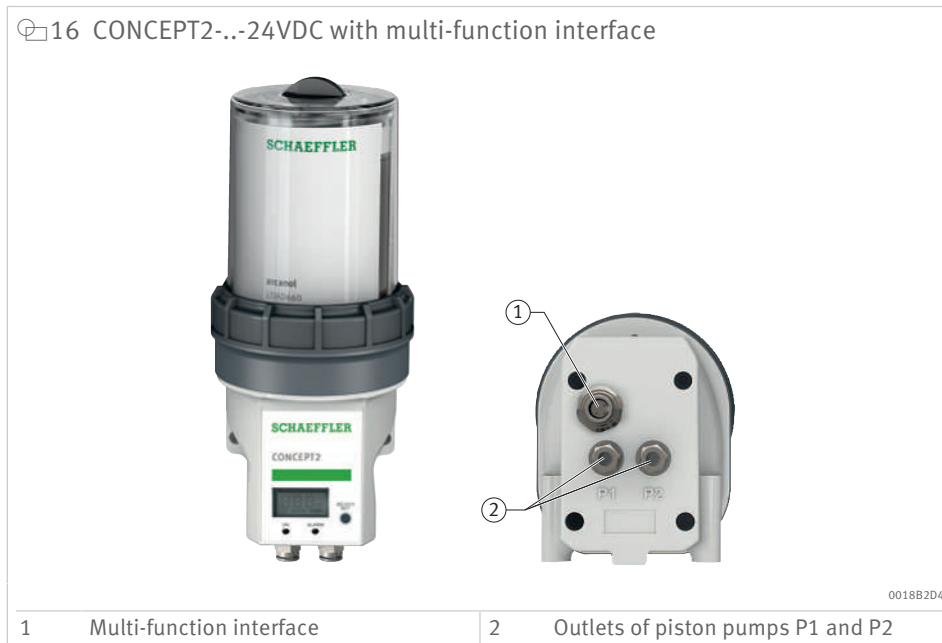

17 Overview of device types CONCEPT2

Lubricant	Number of pump bodies	Number of outlets	Ordering number	Ordering designation
Grease	2	2	086872931-0000-10	ARCALUB-C2-2P
	2	2	086873105-0000-10	ARCALUB-C2-2P-24VDC
Oil	2	2	092246265-0000-10	ARCALUB-C2-2P-OIL-24VDC

#### Advantages of the CONCEPT2 lubricator

- automatic lubricator for grease and oil (Arcanol range, other lubricants by agreement)
- easy to use and intuitive programming via LCD display in control panel
- flexible: filled cartridges containing Arcanol lubricants from Schaeffler or unfilled cartridges for customers to fill with other lubricants
- sustainable: the lubricators can be filled up to 3 times to help conserve the environment
- cost-effective: good/price performance ratio compared with other lubricators of the same device class
- 2 independently controllable special piston pumps (integrated back pressure monitoring) facilitate long lubrication lines
- lubrication intervals can either be controlled internally via an integrated timer or externally via PLC
- voltage supply either via battery or mains connection (DC 24 V)
- output of error messages via display, status LED and multi-function interface

18 Features of the device types

Features		ARCALUB-C2-		
		2P	2P-24VDC	2P-OIL-24VDC
Pump control	Internally by timer	•	•	•
	Externally via PLC	–	•	•
Grease (replaceable cartridge, 250 cm <sup>3</sup> )		•	•	–
Oil (built-in oil reservoir, 300 cm <sup>3</sup> )		–	–	•
Internal voltage supply, DC 3 V (battery)		•	–	–
External voltage supply, DC 24 V (multi-function interface)		–	•	•

3.1.1 Technical data

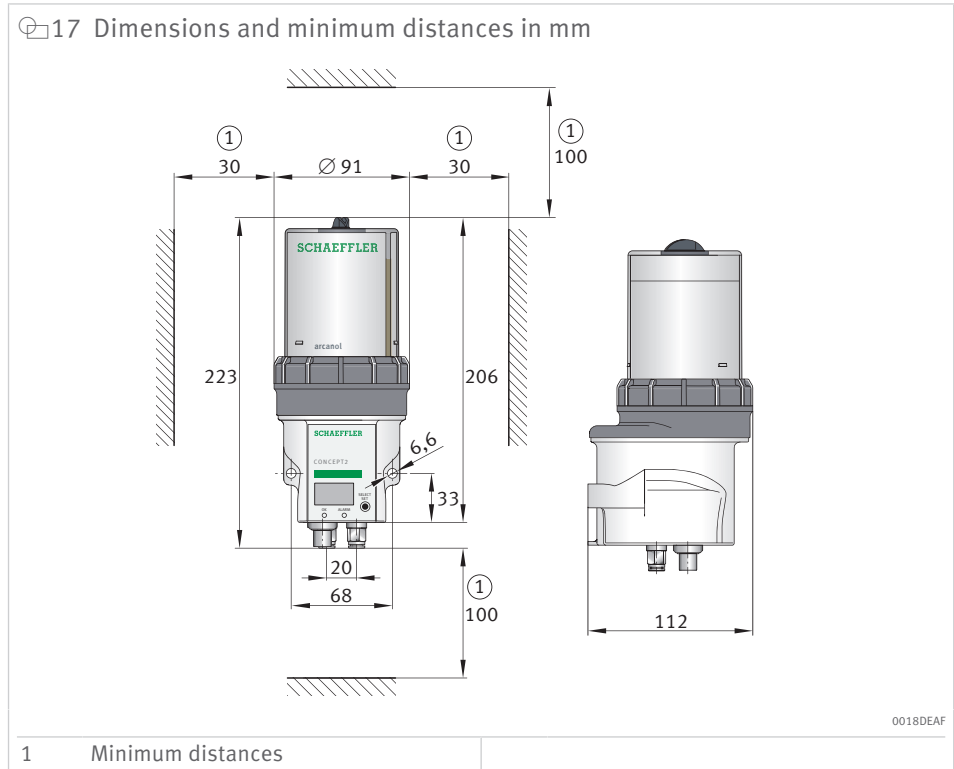

**!** Adherence to minimum distances is necessary for fitting and removing the cartridge and for accessibility to the hose connections.

 19 Technical data

Feature		Value
Dimensions		91 mm×223 mm×112 mm
Mass (without cartridge)		≈ 1 kg
Installation position		Vertical
Housing material		Polyamide
Protection class		IP54
Lubricant volume	Grease cartridge	250 cm <sup>3</sup>
	Oil	280 cm <sup>3</sup>
Lubricant	Grease	Grease up to NLGI 2 <sup>1)</sup>
	Oil	> 68 cSt
Functional principle		Piston pump
Operating pressure	DC 24 V	50 bar +7,5/-5 bar
	Battery	30 bar +4,5/-3 bar
Metering volume per outlet with one delivery stroke		0,16 cm <sup>3</sup> 0/-0,008 cm <sup>3</sup>
Number of pump bodies		2
Number of outlets		2
Outside diameter of the lubricant line		6 mm
Number of lubrication points	direct	≤ 2
	with splitters	≤ 4
	with progressive distributors <sup>2)</sup>	> 4
Connection		PA hose
Operating temperature		-20 °C up to +70 °C
Operating voltage		DC 24 V (±5 %) (stabilised) via cable 3-V lithium-metal battery
Multi-function interface	Function	Voltage supply, I/O interface
	Connection plug	M12×1, 4 pin (only for DC 24 V)
Current consumption	DC 24 V	I <sub>max</sub> ≤ 250 mA
Control of the lubrication intervals		Integrated time control by timer 25 min to 925 min External time control via multi-function interface (PLC)
Error output via display (error message with error code)		Empty, original cartridge missing, pump body motor too slow, internal electrical defect, back pressure too high
Status information via multi-function interface		Empty, collective error, signal for successfully completed lubrication cycle

1) Arcanol greases up to NLGI 2 (taking into account the maximum lubricant line length)  
Other greases up to NLGI 2 (with experimental determination of the maximum lubricant line length)  
No solid particles (except PTFE)

2) Technical clarification necessary

### 3.1.2 Connection options and ordering examples

18 Connection options CONCEPT2

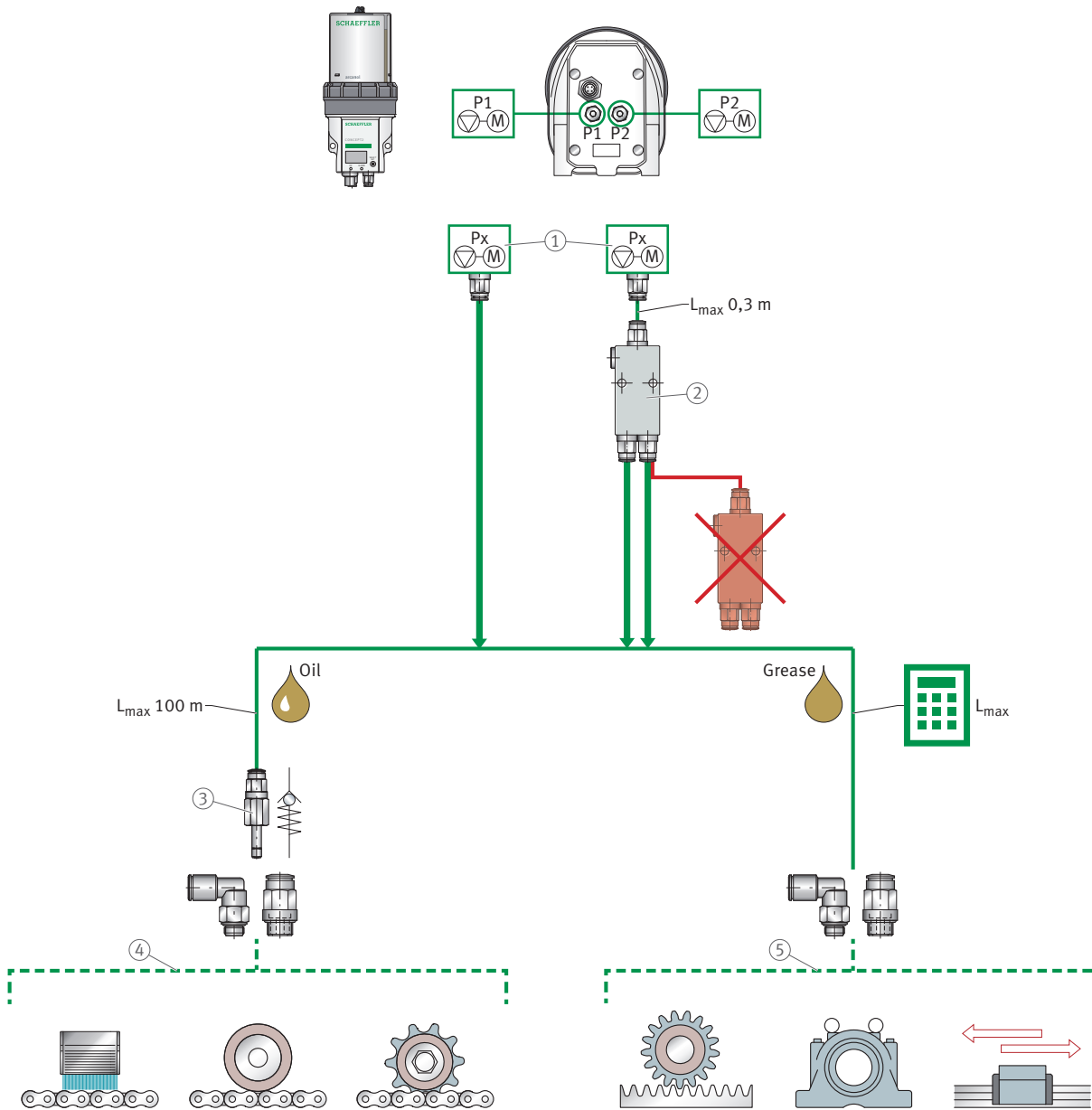

001A92AB

1	Individually programmable lubricant outlets	2	Splitter
3	Check valve	4	Oil lubrication of chains using brush or lubrication pinion
5	Grease lubrication of open gears, bearings or linear guidance systems		



When ordering, the components must be selected according to the application. The ordering designation and ordering number must be stated with each order.

An ordering example for a CONCEPT2 (battery version) lubricator, which is to be used to apply the lubricant Arcanol MULTITOP over a line length of 2 m, can be found below. The connection point in the application has 2 lubrication points with internal thread M8.

19 Ordering example



00180CFD

1	CONCEPT2	2	Battery
3	Hose	4	Hose connector parts
5	Grease cartridge	6	Hose cutter
7	Grease cartridge for lever grease gun (for prefilling the lubricant lines)	8	Hose connector part (for connecting hand-lever press and hose)

20 Ordering example

Item	Quantity	Ordering number	Ordering designation
(1)	1	086872931-0000-10	ARCALUB-C2-2P
(2)	1	087314762-0000-10	ARCALUB-C2.BATTERY
(3)	1	076691497-0000-10	ARCALUB-X.HOSE-PA12-10M
(4)	2	079567428-0000-10	ARCALUB-X.TUBEFIT-M8X1-SAT086G
(5)	1	087328810-0000-10	ARCALUB-C2.LC250-MULTITOP
(6)	1	083788620-0000-10	ARCALUB-X.HOSE-CUTTOOL
(7)	1	019144016-0000-10	ARCANOL-MULTITOP-400G
(8)	1	084465905-0000-10	ARCALUB-X.TUBEFIT-G1/8-SAT186G

### 3.1.3 Type-specific accessories and spare parts

#### 3.1.3.1 Battery



Energy supply by a battery is only possible in the case of CONCEPT2.

#### 📊 21 Battery

Type	Ordering number	Ordering designation
Battery pack (DC 3 V)	087314762-0000-10	ARCALUB-C2.BATTERY

#### 3.1.3.2 Complete packages for electric motors

The complete package EKIT allows the rapid refitting of electric motors to the CONCEPT2 lubricator. In addition to the lubricator, it contains all the accessories required for mounting and installation. The EKIT thus facilitates simple conversion to fully automatic relubrication.



The voltage supply for the CONCEPT2 lubricator is either provided by battery or externally (DC 24 V, with mains connection cable).

#### 📊 22 Complete packages

Type	Ordering number	Ordering designation
CONCEPT2 EKIT (battery)	092662269-0000-10	ARCALUB-C2-2P-EKIT
CONCEPT2 EKIT (DC 24 V)	092662277-0000-10	ARCALUB-C2-2P-24VDC-EKIT

⚠ Grease cartridges must be ordered separately.

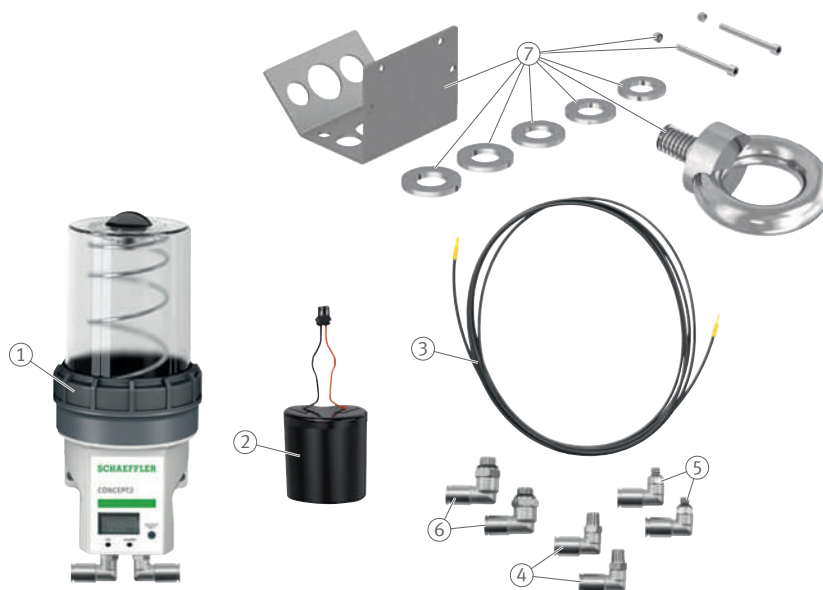
 22 CONCEPT2 EKIT (battery)

001A93E5

1	Lubricator	2	Battery
3	Hose	4	Hose connector part
5	Hose connector part	6	Hose connector part
7	Device holders		

 23 CONCEPT2 EKIT (battery)

Item	Quantity	Ordering number	Ordering designation
(1)	1	CONCEPT2 with angled lubricant outlets	
(2)	1	087314762-0000-10	ARCALUB-C2.BATTERY
(3)	1	Hose with outside diameter D = 6 mm, length L = 3 m	
(4)	2	076968553-0000-10	ARCALUB-X.TUBEFIT-M10X1-SAT106W
(5)	2	079567584-0000-10	ARCALUB-X.TUBEFIT-M8X1-SAT086W
(6)	2	084465964-0000-10	ARCALUB-X.TUBEFIT-G1/8-SAT186W
(7)	1	092435726-0000-10	ARCALUB-C2.HOLDER-KIT

📦 23 CONCEPT2 EKIT (DC 24 V)

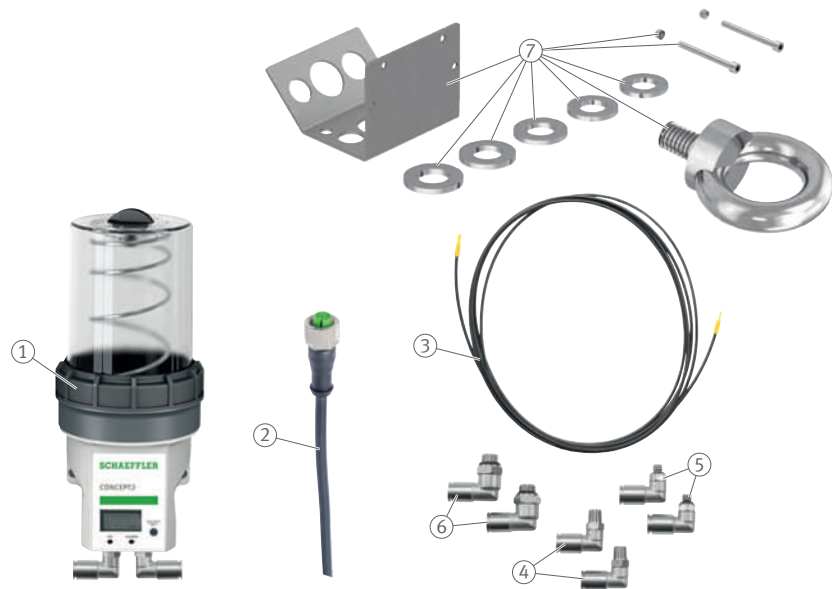

001A940C

1	Lubricator	2	Connection cable
3	Hose	4	Hose connector part
5	Hose connector part	6	Hose connector part
7	Device holders		

📦 24 CONCEPT2 EKIT (DC 24 V)

Item	Quantity	Ordering number	Ordering designation
(1)	1	CONCEPT2 with angled lubricant outlets	
(2)	1	075378361-0000-10	ARCALUB-X.CABLE-M12-10M
(3)	1	Hose with outside diameter D = 6 mm, length L = 3 m	
(4)	2	076968553-0000-10	ARCALUB-X.TUBEFIT-M10X1-SAT106W
(5)	2	079567584-0000-10	ARCALUB-X.TUBEFIT-M8X1-SAT086W
(6)	2	084465964-0000-10	ARCALUB-X.TUBEFIT-G1/8-SAT186W
(7)	1	092435726-0000-10	ARCALUB-C2.HOLDER-KIT

## 3.2 CONCEPT4

These lubricators to protection class IP54 offer, with their 2 pump bodies, a high degree of flexibility for the supply of grease as a lubricant.

📐 24 CONCEPT4 with multi-function interface



0016EFDD

1	Multi-function interface	2	Outlets of piston pumps P1 and P2
---	--------------------------	---	-----------------------------------

📐 25 Overview of device types CONCEPT4

Lubricant	Number of pump bodies	Number of outlets	Ordering number	Ordering designation
Grease	2	4	094901589-0000-10	ARCALUB-C4-2P-24VDC

### Advantages of the CONCEPT4 lubricator

- automatic lubricator for grease (Arcanol range, other lubricants by agreement)
- flexible: filled cartridges containing Arcanol lubricants from Schaeffler or unfilled cartridges for customers to fill with other lubricants
- sustainable: the lubricators can be filled up to 3 times to help conserve the environment
- cost-effective: good/price performance ratio compared with other lubricators of the same device class
- 2 independently controllable special piston pumps (integrated back pressure monitoring) facilitate long lubrication lines
- control of the lubrication intervals via PLC
- output of error messages via multi-function interface

**!** The lubricator has no operating unit or display that could be used for programming and status display. As a result, the lubricator must always be integrated into an external controller (PLC) for operation.

### 3.2.1 Technical data

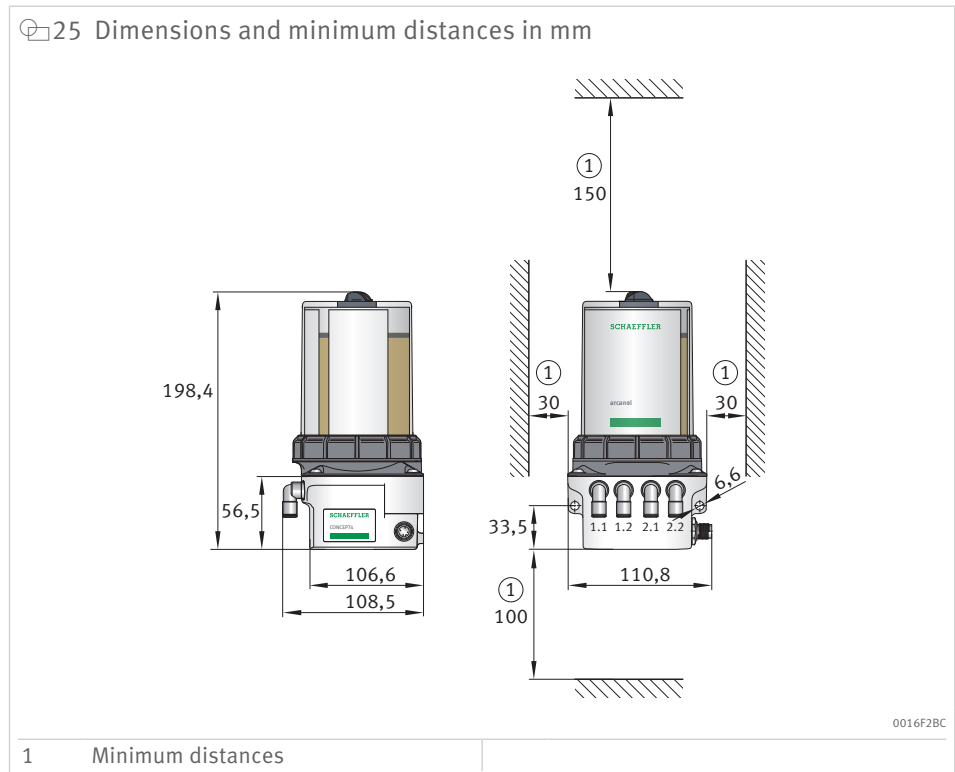

**!** Adherence to minimum distances is necessary for fitting and removing the cartridge and for accessibility to the hose connections.

 26 Technical data

Feature		Value
Dimensions		108,5 mm×198,4 mm×110,8 mm
Mass (without cartridge)		≈ 1,3 kg
Installation position		Vertical
Housing material		Die-cast zinc, PA66-GF30, POM
Protection class		IP54
Lubricant volume (grease cartridge)		400 cm <sup>3</sup>
Lubricant		Grease up to NLGI 2 <sup>1)</sup>
Functional principle		Piston pump
Operating pressure		70 bar +7/-10,5 bar
Metering volume per outlet with one delivery stroke		0,16 cm <sup>3</sup> 0/-0,008 cm <sup>3</sup>
Number of pump bodies		2
Number of outlets		4
Outside diameter of the lubricant line		8 mm
Number of lubrication points	direct	≤ 4
	with splitters	≤ 8
	with progressive distributors <sup>2)</sup>	> 12
Connection		PA hose
Operating temperature		-15 °C up to +60 °C
Operating voltage (stabilised)		DC 24 V (±5 %)
Multi-function interface	Function	Voltage supply, I/O interface
	Connection plug	M12×1, 4 pin (only for DC 24 V)
Current consumption	DC 24 V	I <sub>max</sub> ≤ 350 mA
Control of the lubrication intervals		External time control via multi-function interface (PLC)
Status information via multi-function interface		Advance fill level warning, empty, collective error, signal for successfully completed lubrication cycle

- 1) Arcanol greases up to NLGI 3 (taking into account the maximum lubricant line length).  
Other greases up to NLGI 2 (with experimental determination of the maximum lubricant line length).  
No solid particles (except PTFE).
- 2) Technical clarification necessary

### 3.2.2 Connection options and ordering examples

26 Connection options CONCEPT4

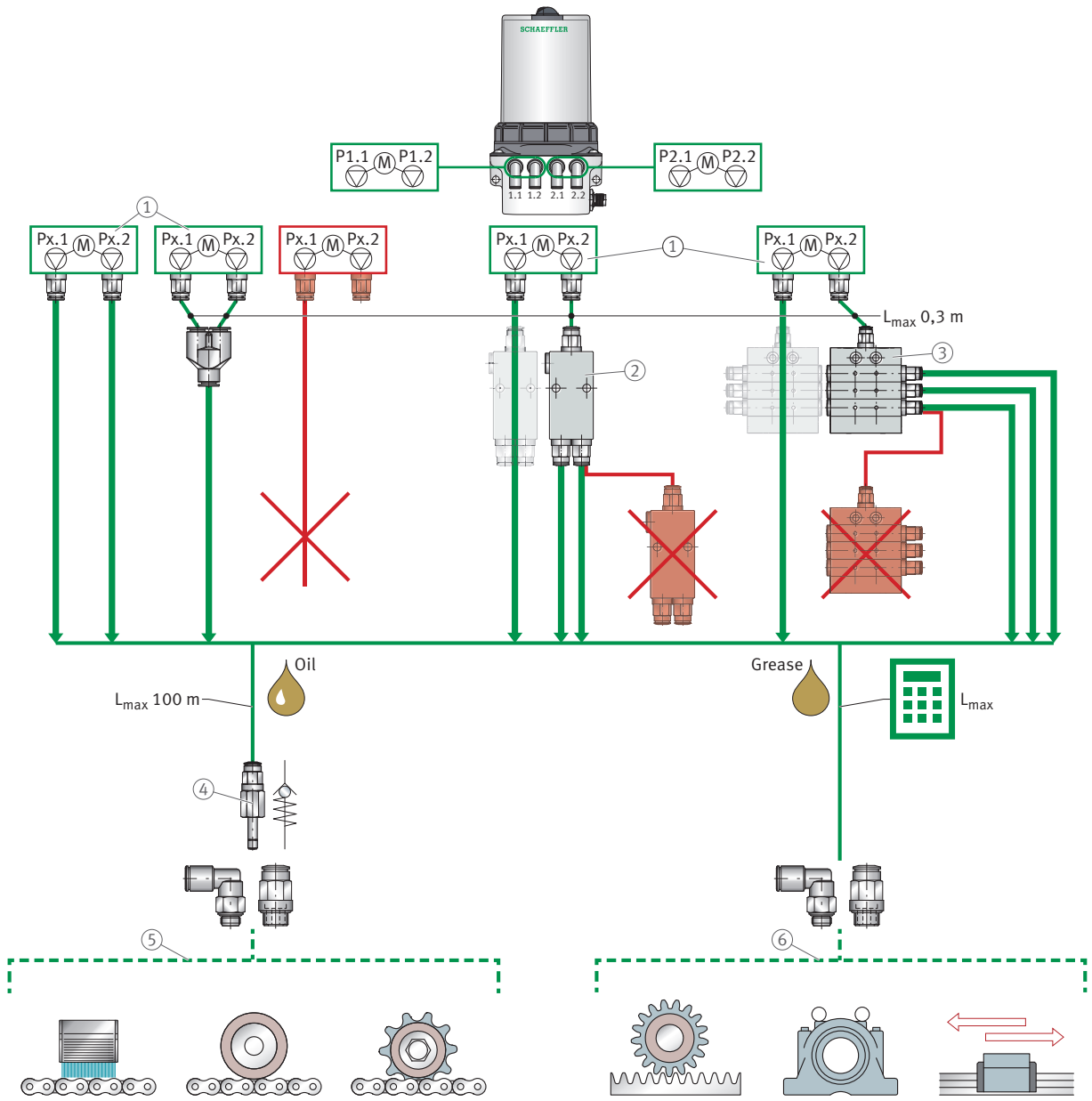

001AA85B

1	Individually programmable lubricant outlets	2	Splitter
3	Progressive distributors	4	Check valve
5	Oil lubrication of chains using brush or lubrication pinion	6	Grease lubrication of open gears, bearings or linear guidance systems



When ordering, the components must be selected according to the application. The ordering designation and ordering number must be stated with each order.

An ordering example for a CONCEPT4 lubricator, which is to be used to apply the lubricant Arcanol MULTITOP over a line length of 2 m, can be found below. The connection point in the application has 4 lubrication points with internal thread M8.

🔗 27 Ordering example



00194E82

📊 27 Ordering example

Item	Quantity	Ordering number	Ordering designation
(1)	1	094901589-0000-10	ARCALUB-C4-2P-24VDC
(2)	1	075378361-0000-10	ARCALUB-X.CABLE-M12-10M
(3)	1	083788603-0000-10	ARCALUB-X.HOSE-PA66-50M
(4)	4	083654216-0000-10	ARCALUB-X.TUBEFIT-M8X1-SAT088G
(5)	1	095056777-0000-10	ARCALUB-C4.LC400-MULTITOP
(6)	1	083788620-0000-10	ARCALUB-X.HOSE-CUTTOOL
(7)	1	019144016-0000-10	ARCANOL-MULTITOP-400G
(8)	1	083654534-0000-10	ARCALUB-X.TUBEFIT-G1/8-SAT188G

### 3.3 CONCEPT8

These lubricators to protection class IP65 offer, with their 2 or 4 pump bodies, a high degree of flexibility for the supply of grease or oil as a lubricant.

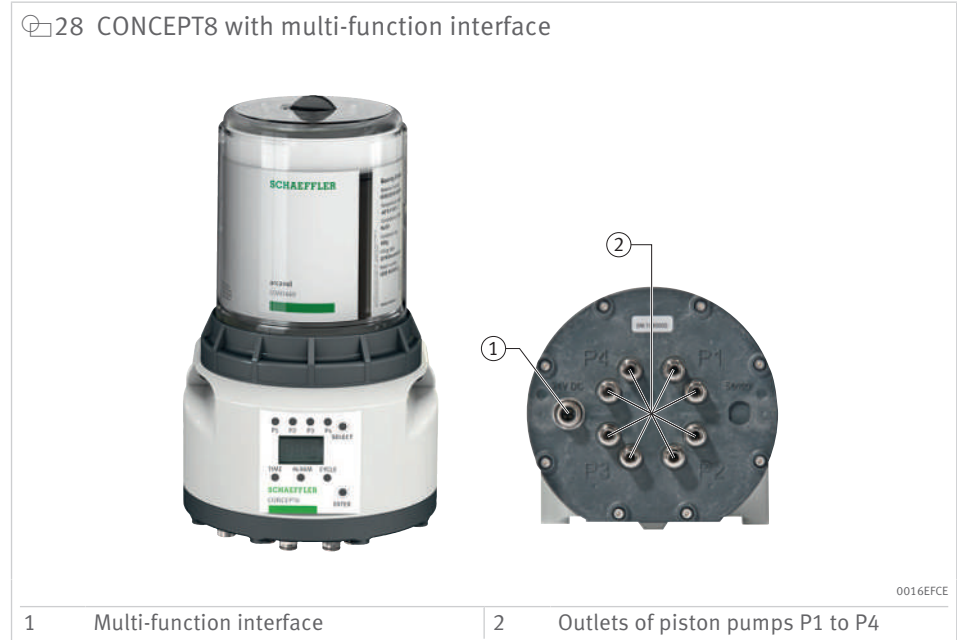

28 Overview of device types CONCEPT8

Lubricant	Number of pump bodies	Number of outlets <sup>1)</sup>	Ordering number	Ordering designation
Grease	2	4	082249156-0000-10	ARCALUB-C8-2P
	4	8	082266646-0000-10	ARCALUB-C8-4P
Oil	2	4	083786910-0000-10	ARCALUB-C8-2P-OIL
	4	8	083787062-0000-10	ARCALUB-C8-4P-OIL

<sup>1)</sup> Adjustment by deactivation of pump bodies and by combination or splitting of outlets.

#### Advantages of the CONCEPT8 lubricator

- automatic lubricator for grease and oil (Arcanol range, other lubricants by agreement)
- easy to use and intuitive programming via LCD display in control panel
- flexible: filled cartridges containing Arcanol lubricants from Schaeffler or unfilled cartridges for customers to fill with other lubricants
- sustainable: the lubricators can be filled up to 3 times to help conserve the environment
- cost-effective: good/price performance ratio compared with other lubricators of the same device class
- lubrication intervals can either be controlled internally via an integrated timer or externally via PLC
- output of error messages via display, status LED and multi-function interface

## 3.3.1 Technical data

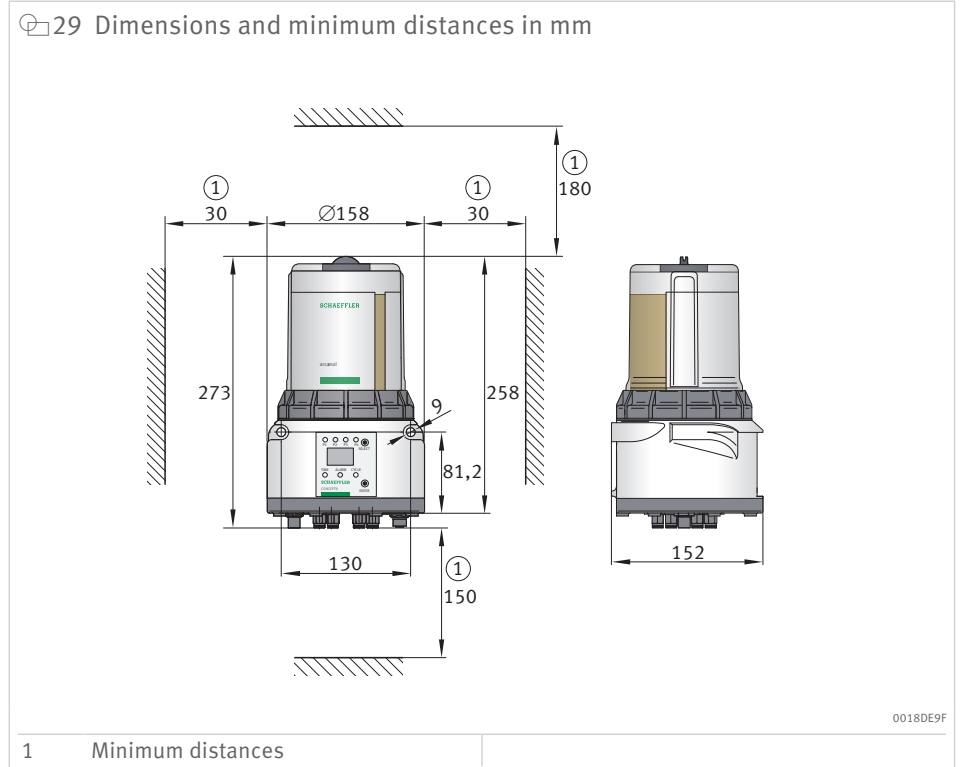

- !** Adherence to minimum distances is necessary for fitting and removing the cartridge and for accessibility to the hose connections.

 29 Technical data

Feature		Value
Dimensions		158 mm×273 mm×152 mm
Mass (without cartridge)		≈ 3 kg
Installation position		Vertical
Housing material		Aluminium (powder coated), polyamide
Protection class		IP65
Lubricant volume	Grease cartridge	800 cm <sup>3</sup>
	Oil	1000 cm <sup>3</sup>
Lubricant	Grease	Grease up to NLGI 2 <sup>1)</sup>
	Oil	> 68 cSt
Functional principle		Piston pump
Operating pressure		70 bar +7/-10,5 bar
Metering volume per outlet with one delivery stroke		0,16 cm <sup>3</sup> 0/-0,008 cm <sup>3</sup>
Number of outlets		max. 8
Outside diameter of the lubricant line	Grease	8 mm
	Oil	6 mm
Number of lubrication points	direct	≤ 8
	with splitters	≤ 16
	with progressive distributors <sup>2)</sup>	> 16
Connection		PA hose
Operating temperature		-20 °C up to +70 °C
Operating voltage (stabilised)		DC 24 V (±5 %)
Multi-function interface	Function	Voltage supply, I/O interface
	Connection plug	M12×1, 4 pin (only for DC 24 V)
Current consumption	DC 24 V	I <sub>max</sub> ≤ 350 mA
Control of the lubrication intervals		Integrated time control by timer 1 h to 240 h External time control via multi-function interface (PLC)
Error output via display (error message with error code)		Empty, original cartridge missing, pump body motor too slow, internal electrical defect, back pressure too high
Status information via multi-function interface		Empty, collective error, signal for successfully completed lubrication cycle

<sup>1)</sup> Arcanol greases up to NLGI 3 (taking into account the maximum lubricant line length).  
Other greases up to NLGI 2 (with experimental determination of the maximum lubricant line length).  
No solid particles (except PTFE).

<sup>2)</sup> Technical clarification necessary

### 3.3.2 Connection options and ordering examples

30 Connection options CONCEPT8

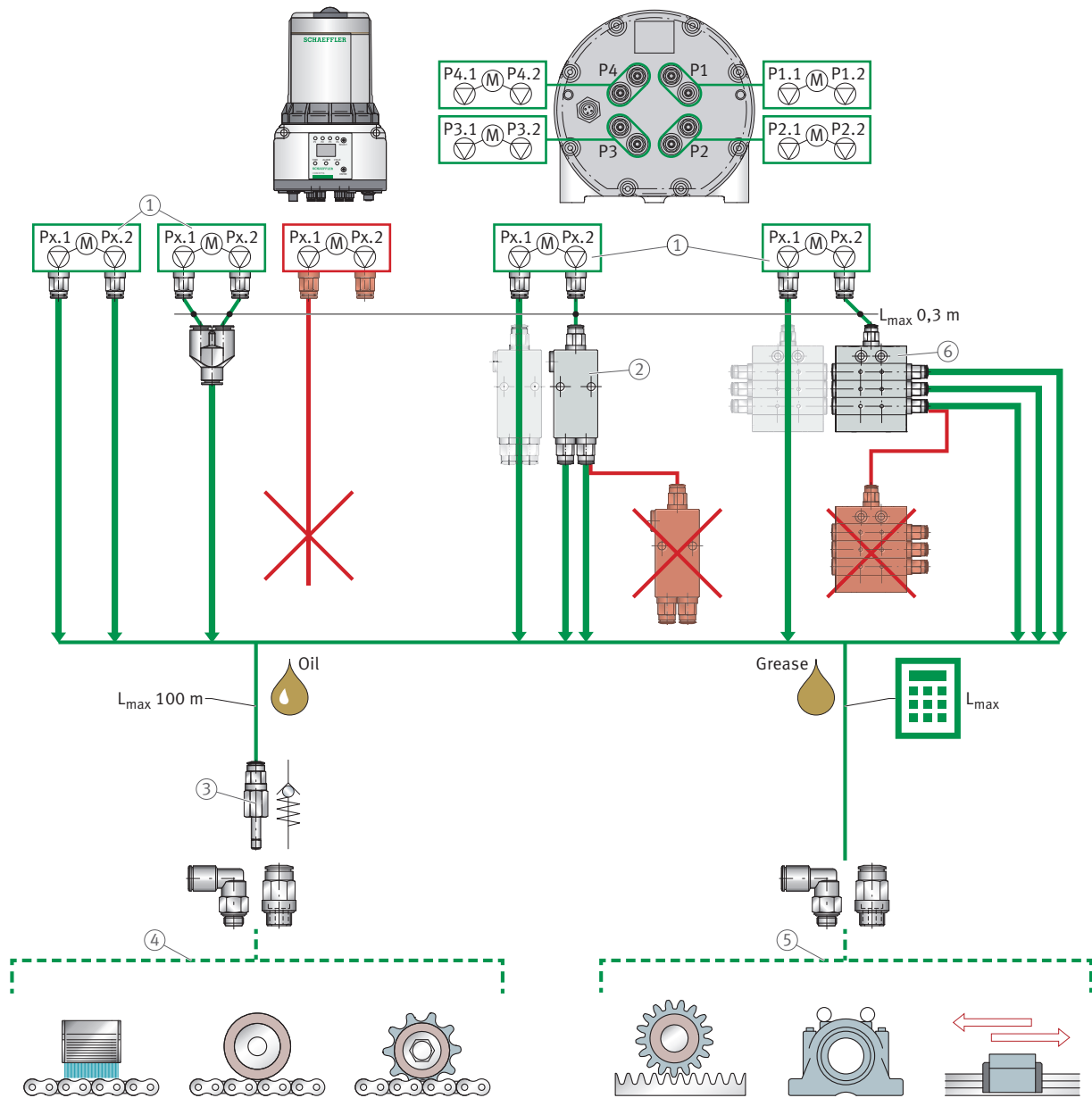

001AA884

1	Individually programmable lubricant outlets	2	Splitter
3	Check valve	4	Oil lubrication of chains using brush or lubrication pinion
5	Grease lubrication of open gears, bearings or linear guidance systems	6	Progressive distributors

When ordering, the components must be selected according to the application. The ordering designation and ordering number must be stated with each order. An ordering example for a CONCEPT8 lubricator, which is to be used to apply the lubricant Arcanol MULTITOP over a line length of 50 m, can be found below. The connection point in the application has 8 lubrication points with internal thread M8.

31 Ordering example



1	CONCEPT8	2	Connection cable with plug
3	Hose	4	Hose connector parts
5	Grease cartridge	6	Hose cutter
7	Grease cartridge for lever grease gun (for prefilling the lubricant lines)	8	Hose connector part (for connecting hand-lever press and hose)

30 Ordering example

Item	Quantity	Ordering number	Ordering designation
(1)	1	082266646-0000-10	ARCALUB-C8-4P
(2)	1	075378361-0000-10	ARCALUB-X.CABLE-M12-10M
(3)	1	083788603-0000-10	ARCALUB-X.HOSE-PA66-50M
(4)	8	083654216-0000-10	ARCALUB-X.TUBEFIT-M8X1-SAT088G
(5)	1	082631492-0000-10	ARCALUB-C8.LC800-MULTITOP
(6)	1	083788620-0000-10	ARCALUB-X.HOSE-CUTTOOL
(7)	1	019144016-0000-10	ARCANOL-MULTITOP-400G
(8)	1	083654534-0000-10	ARCALUB-X.TUBEFIT-G1/8-SAT188G

### 3.3.3 Type-specific accessories and spare parts

#### 3.3.3.1 Seal kit

The seal kit is solely intended for replacing the seals in the automatic CONCEPT8 lubricators.

32 Installation positions of the components of the seal kit for CONCEPT8



0018CAEB

1	Axial housing seal	2	Grub screw M3×4
3	O-ring 37,5×3		

31 Seal kit

Type	Ordering number	Ordering designation
CONCEPT8	094977291-0000-10	ARCALUB-C8.SEAL-KIT

## 4 OPTIME lubricators

### 4.1 OPTIME C1

OPTIME C1 is an easy to use and economical solution for automatic single point lubrication. OPTIME C1 represents a further expansion of the Schaeffler OPTIME system developed for the condition monitoring of rolling bearings and integrates the lubricators of series CONCEPT1.

During the development of the system, particular attention was paid to the very simple commissioning process, smooth expandability and wide range of possible uses. Every single process step was designed to be as user-friendly as possible. As a result of these characteristics, Schaeffler OPTIME is particularly suitable for the automated and economical monitoring and lubrication of a large number of machines.

#### Digital Service

The overall solution is a combination of hardware (lubricator, cartridge) and software (Digital Service). The software can be accessed using the Digital Service Tenant, enabling the user to display the current status of the lubricator (for example, the fill level of the cartridge, blocked lubricant line) on a mobile device or in a browser. The software allows optimum planning of maintenance activities and helps to prevent failures due to defective lubrication.



📊 32 Overview of OPTIME C1 products

Type	Quantity <sup>1)</sup>	Ordering number	Ordering designation
OPTIME C1 Region 1 <sup>2)</sup>	10	300040903-0000-10	OPTIME-LW-C1-R1#N10
OPTIME C1 Region 3 <sup>3)</sup>	10	300042426-0000-10	OPTIME-LW-C1-R3#N10
Digital Service	–	096927089-0000	OPTIME-DIGSERV-LUB
Digital Service Tenant	–	095259724-0000	OPTIME-DIGSERV-BASEFEE

<sup>1)</sup> Quantity per packaging unit

<sup>2)</sup> EU, Israel, Republic of Macedonia, Norway, Saudi Arabia, Switzerland, Turkey, Great Britain, Australia, India, Indonesia, Japan, Malaysia, New Zealand, Philippines, Singapore, Thailand, Vietnam, Canada, Colombia, Peru, USA

<sup>3)</sup> EU, Israel, Republic of Macedonia, Norway, Morocco, Serbia, Saudi Arabia, United Arab Emirates, South Africa, Switzerland, Turkey, Great Britain, Australia, China, India, Indonesia, South Korea, Taiwan, Japan, Malaysia, New Zealand, Philippines, Singapore, Thailand, Vietnam, Canada, Brazil, Colombia, Peru, Mexico, Chile, USA



### Advantages of OPTIME C1

- status of the lubrication devices can be checked at any time and from anywhere
- economical and reliable relubrication
- reliable lubrication reduces the number of failures and downtimes
- hidden costs are avoided, as regular maintenance and inspection rounds are no longer required
- extended bearing life as a result of optimised and controlled lubrication
- guided and simple installation, commissioning and maintenance

### Product features of OPTIME C1

- status information and fill level information at a glance
- automatic alarm activation in the event of unusual operating conditions such as excessive back pressure, for example
- simple commissioning and adjustment of the settings for each lubricator
- optimised maintenance and routing
- pressure build-up to 10 bar
- rapid cartridge replacement possible, as the cartridge is screwed directly onto the OPTIME C1
- user guidance in several languages

### Scope of delivery

A delivery of OPTIME C1 lubricators contains 10× OPTIME C1, 10× battery pack, 1× filling nipple OPTIME-LW-C1.NIPPLE-PREFILL-R1/4 and 1× Quick Start Guide.



The CONCEPT1 lubricator is used by the OPTIME C1 as a grease cartridge and can be purchased separately ►10|2.1.

### 4.1.1 Technical data

34 OPTIME C1 and lubricator CONCEPT1 (60 cm<sup>3</sup> and 125 cm<sup>3</sup>)

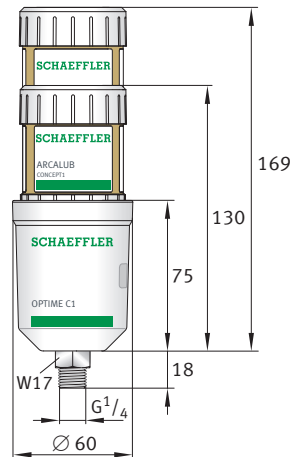

00198AA9

33 Technical data

Feature	Value	
Dimensions	60 mm×93 mm×60 mm	
Drive system	Electromechanical	
Mass	≈ 0,25 kg	
Installation position	As required	
Housing material	PET	
Protection class	IP68 (in conjunction with CONCEPT1)	
Operating pressure	≤ 10 bar	
Metering volume per lubrication interval	≈ 0,5 cm <sup>3</sup>	
Metering volume per day (dependent on size and setting of CONCEPT1)	0,17 cm <sup>3</sup> up to 8,3 cm <sup>3</sup>	
Commissioning	NFC	
Cartridge CONCEPT1	Dispensing time (steplessly adjustable)	1 up to 12 months
	Lubricant volume	60 cm <sup>3</sup> or 125 cm <sup>3</sup>
	Grease	Arcanol range up to NLGI 2 Other greases by agreement
	Oil	> 68 cSt at 40 °C
Wirepas Mesh (ISM Band)	2,4 GHz	
Line of sight range	100 m	
Voltage supply (battery pack)	6 V	
	2,3 Ah	
Threaded connector	G 1/4"	
Operating temperature	-10 °C to +55 °C	
Storage	Location	Protect from direct sunlight, store in a dry place
	Temperature	+20±5 °C
	Humidity	≤ 65 %

### Certifications



The OPTIME C1 lubricator is certified by law in numerous countries. Detailed certification information can be found online at <https://www.schaeffler.de/std/1FC3>

## 4.1.2 Connection options and ordering examples

## 35 Connection options OPTIME C1 with CONCEPT1

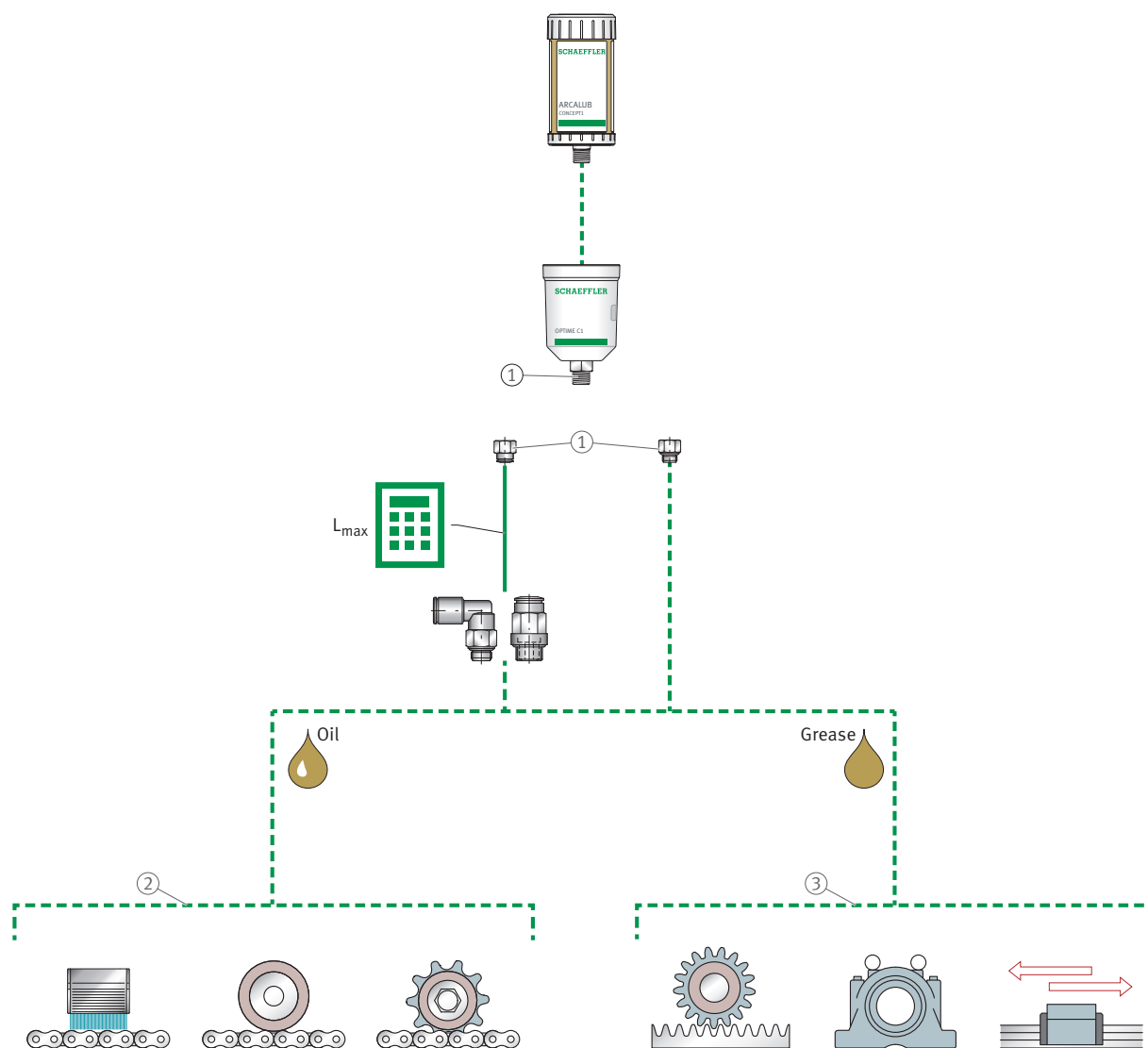

001AA82B

1	Individually programmable lubricant outlet	2	Oil lubrication of chains using brush or lubrication pinion
3	Grease lubrication of open gears, bearings or linear guidance systems		

When ordering, the components must be selected according to the application. The ordering designation and ordering number must be stated with each order.

36 Location method OPTIME C1 with ARCALUB-C1-125



001A9304

1	Fixing bracket	2	Cartridge ARCALUB-C1-125
3	OPTIME C1	4	Fixing nipple
5	Hose connector part	6	Hose

37 Mounting examples OPTIME C1

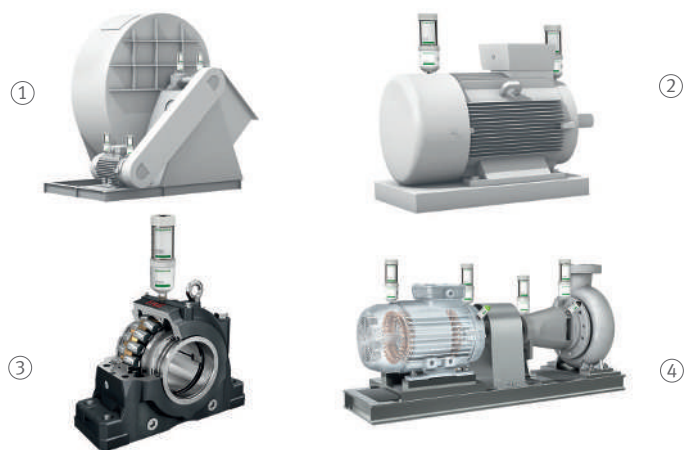

001A8F48

1	Fan	2	Electric motor
3	Plummer block housing	4	Pump drivetrain with electric motor

### 4.1.3 Type-specific accessories and spare parts

#### 4.1.3.1 Battery pack and filling nipple

38 Battery pack and filling nipple

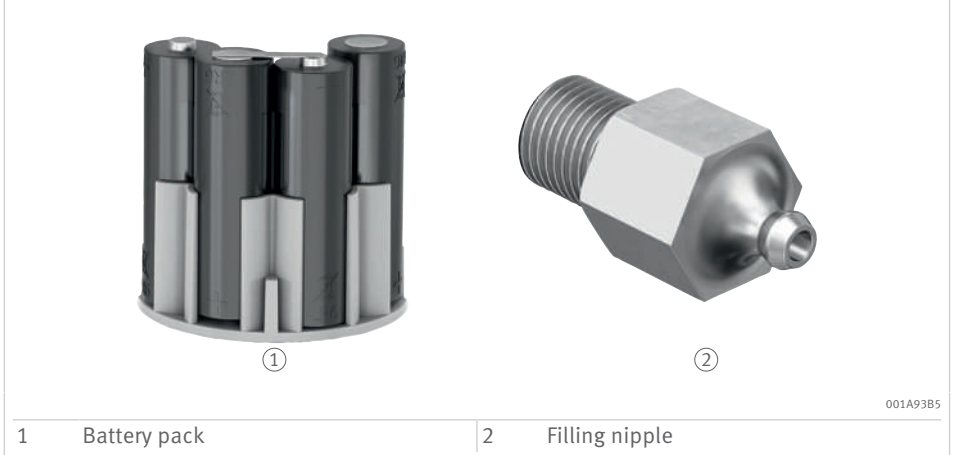

1 Battery pack

2 Filling nipple

34 Type-specific accessories OPTIME C1

Description	Quantity <sup>1)</sup>	Ordering number	Ordering designation
Battery pack	10	096687606-0000-10	OPTIME-LW-C1.BATTERY#N10
Filling nipple	3	096691611-0000-10	OPTIME-LW-C1.NIPPLE-PREFILL-R1/4

<sup>1)</sup> Quantity per packaging unit

4.1.3.2 Cartridge adapter

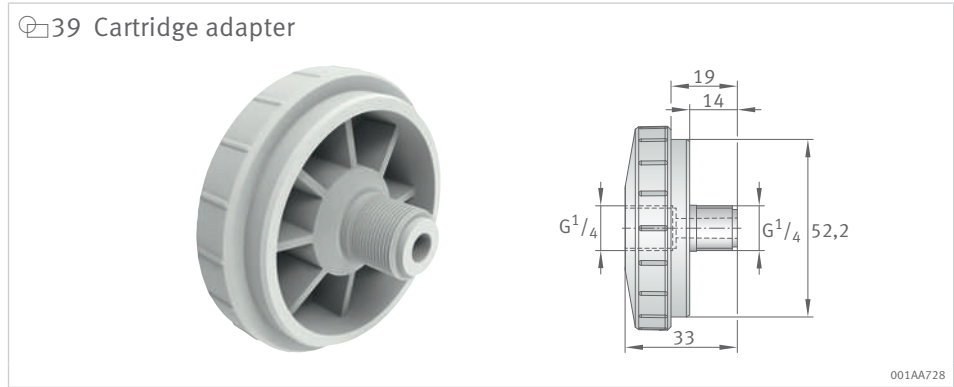

The OPTIME C1 cartridge adapter makes it possible to use compatible cartridges from other providers, thus allowing the user to make use of the advantages of the OPTIME C1 lubricator and integrate third-party cartridges without having to switch from the existing cartridge provider.

The cartridge adapter is screwed onto the OPTIME C1 in place of the cartridge when setting up the OPTIME C1. The third-party cartridge is then screwed onto the cartridge adapter. The cartridge size and lubricant must be selected manually in the app.

35 Cartridge adapter

Description	Quantity <sup>1)</sup>	Ordering number	Ordering designation
Cartridge adapter	10	301271968-0000-10	OPTIME-LW-C1.ADAPTER#N10

<sup>1)</sup> Quantity per packaging unit

36 Permissible cartridges from alternative providers (60 cm<sup>3</sup> and 125 cm<sup>3</sup>)

Cartridge provider	Products
perma	FLEX, FLEX PLUS, NOVA
SKF	System 24 LAGD
NTN	READY BOOSTER, SMART BOOSTER
Klüber	KlübermaticFLEX, KlübermaticNOVA
simalube	Cartridges can be used without cartridge adapter

## 5 Cartridges

### 5.1 Filled cartridges

**!** For the OPTIME C1 lubrication system, the CONCEPT1 lubricators are used as cartridges ►10|2.1.

 40 Grease cartridge for CONCEPT2



 37 Grease cartridges for CONCEPT2, filling volume 250 cm<sup>3</sup>

Lubricant	Ordering number	Ordering designation
Arcanol CLEAN-M	087334194-0000-10	ARCALUB-C2.LC250-CLEAN-M
Arcanol FOOD2	087334020-0000-10	ARCALUB-C2.LC250-FOOD2
Arcanol LOAD150	087329077-0000-10	ARCALUB-C2.LC250-LOAD150
Arcanol LOAD220	087329115-0000-10	ARCALUB-C2.LC250-LOAD220
Arcanol LOAD400	087329131-0000-10	ARCALUB-C2.LC250-LOAD400
Arcanol LOAD460	087329140-0000-10	ARCALUB-C2.LC250-LOAD460
Arcanol LOAD1000	087329280-0000-10	ARCALUB-C2.LC250-LOAD1000
Arcanol MULTI2	087328038-0000-10	ARCALUB-C2.LC250-MULTI2
Arcanol MULTITOP	087328810-0000-10	ARCALUB-C2.LC250-MULTITOP
Arcanol MOTION2	087334216-0000-10	ARCALUB-C2.LC250-MOTION2
Arcanol SEMIFLUID	095195831-0000-10	ARCALUB-C2.LC250-SEMIFLUID
Arcanol SPEED2,6	087334046-0000-10	ARCALUB-C2.LC250-SPEED2,6
Arcanol TEMP90	087329816-0000-10	ARCALUB-C2.LC250-TEMP90
Arcanol TEMP110	087329840-0000-10	ARCALUB-C2.LC250-TEMP110
Arcanol TEMP120	087329980-0000-10	ARCALUB-C2.LC250-TEMP120
Arcanol TEMP200	087329999-0000-10	ARCALUB-C2.LC250-TEMP200

41 Grease cartridge for CONCEPT4



0016E9FB

38 Grease cartridges for CONCEPT4, filling volume 400 cm<sup>3</sup>

Lubricant	Ordering number	Ordering designation
Arcanol CLEAN-M	095058125-0000-10	ARCALUB-C4.LC400-CLEAN-M
Arcanol EM-L038	095058141-0000-10	ARCALUB-C4.LC400-EM-L038
Arcanol FOOD2	095058117-0000-10	ARCALUB-C4.LC400-FOOD2
Arcanol LOAD150	095056785-0000-10	ARCALUB-C4.LC400-LOAD150
Arcanol LOAD220	095056793-0000-10	ARCALUB-C4.LC400-LOAD220
Arcanol LOAD400	095056807-0000-10	ARCALUB-C4.LC400-LOAD400
Arcanol LOAD460	095058010-0000-10	ARCALUB-C4.LC400-LOAD460
Arcanol LOAD1000	095058028-0000-10	ARCALUB-C4.LC400-LOAD1000
Arcanol MULTI2	095056769-0000-10	ARCALUB-C4.LC400-MULTI2
Arcanol MULTI3	095056750-0000-10	ARCALUB-C4.LC400-MULTI3
Arcanol MULTITOP	095056777-0000-10	ARCALUB-C4.LC400-MULTITOP
Arcanol MOTION2	095058133-0000-10	ARCALUB-C4.LC400-MOTION2
Arcanol SEMIFLUID	095195823-0000-10	ARCALUB-C4.LC400-SEMIFLUID
Arcanol SPEED2,6	095058087-0000-10	ARCALUB-C4.LC400-SPEED2,6
Arcanol TEMP90	095058044-0000-10	ARCALUB-C4.LC400-TEMP90
Arcanol TEMP110	095058052-0000-10	ARCALUB-C4.LC400-TEMP110
Arcanol TEMP120	095058060-0000-10	ARCALUB-C4.LC400-TEMP120
Arcanol TEMP200	095058079-0000-10	ARCALUB-C4.LC400-TEMP200
Arcanol VIB3	095058095-0000-10	ARCALUB-C4.LC400-VIB3



42 Grease cartridge for CONCEPT8



0016EFEC

39 Grease cartridges for CONCEPT8, filling volume 800 cm<sup>3</sup>

Lubricant	Ordering number	Ordering designation
Arcanol CLEAN-M	083549129-0000-10	ARCALUB-C8.LC800-CLEAN-M
Arcanol FOOD2	083549064-0000-10	ARCALUB-C8.LC800-FOOD2
Arcanol LOAD150	083532439-0000-10	ARCALUB-C8.LC800-LOAD150
Arcanol LOAD220	083533583-0000-10	ARCALUB-C8.LC800-LOAD220
Arcanol LOAD400	083533761-0000-10	ARCALUB-C8.LC800-LOAD400
Arcanol LOAD460	083533818-0000-10	ARCALUB-C8.LC800-LOAD460
Arcanol LOAD1000	083548343-0000-10	ARCALUB-C8.LC800-LOAD1000
Arcanol MULTI2	083532412-0000-10	ARCALUB-C8.LC800-MULTI2
Arcanol MULTI2	083548289-0000-10	ARCALUB-C8.LC800-MULTI3
Arcanol MULTITOP	082631492-0000-10	ARCALUB-C8.LC800-MULTITOP
Arcanol SEMIFLUID	095195815-0000-10	ARCALUB-C8.LC800-SEMIFLUID
Arcanol SPEED2,6	083548629-0000-10	ARCALUB-C8.LC800-SPEED2,6
Arcanol TEMP90	083533630-0000-10	ARCALUB-C8.LC800-TEMP90
Arcanol TEMP110	083548580-0000-10	ARCALUB-C8.LC800-TEMP110
Arcanol TEMP120	083548599-0000-10	ARCALUB-C8.LC800-TEMP120
Arcanol TEMP200	083548602-0000-10	ARCALUB-C8.LC800-TEMP200
Arcanol VIB3	083549099-0000-10	ARCALUB-C8.LC800-VIB3

## 5.2 Unfilled cartridges and accessories

Unfilled cartridges can be filled by the actual customer. This permits the additional flexible use of lubricators for other lubricants.

☐43 Unfilled grease cartridges

1	Unfilled grease cartridge including closing plug	2	Pack of spare closing plugs
3	Filling adapters	4	Drum pump ▶ 99

001A92D4

### ☐40 Unfilled grease cartridges (incl. closing plugs)

Type	Ordering number	Ordering designation
CONCEPT2 with 250 cm <sup>3</sup>	095028803-0000-10	ARCALUB-C2.LC250-REFILLABLE
CONCEPT4 with 400 cm <sup>3</sup>	095058036-0000-10	ARCALUB-C4.LC400-REFILLABLE
CONCEPT8 with 800 cm <sup>3</sup>	095028790-0000-10	ARCALUB-C8.LC800-REFILLABLE

The unfilled cartridges are supplied with a closing plug. The closing plugs can be reordered.

### ☐41 Closing plugs (spare pack)

Type	Quantity <sup>1)</sup>	Ordering number	Ordering designation
CONCEPT2	10	095179879-0000-10	ARCALUB-C2.LC250-SEAL-CAP
CONCEPT4	10	095179887-0000-10	ARCALUB-C4.LC400-SEAL-CAP
CONCEPT8	10	095179895-0000-10	ARCALUB-C8.LC800-SEAL-CAP

<sup>1)</sup> Quantity per packaging unit

The refillable cartridges can be filled directly from a drum pump using special filling adapters. The filling adapters have an internal thread G 1/4".

### ☐42 Filling adapters

Type	Ordering number	Ordering designation
CONCEPT2	095179909-0000-10	ARCALUB-C2.LC250-RF-ADAPTER
CONCEPT4	095180818-0000-10	ARCALUB-C4.LC400-RF-ADAPTER
CONCEPT8	095180826-0000-10	ARCALUB-C8.LC800-RF-ADAPTER

### Restriction for unfilled grease cartridges

- greases of consistency class  $\leq$  NLGI 2
- greases with no solid particles (except PTFE)



If the requirements for the lubricating greases are not observed, the manufacturer's guarantees covering the unfilled cartridges and the lubricators will be invalidated.

Each cartridge can be filled a maximum of 3 times. If further filling operations are carried out, the possibility of damage to the cartridge, in the form of wear for example, cannot be ruled out.

Further information can be found in the following publications:

BA 71 | Manual on filling the cartridges |  
<https://www.schaeffler.de/std/1FC7>

## 6 Voltage supply

The CONCEPT2, CONCEPT4 and CONCEPT8 lubricators require an external voltage supply. Various connector types and cable lengths are available for this purpose.

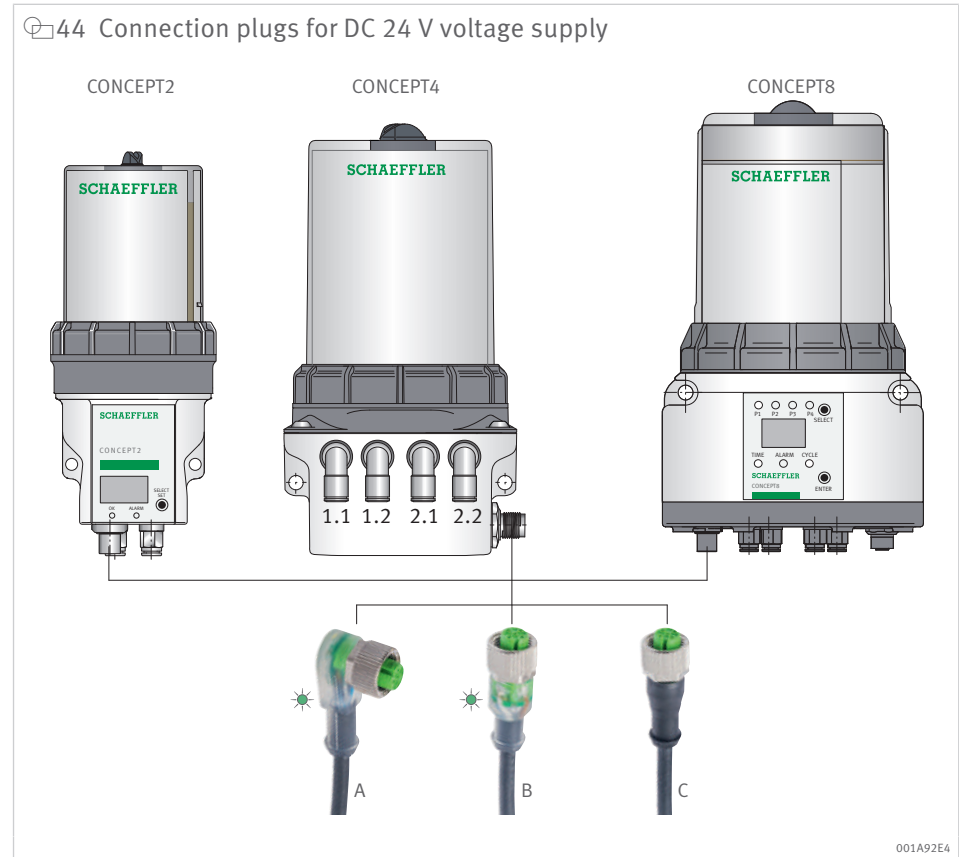

43 Connection plugs M12×1

Type	LED	Length	Ordering number	Ordering designation
		m		
A	•	5	075592240-0000-10	ARCALUB-X.CABLE-M12-5M-LED
		10	077879805-0000-10	ARCALUB-X.CABLE-M12-10M-LED
B	•	5	083788964-0000-10	ARCALUB-X.CABLE-M12X1-5M-LED-S
		10	083788980-0000-10	ARCALUB-X.CABLE-M12X1-10M-LED-S
C	–	10	075378361-0000-10	ARCALUB-X.CABLE-M12-10M

 44 Technical data

Feature		Value
Operating voltage		DC 24 V +6/-6 V
Operating current per contact		max. 4 A
Connection socket		<ul style="list-style-type: none"> <li>• Thread M12×1, self-retaining (recommended tightening torque 0,6 Nm)</li> <li>• 4 pin (A coding)</li> </ul>
Integrated LED	Green	Applied supply voltage DC 24 V
	White	Incoming signal Initiation of lubricant dispensing by external controller
	Yellow	Outgoing signal Feedback of completed lubricant dispensing to external controller
Pin connections	Socket 1	Voltage supply (DC 24 V)
	Socket 2	Activation of the pump by PLC (DC 24 V)
	Socket 3	Ground (GND)
	Socket 4	Output signal (DC 24 V) Return signalling to PLC
	Socket 5	Not assigned
Protection class		IP67 (in inserted and screw-mounted state)
Temperature range	Fixed	-30 °C up to +80 °C
	Moving	-5 °C up to +80 °C
Number of ends, end cross-section		4×0,34 mm <sup>2</sup> (AWG 22)
Length of free ends at connection end		20 mm
Drag chain values		2 million
Outside diameter		5,2 mm
Bending radius	Fixed	10×outside diameter
	Moving	15×outside diameter
Approvals		UL/CSA
Materials	Outer sheath	PUR/PVC, Shore hardness: 85±5
	Wire end insulation	PVC

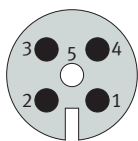

## 7 Demo cases

The demo cases are particularly suitable for the Technical Sales function. Each case contains the essential components of a lubrication system. It can be used to explain the design and function of a lubrication system to the customer and to give an impression of the high quality design of all components.

📦 45 Demo cases



001A7367

1	Demo case for CONCEPT1 and OPTIME C1	2	Demo case for CONCEPT2
3	Demo case for CONCEPT8		

### 📦 45 Demo cases

Demo cases	Scope of delivery <sup>1)</sup>	Ordering number	Ordering designation
CONCEPT1 and OPTIME C1	<a href="https://www.schaeffler.de/std/1FC8">https://www.schaeffler.de/std/1FC8</a>	095287558-0000-10	DEMO-ARCALUB-C1-SET
CONCEPT2	<a href="https://www.schaeffler.de/std/1FC9">https://www.schaeffler.de/std/1FC9</a>	089395433-0000-10	DEMO-ARCALUB-C2-SET
CONCEPT8	<a href="https://www.schaeffler.de/std/1FCA">https://www.schaeffler.de/std/1FCA</a>	084224878-0000-10	DEMO-ARCALUB-C8-SET

<sup>1)</sup> Details about the scope of delivery can be found online in medias.

## 8 Device holders

The device holders facilitate the mounting of the CONCEPT1, OPTIME C1, CONCEPT2 and CONCEPT8 lubricators directly on the equipment to be lubricated or in its vicinity.

### 8.1 Device holders for CONCEPT1 and OPTIME C1

The retaining clamp can either be screwed directly onto a machine or located using the magnetic foot. Use of the mounting support is recommended where strong vibrations occur at the mounting position. The 1-way fixing brackets and 3-way fixing brackets are used together with the mounting support or fixing nipple. The fixing bracket with slots is used together with a bulkhead fitting ►56|47.

46 Dimensions of the device holders

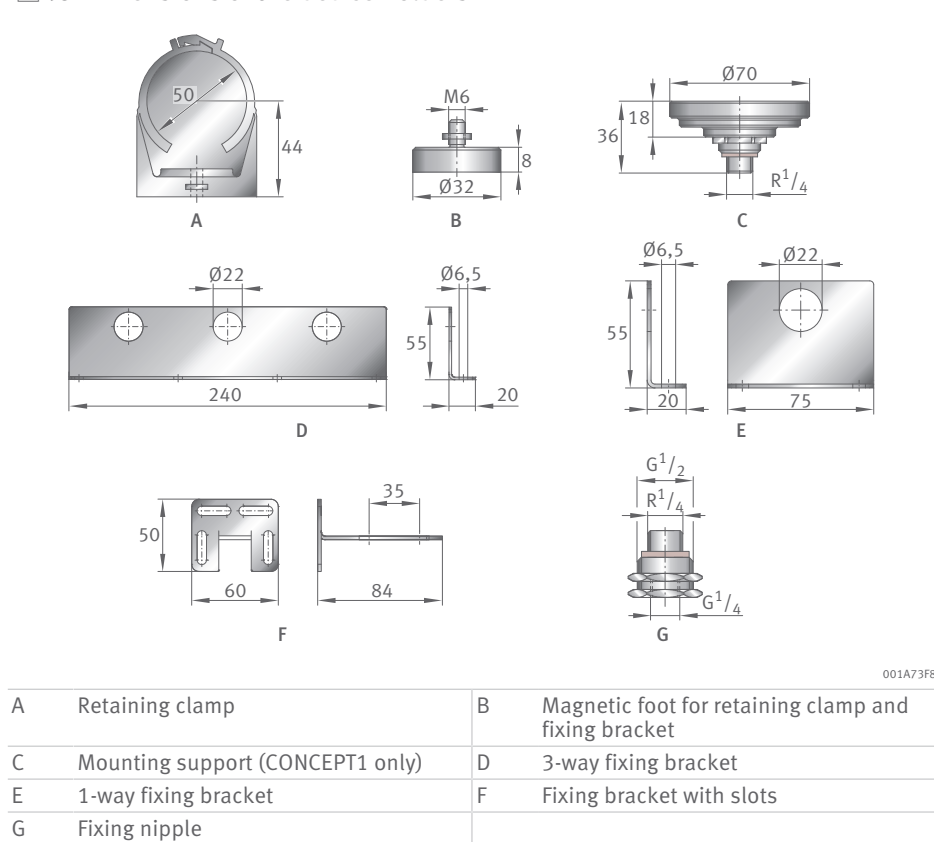

46 Device holders CONCEPT1 and OPTIME C1

Type	Quantity <sup>1)</sup>	Ordering number	Ordering designation
A	3	095285377-0000-10	ARCALUB-C1.CLAMP
B	1	095285385-0000-10	ARCALUB-C1.CLAMP-MAGNET
C	1	095285768-0000-10	ARCALUB-C1.MOUNT-SUPPORT-R1/4
D	1	097881317-0000-10	ARCALUB-C1.FIXING-ANGLE-TRI
E	5	095285741-0000-10	ARCALUB-C1.FIXING-ANGLE
F	3	097880906-0000-10	ARCALUB-C1.FIXING-ANGLE-LONG
G	3	096691620-0000-10	ARCALUB-C1.FIXINGSREW-G1/2-R1/4

<sup>1)</sup> Quantity per packaging unit

### 8.1.1 Bulkhead fitting

The bulkhead fitting is used to fasten the CONCEPT1 or OPTIME C1 in the fixing bracket ARCALUB-C1.FIXING-ANGLE-LONG ▶ 55 | 46.

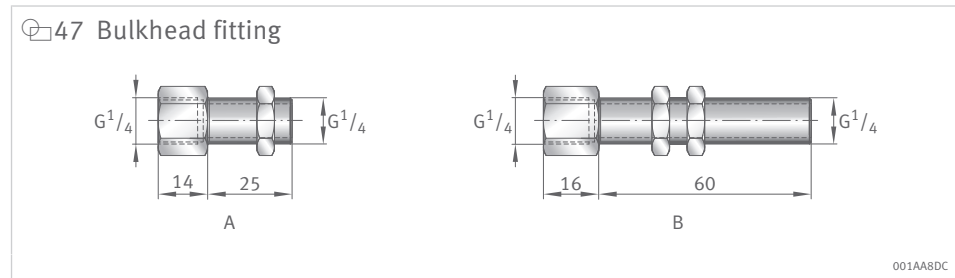

47 Bulkhead fitting

Type	Quantity <sup>1)</sup>	Ordering number	Ordering designation
A	3	097880884-0000-10	ARCALUB-C1.CONNECT-25-G1/4-IA
B	3	097880892-0000-10	ARCALUB-C1.CONNECT-60-G1/4-IA

<sup>1)</sup> Quantity per packaging unit

## 8.2 Device holders for CONCEPT2 and CONCEPT8

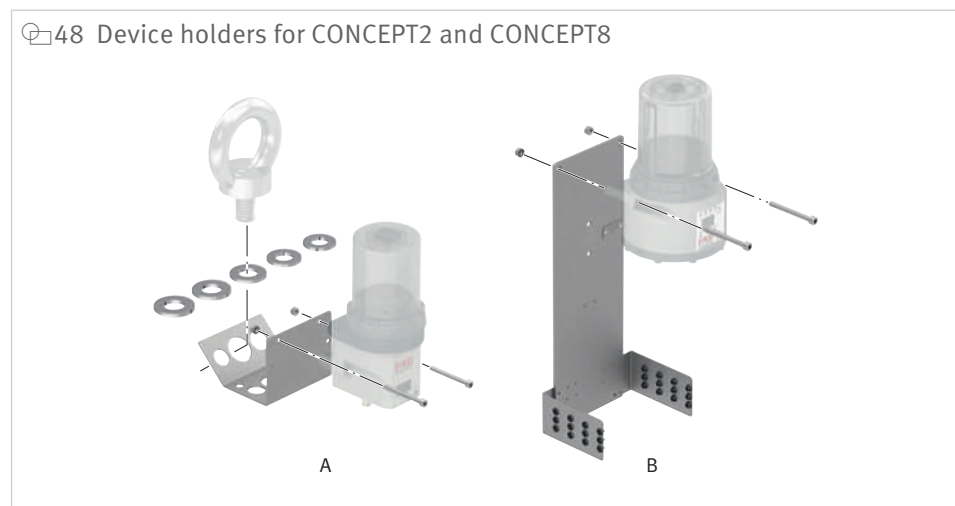

48 Device holders for CONCEPT2 and CONCEPT8

Type	Lubricator	Ordering number	Ordering designation
A	CONCEPT2	092435726-0000-10	ARCALUB-C2.HOLDER-KIT
B	CONCEPT8	093204094-0000-10	ARCALUB-C8.HOLDER-KIT

#### Scope of delivery, device holder for CONCEPT2

- fixing bracket made from high-grade steel
- support washers in different dimensions (5×)
- socket head screws M6×50 with retaining nut (2×)

#### Scope of delivery, device holder for CONCEPT8

- mounting baseplate made from high-grade steel
- bracket made from high-grade steel for the fixing of lubricant lines (2×)
- socket head screws M8×80 with retaining nut (2×)



49 Application examples of device holders

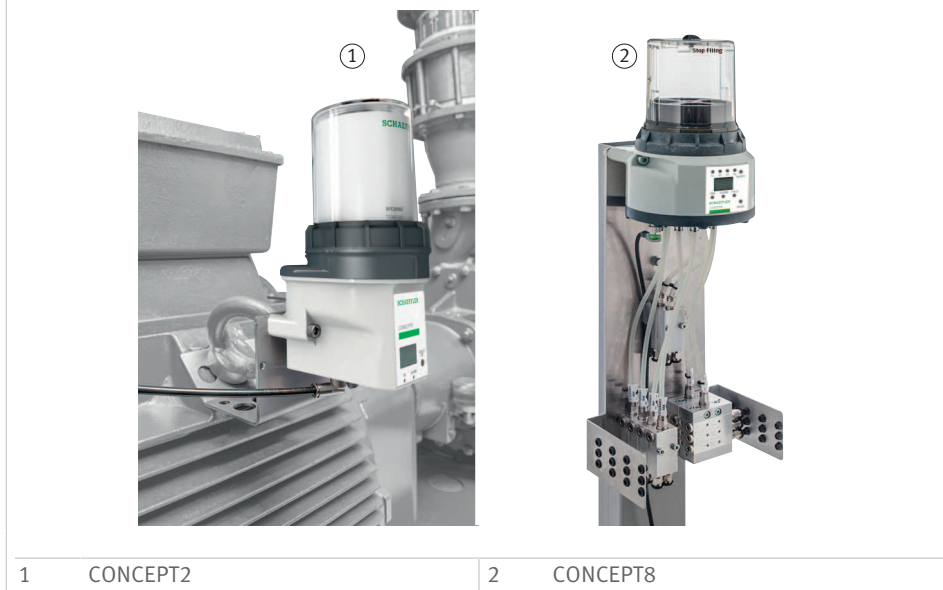

1 CONCEPT2

2 CONCEPT8

## 9 Cover kits

A cover kit protects the lubricator from contamination and ensures the continuous delivery of lubricant.

50 Scope of delivery, cover kit

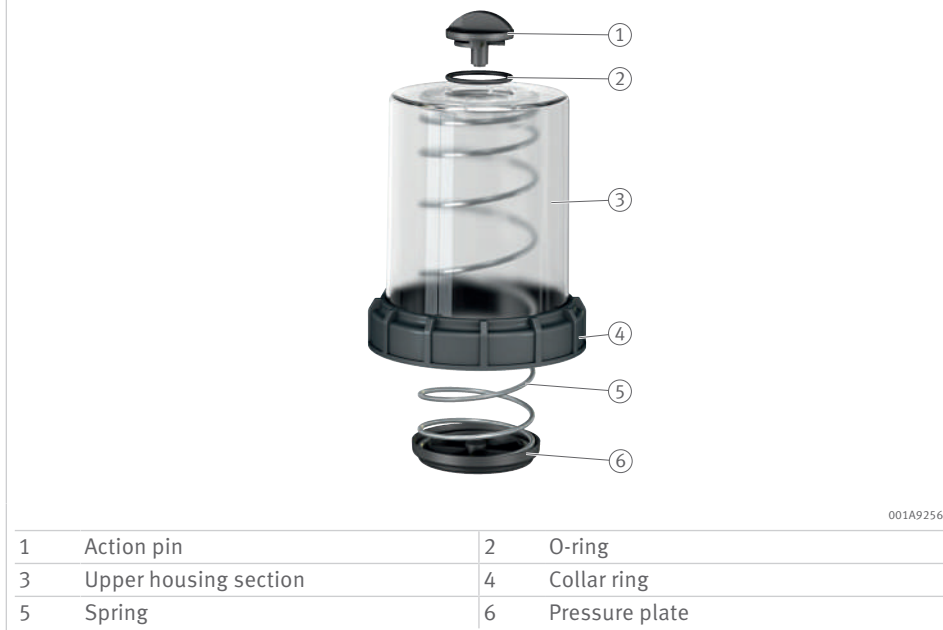

001A9256

1	Action pin	2	O-ring
3	Upper housing section	4	Collar ring
5	Spring	6	Pressure plate

49 Cover kits

Type	Ordering number	Ordering designation
CONCEPT2	092860915-0000-10	ARCALUB-C2.COVER-KIT
CONCEPT4	095111930-0000-10	ARCALUB-C4.COVER-KIT
CONCEPT8	095111948-0000-10	ARCALUB-C8.COVER-KIT

## 10 Lubricant feed lines, fittings

### 10.1 Hoses



Examples of applications in which hoses can be used to connect the lubricator and lubrication points:

- The lubrication point is exposed to strong vibrations.
- The lubrication point is behind a barrier.
- The lubricator cannot be mounted directly at the lubrication point due to excessive temperatures.

Before initial operation of the lubricator, the hose must be completely filled with the same lubricant that is contained in the lubricator.

- ! The maximum permissible lubricant line length must be calculated in accordance with the system design for the respective lubricator ▶6|1.
- ! The maximum permissible bending radius  $R_{\min}$  of the hoses must be observed.
- ! Prefilling of the hoses by means of a lever grease gun is recommended. The use of standard grease containers gives savings in time and cost compared to filling with the CONCEPT2 and CONCEPT8 lubricators.

 52 Hose dimensions

000AF957

 50 Hoses, suitable for drag chain use, unfilled

D <sub>1</sub>	D <sub>2</sub>	Length	Material	R <sub>min</sub>	Burst pressure <sup>1)</sup>	Operating temperature		Ordering number	Ordering designation
						from	up to		
mm	mm	m		mm	bar	°C			
4	2,5	5	PA12	40	90	-20	+80	093041241-0000-10	ARCALUB-X.HOSE-4X2,5-PA12-5M
		10	Black					093041195-0000-10	ARCALUB-X.HOSE-4X2,5-PA12-10M
		50						095775854-0000-10	ARCALUB-X.HOSE-4X2,5-PA12-50M
6	3	5	PA12-PHL	20	100	-20	+80	075526336-0000-10	ARCALUB-X.HOSE-PA12-CLEAR-5M
		10	Transparent					083788441-0000-10	ARCALUB-X.HOSE-PA12-CLEAR-10M
		25						075527251-0000-10	ARCALUB-X.HOSE-PA12-CLEAR-25M
		1000						092515851-0000-10	ARCALUB-X.HOSE-PA12-CLEAR-1000M
6	4	5	PA12	35	90	-20	+80	076691217-0000-10	ARCALUB-X.HOSE-PA12-5M
		10	Black					076691497-0000-10	ARCALUB-X.HOSE-PA12-10M
		50						085842109-0000-10	ARCALUB-X.HOSE-PA12-50M
8	5	5	PA6.6	45	90	-20	+80	083788573-0000-10	ARCALUB-X.HOSE-PA66-5M
		10	Black					083788581-0000-10	ARCALUB-X.HOSE-PA66-10M
		50						083788603-0000-10	ARCALUB-X.HOSE-PA66-50M
8	6	5	PA12	50	75	-40	+90	095285750-0000-10	ARCALUB-C1.HOSE-8X6-PA12-5M
			Transparent						

<sup>1)</sup> The use of hoses which have a lower pressure resistance than the maximum pressure generation in the lubricant pump used is not permissible ►59|51.

 When using the CONCEPT1 or OPTIME C1, a hose outside diameter of 8 mm and a hose inside diameter of 6 mm must be observed.

In order that a hose can be connected to a CONCEPT1 or OPTIME C1 lubricator, a hose connector part with internal thread G 1/4" is screwed to the lubricator ►62|10.2.2.

 51 Reduction in burst pressure under the influence of temperature

Temperature	Burst pressure utilisation
°C	%
23	100
30	83
40	72
50	65
60	57
70	52
80	47

### Hose connectors

Hose connectors connect hoses with different diameters.

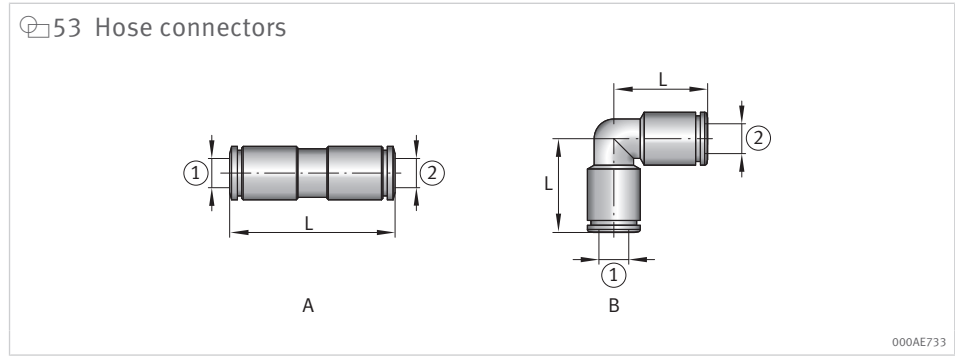

52 Hose connectors

d		Type	l <sub>E</sub>		L	Ordering number	Ordering designation
(1)	(2)		(1)	(2)			
mm	mm		mm	mm	mm		
4	4	A	15	15	32	095770887-0000-10	ARCALUB-X.CONNECT-4-4
4	4	B	15	15	18	095770895-0000-10	ARCALUB-X.CONNECT-4-4-W
6	4	A	16	15	33	093040717-0000-10	ARCALUB-X.CONNECT-6-4
6	6	A	16	16	34	083867112-0000-10	ARCALUB-X.CONNECT-6-6
6	6	B	16	16	19,5	088902250-0000-10	ARCALUB-X.CONNECT-6-6-W
8	6	A	18	16	39,5	083867279-0000-10	ARCALUB-X.CONNECT-8-6
8	8	A	18	18	38	083867309-0000-10	ARCALUB-X.CONNECT-8-8

d mm Hose outside diameter  
 l<sub>E</sub> mm Hose insertion depth

### Y pieces

Y pieces reduce the flow of lubricant from 2 hoses to a collective hose. Use as a sub-distributor is not permitted.

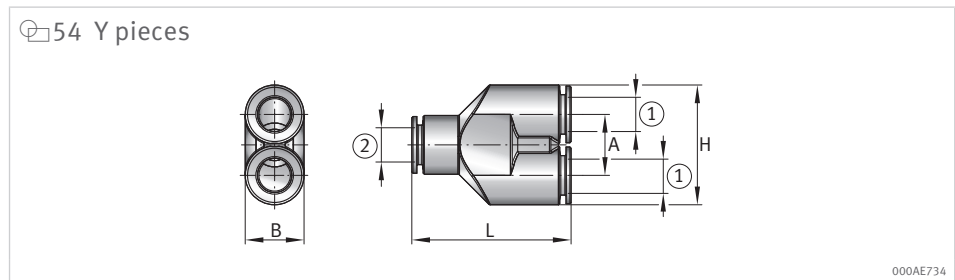

53 Y pieces

d		l <sub>E</sub>	L	A	H	B	Ordering number	Ordering designation
(1)	(2)							
mm	mm	mm	mm	mm	mm	mm		
6	6	16	35	12,5	24,5	12	076693180-0000-10	ARCALUB-X.TUBEFIT-Y-D6
8	8	18	44	14,5	28,5	14	083654640-0000-10	ARCALUB-X.TUBEFIT-Y-D8

d mm Hose outside diameter  
 l<sub>E</sub> mm Hose insertion depth

## 10.2 Fittings

### 10.2.1 Connection adapters

55 Using the connection adapters

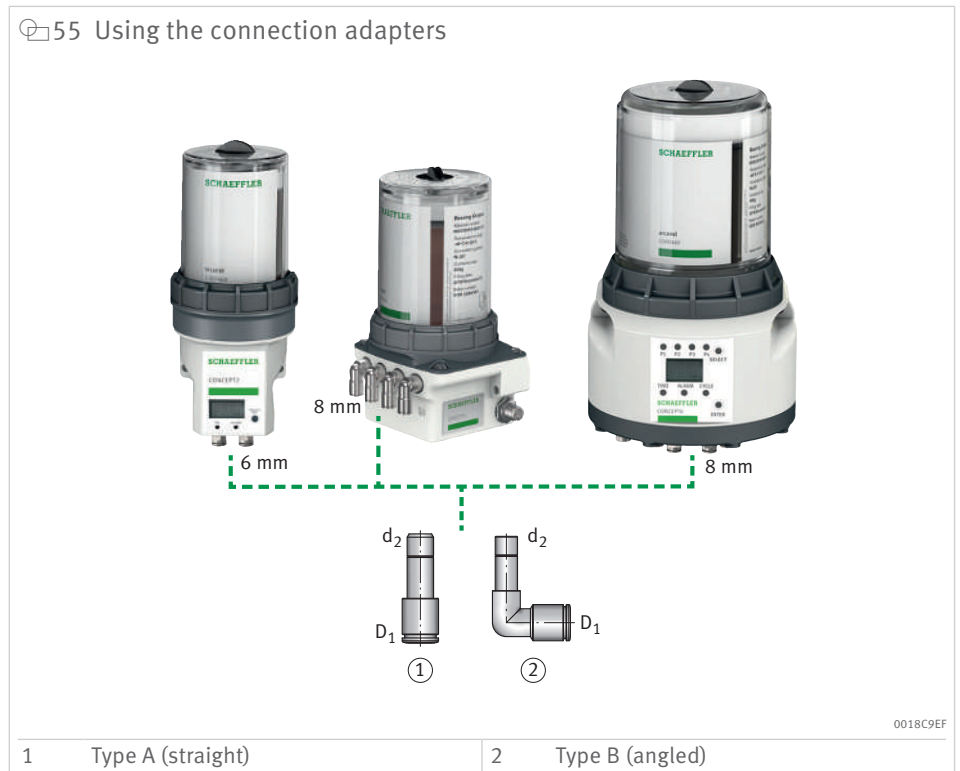

The outside diameter  $d_2$  of the connection adapter is inserted into the outlet of the lubricator up to the end stop. The lubricant line is then inserted into the inside diameter  $D_1$  of the connection adapter.

56 Connection adapter dimensions

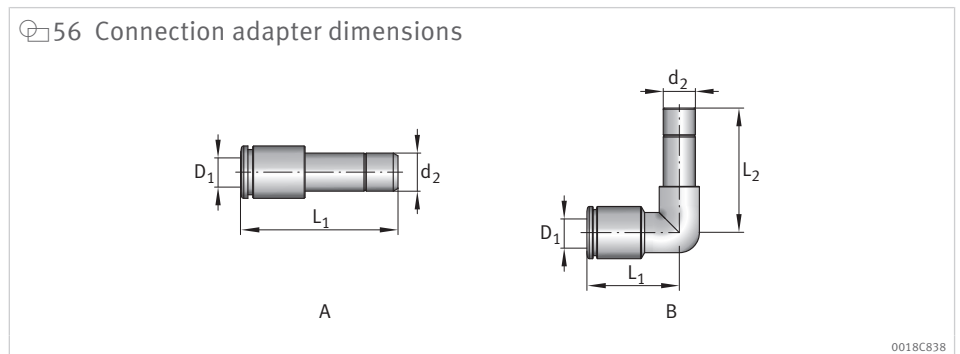

54 Connection adapters

$D_1$ mm	$d_2$ mm	Type	$l_E$ mm	$L_1$ mm	$L_2$ mm	Ordering number	Ordering designation
4	6	A	15	31	–	095777962-0000-10	ARCALUB-X.TUBEFIT-SAT-6A-4I
4	8	A	15	32	–	095777970-0000-10	ARCALUB-X.TUBEFIT-SAT-8A-4I
6	6	B	16	20	27	095058150-0000-10	ARCALUB-X.TUBEFIT-SAT-6A-6I-W
6	8	A	16	34	–	094487979-0000-10	ARCALUB-X.TUBEFIT-SAT8A6I

$l_E$

mm

Hose insertion depth

10.2.2 Hose connector parts

Hose, push fit

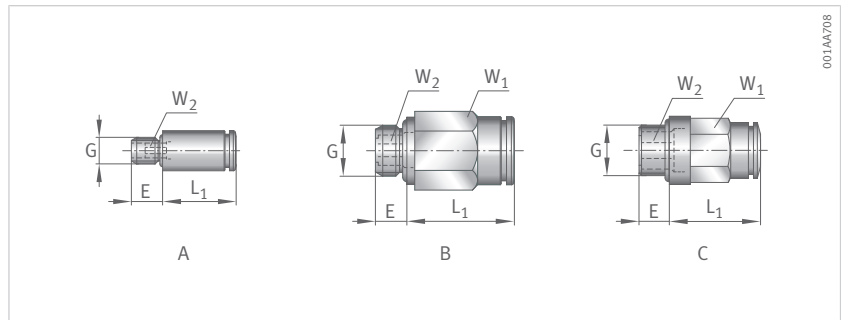

Hose outside diameter	G	Type	Ordering number	Ordering designation	Quantity per packaging unit
mm	–	–	–	–	–
4	M3×0,5	A	093041390-0000-10	ARCALUB-X.TUBEFIT-M3-SAT034G-S	1
4	M6×1	A	095777636-0000-10	ARCALUB-X.TUBEFIT-M6-SAT064G	1
4	M10×1	B	095777911-0000-10	ARCALUB-X.TUBEFIT-M10X1-SAT104G	1
4	M6×1	E	095777644-0000-10	ARCALUB-X.TUBEFIT-M6-SAT064W	1
4	M10×1	E	095777954-0000-10	ARCALUB-X.TUBEFIT-M10X1-SAT104W	1
6	M5×0,8	A	077937490-0000-10	ARCALUB-X.TUBEFIT-M5-SAT056G	1
6	M6×1	A	075527472-0000-10	ARCALUB-X.TUBEFIT-M6-SAT066G	1
6	M8×1	B	079567428-0000-10	ARCALUB-X.TUBEFIT-M8X1-SAT086G	1
6	M10×1	B	075527626-0000-10	ARCALUB-X.TUBEFIT-M10X1-SAT106G	1
6	G 1/8"	C	084465905-0000-10	ARCALUB-X.TUBEFIT-G1/8-SAT186G	1
6	G 1/4"	C	079567606-0000-10	ARCALUB-X.TUBEFIT-G1/4-SAT146G	1
6	M5×0,8	E	079567401-0000-10	ARCALUB-X.TUBEFIT-M5-SAT056W	1
6	M6×1	E	075676621-0000-10	ARCALUB-X.TUBEFIT-M6-SAT066W	1
6	M8×1	E	079567584-0000-10	ARCALUB-X.TUBEFIT-M8X1-SAT086W	1
6	M10×1	E	076968553-0000-10	ARCALUB-X.TUBEFIT-M10X1-SAT106W	1
6	G 1/8"	E	084465964-0000-10	ARCALUB-X.TUBEFIT-G1/8-SAT186W	1
6	G 1/4"	F	079567622-0000-10	ARCALUB-X.TUBEFIT-G1/4-SAT146W	1
8	M8×1	B	083654216-0000-10	ARCALUB-X.TUBEFIT-M8X1-SAT088G	1
8	M10×1	B	083654356-0000-10	ARCALUB-X.TUBEFIT-M10X1-SAT108G	1
8	G 1/8"	B	083654534-0000-10	ARCALUB-X.TUBEFIT-G1/8-SAT188G	1
8	G 1/4"	C	083654607-0000-10	ARCALUB-X.TUBEFIT-G1/4-SAT148G	1
8	G 1/4" (internal)	D	095287051-0000-10	ARCALUB-C1.TUBEFIT-G1/4I-SAT148G	10
8	M8×1	E	083654275-0000-10	ARCALUB-X.TUBEFIT-M8X1-SAT088W	1
8	M10×1	E	083654402-0000-10	ARCALUB-X.TUBEFIT-M10X1-SAT108W	1
8	G 1/8"	E	083654577-0000-10	ARCALUB-X.TUBEFIT-G1/8-SAT188W	1
8	G 1/4"	F	083654623-0000-10	ARCALUB-X.TUBEFIT-G1/4-SAT148W	1

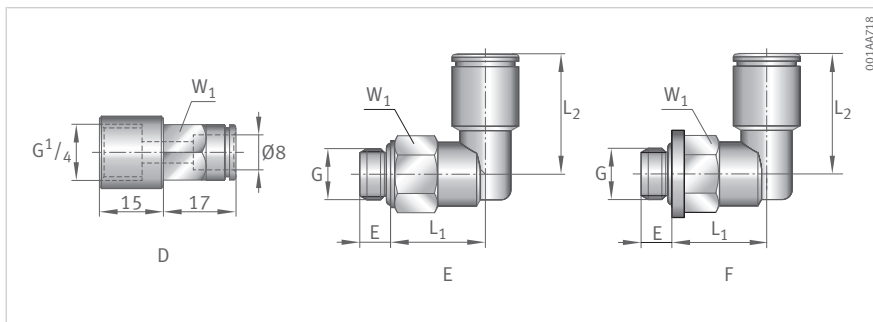

Hose insertion depth	W <sub>1</sub>	W <sub>2</sub>	L <sub>1</sub>	L <sub>2</sub>	E	Seal
mm	mm	mm	mm	mm	mm	–
15	–	1,5	16,5	–	5	Flat sealing over O-ring
15	–	2,5	16,5	–	7	Flat sealing over O-ring
14	–	2,5	14,5	–	8	Metallic sealing over thread
12	9	–	11	18	5	Flat sealing over O-ring
12	13	–	18,5	20	6	Flat sealing over O-ring
16	–	2,5	18,5	–	4	Flat sealing over O-ring
16	–	2,5	18,5	–	4	Flat sealing over O-ring
16	11	4	25,5	–	4	Metallic sealing over thread
16	11	4	25,5	–	8	Metallic sealing over thread
16	11	4	18	–	5,5	Flat sealing over O-ring
16	11	4	15,5	–	7	Flat sealing over O-ring
15	9	–	11	20,5	4	Flat sealing over O-ring
16	9	–	10,5	21,5	5	Flat sealing over O-ring
16	9	–	11	21	7	Metallic sealing over thread
16	13	–	14	22	6	Flat sealing over O-ring
16	13	–	14	21	5,5	Flat sealing over O-ring
16	13	–	16	21	6,5	Flat sealing over O-ring
18	11	4	20,5	–	7	Flat sealing over O-ring
18	13	5	20,5	–	6	Flat sealing over O-ring
18	13	5	20,5	–	6	Flat sealing over O-ring
18	13	6	16,5	–	7	Flat sealing over O-ring
10	13	–	–	–	–	Flat sealing over sealing washer
18	13	–	14,5	23,5	6	Flat sealing over O-ring
18	13	–	18,5	23,5	6	Flat sealing over O-ring
18	13	–	14,5	23,5	5,5	Flat sealing over O-ring
18	13	–	16,5	23,5	8	Flat sealing over O-ring

### 10.2.3 Extensions

Extensions are screwed into place between the lubricator and the lubrication point if a direct connection is not possible due to the adjacent construction.

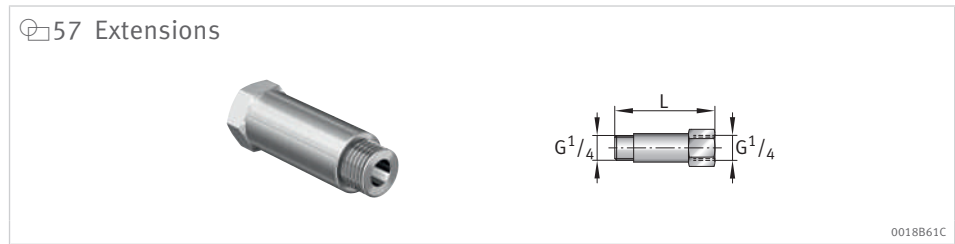

55 Extensions

L mm	Quantity <sup>1)</sup>	Ordering number	Ordering designation
35	10	095285725-0000-10	ARCALUB-C1.EXTEND-35MM-G1/4
50	10	095285733-0000-10	ARCALUB-C1.EXTEND-50MM-G1/4

<sup>1)</sup> Quantity per packaging unit

### 10.2.4 Connecting pieces

Connecting pieces are screwed into place between the lubricator and the lubrication point if a direct connection is not possible due to the adjacent construction.

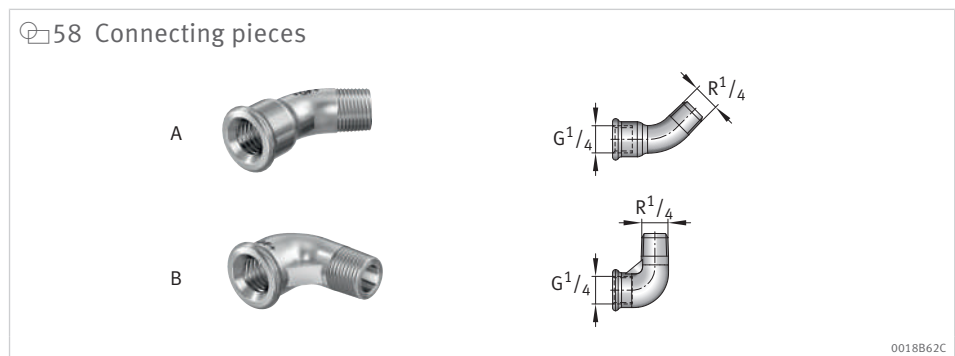

56 Connecting pieces

Type	Angle °	Quantity <sup>1)</sup>	Ordering number	Ordering designation
A	45	10	095285393-0000-10	ARCALUB-C1.CONNECT-45-G1/4-IA
B	90	10	095285407-0000-10	ARCALUB-C1.CONNECT-90-G1/4-IA

<sup>1)</sup> Quantity per packaging unit

### 10.2.5 Reducing nipples

Reducing nipples are required in order to be able to use the lubricators at lubrication points with different threaded connectors.

At one end, the reducing nipples have an internal thread  $G \frac{1}{4}$ " , into which the lubricator is screwed. At the other end of the reducing nipples is an external thread, that is selected according to the threaded connector of the application and screw mounted with this accordingly.

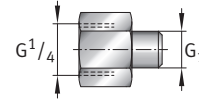

 59 Reducing nipples

0018B60C

 57 Reducing nipples

<b>G<sub>1</sub></b>	<b>Quantity <sup>1)</sup></b>	<b>Ordering number</b>	<b>Ordering designation</b>
G 1/8"	10	095285792-0000-10	ARCALUB-C1.NIPPLE-G1/8-G1/4
G 1/4"	10	095285784-0000-10	ARCALUB-C1.NIPPLE-G1/4-G1/4
G 3/8"	10	095285806-0000-10	ARCALUB-C1.NIPPLE-G3/8-G1/4
M6	10	095286071-0000-10	ARCALUB-C1.NIPPLE-M6-G1/4
M8	10	095286080-0000-10	ARCALUB-C1.NIPPLE-M8-G1/4
M8×1	10	095301585-0000-10	ARCALUB-C1.NIPPLE-M8X1-G1/4
M10	10	095286101-0000-10	ARCALUB-C1.NIPPLE-M10-G1/4
M10×1	10	095286721-0000-10	ARCALUB-C1.NIPPLE-M10X1-G1/4
M12	10	095286730-0000-10	ARCALUB-C1.NIPPLE-M12-G1/4
M12×1,5	10	095286748-0000-10	ARCALUB-C1.NIPPLE-M12X1,5-G1/4
UNF 1/4	10	095286756-0000-10	ARCALUB-C1.NIPPLE-UNF1/4-G1/4

1) Quantity per packaging unit

## 10.2.6 Check valves

Check valves are used with oil lubrication to prevent the filled lubricant lines from leaking.

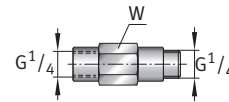
 60 Check valve CONCEPT1

0018B63C

 58 Check valve CONCEPT1

<b>W</b>	<b>Ordering number</b>	<b>Ordering designation</b>
<b>mm</b>		
17	095287515-0000-10	ARCALUB-C1.CONNECT-OIL-VALVE-G1/4

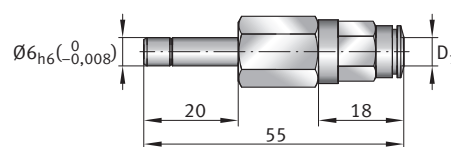
 61 Check valve CONCEPT2, CONCEPT4 and CONCEPT8

001AC4C1

 59 Check valve CONCEPT2, CONCEPT4, CONCEPT8

<b>D<sub>1</sub></b>	<b>Hose insertion depth</b>	<b>W</b>	<b>Ordering number</b>	<b>Ordering designation</b>
<b>mm</b>	<b>mm</b>	<b>mm</b>		
6	16	13	092927122-0000-10	ARCALUB-X.OIL-VALVE-SAT106G

## 10.3 Sub-distributors

### 10.3.1 Splitters

Splitters distribute a delivery volume to 2 outlets in uniform volumes.

For this purpose, splitters are fitted with chokes that create a pressure differential of approx. 10 bar between the inlet and outlet for the lubricant. Each outlet is provided with a check valve in order to prevent overflow of the lubricant from one outlet to the other.

The choke gap size is dependent on the lubricant. The size of the gap is identifiable from the engraving at the splitter inlet:

- Grease: 20 corresponds to a choke gap size of 0,20 mm
- Oil: 0,5 corresponds to a choke gap size of 0,005 mm

62 Splitter with hydraulic schematic

1	Inlet	2	Outlet
3	Chokes	4	Choke gap engraving
5	Check valves		

001ABE2D

### 60 Splitters

Type	Ordering number	Ordering designation
Grease	081307497-0000-10	ARCALUB-X.SPLITTER-2X-STRAIGHT-GREASE
Oil	074969218-0000-10	ARCALUB-X.SPLITTER-2X-STRAIGHT-OIL

### Characteristics

- The connected lubrication points are supplied with lubricant as follows:
  - identical lubricant
  - identical lubricant quantity
  - identical lubrication interval
- Requirement for lubrication lines at the inlet:
  - maximum lubricant line length to pump: 300 mm
- Requirement for lubricant lines at the outlet:
  - approximately equal lubricant line lengths ( $\pm 10\%$  difference)
  - identical line cross-sections

- Operating temperature +10 °C to +60 °C
- Lubricant:
  - oils
  - greases up to NLGI 2 (no solid content)

**!** Cascading, in other words the combination of splitters or progressive distributors, is not permissible.

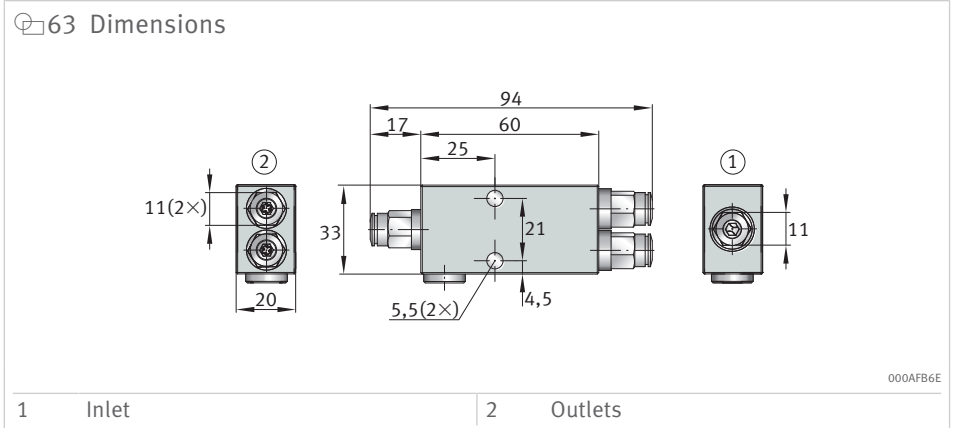

#### 61 Technical data

Feature		Value
Operating pressure	required	> 10 bar
	max.	100 bar
Metering accuracy with correct operation		±10 %
Material	Housing	Aluminium
	Hose connector parts	Brass, nickel-plated
Hose diameter		6 mm
Hose insertion depth		16 mm

#### Scope of delivery

The splitter is supplied with 3 connection fittings with a thread M10×1 for the hose connection diameter 6 mm.

For the connection of hoses with an outside diameter of 8 mm, the corresponding connection fittings must be ordered separately ▶ 62|10.2.2.

### 10.3.2 Progressive distributors

In progressive distributors, the lubricant is distributed by the follower piston control of the individual distributor discs consecutively to the lubrication points. Each of the 3 outlets is additionally provided with a check valve in order to prevent overflow of the lubricant from one outlet to another.



☐62 Progressive distributors

Type	Ordering number	Ordering designation
TS3-25	093204060-0000-10	ARCALUB-X.PROGDIV-3X-RIGHT-0.05CCM

#### Characteristics

- The connected lubrication points are supplied with lubricant as follows:
  - identical lubricant
  - identical lubricant quantity
  - identical lubrication interval
- Requirement for lubrication lines at the inlet:
  - maximum lubricant line length to pump: 300 mm
- Requirement for lubricant lines at the outlet:
  - identical line cross-sections
- Operating temperature +10 °C to +60 °C
- Lubricant:
  - oils
  - greases up to NLGI 2 (no solid content)

⚠ Cascading, in other words the combination of splitters or progressive distributors, is not permissible.

## 65 Dimensions

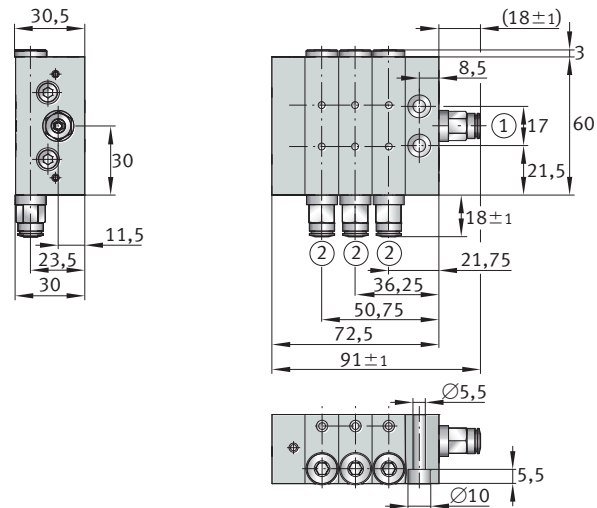

000AFB6D

1 Inlet

2 Outlet

## 63 Technical data

Feature		Value
Operating pressure	required	> 10 bar
	max.	100 bar
Metering accuracy with correct operation		±10 %
Material	Housing	Aluminium
	Hose connector parts	Brass, nickel-plated
Metering volume		0,025 cm <sup>3</sup>
Hose insertion depth		16 mm

## Scope of delivery

The progressive distributor is supplied with 4 connection fittings with a thread M10×1 for the hose connection diameter 6 mm.

For the connection of hoses with an outside diameter of 8 mm, the corresponding connection fittings must be ordered separately ►62|10.2.2.

## Mounting regulations

For correct function of progressive distributors, the following rules must be observed in mounting:

- The progressive distributor may only be mounted on a flat surface. Otherwise, stresses can lead to jamming of the control pistons.
- In all applications with oil lubrication, the progressive distributor must be mounted such that the control pistons are in a horizontal position. Otherwise, gap losses and the influence of gravity can lead to descent of the control pistons.

66 Alignment of the progressive distributor in mounting

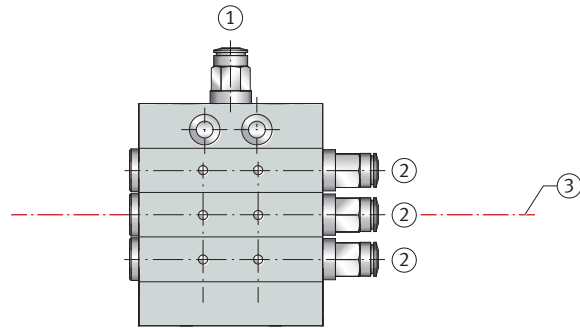

000B0473

1	Inlet	2	Outlet
3	Horizontal position of control pistons		

## 10.4 Tools

### 10.4.1 Hose cutter

The use of a special hose cutter ensures secure and pressure-tight connection of the lubrication line.

67 Hose cutter



0018F139

64 Hose cutter

Type	Ordering number	Ordering designation
Hose cutter	083788620-0000-10	ARCALUB-X.HOSE-CUTTOOL

68 Secure connection by means of hose cutter

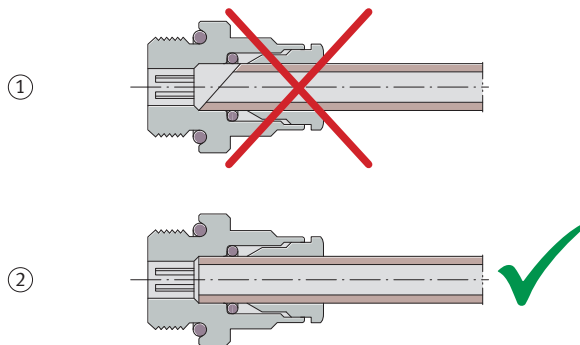

0018F190

1	Without hose cutter	2	With hose cutter
---	---------------------	---	------------------

## 11 Lubricant application

### 11.1 Brushes

Brushes are used for the continuous lubrication of gear teeth, drive chains and conveyor chains. They are available in various sizes and thus cover a wide range of different applications.

The type B brushes are suitable for use in the food industry. A felt insert is located between the 2 rows of bristles, which ensures that the lubricating oil is evenly distributed over the entire width of the brush.

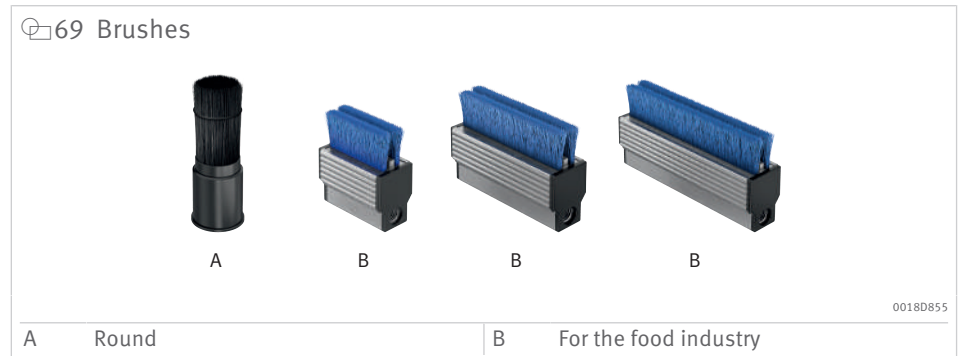

#### 65 Brushes

Type	Brush length or brush diameter	Ordering number	Ordering designation
	mm		
A	25	095285334-0000-10	ARCALUB-C1.BRUSH-25MM-G1/4-G
B	40	095285342-0000-10	ARCALUB-C1.BRUSH-40MM-G1/4-G
	70	095285350-0000-10	ARCALUB-C1.BRUSH-70MM-G1/4-G
	100	095285369-0000-10	ARCALUB-C1.BRUSH-100MM-G1/4-G

## 11.2 Lubrication gears

Lubrication gears are used for the automatic and continuous relubrication of tooth sets.

The lubrication gear is brought into contact with the tooth set to be lubricated, normally a drive pinion or toothed rack. The lubrication gear transfers the lubricant to the tooth set in contact. There is no transmission of force or torque.

The use of open cell PU foam as a material for lubrication gears ensures optimum supply of lubricant to the tooth set for very long periods. The material used stores the lubricant and dispenses it again in very small metering quantities. This prevents both overlubrication and lubricant starvation.

### Characteristics

- lubrication gear made from open cell PU foam
- operating temperature:  $-30\text{ °C}$  up to  $+140\text{ °C}$
- maximum permissible circumferential speed at the outside diameter of the lubrication gear:  $5\text{ m/s}$
- segmented construction
- little installation work required
- lubricant:
  - oils up to  $30000\text{ mm}^2/\text{s}$  ( $+40\text{ °C}$ )
  - greases up to NLGI 3 (no solid content)

In all versions, integrated grooves ensure that the lubricant is transported from the hollow axle to the gear tooth surface.

 In selection, it must be decided on the basis of design perspectives whether the lubrication gear is to be arranged on the tooth set of a toothed rack or of a drive pinion.

It should preferably be mounted on a drive pinion, since lubricant distribution is better in this case than with mounting on a toothed rack.

The lubrication gears must be prefilled with suitable lubricant before initial operation.

 At very high circumferential speeds of  $> 2\text{ m/s}$ , Schaeffler recommends that the customer fits a cover to give protection against grease thrown off by centrifugal force.



70 Designs of lubrication gears

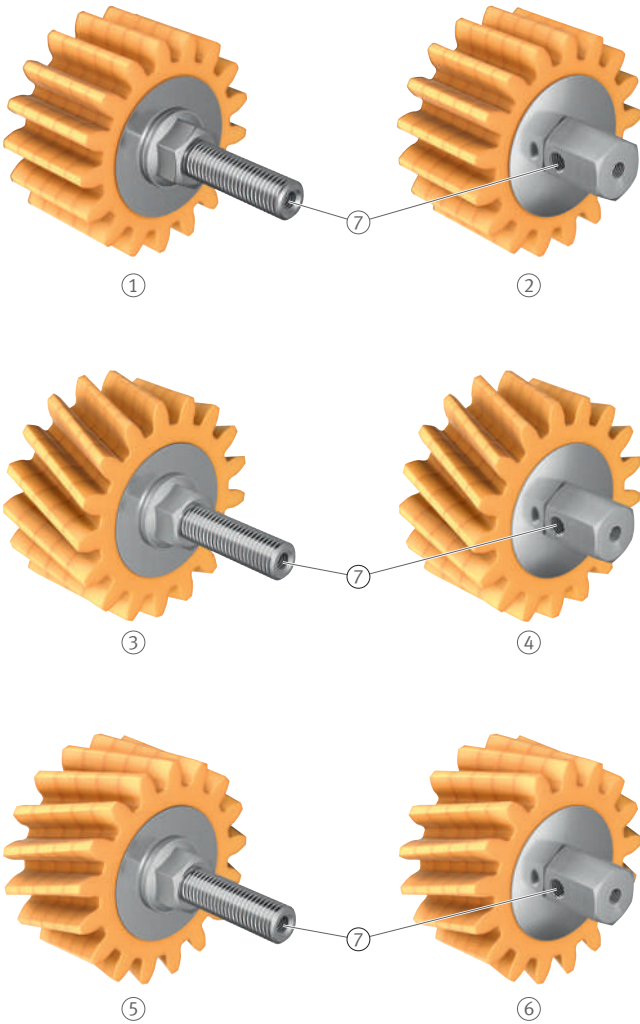

001A9365

1	Straight teeth, axial lubricant feed	2	Straight teeth, radial lubricant feed
3	Right hand helical teeth, axial lubricant feed	4	Right hand helical teeth, radial lubricant feed
5	Left hand helical teeth, axial lubricant feed	6	Left hand helical teeth, radial lubricant feed
7	Connector for lubricant feed		

## 11.2.1 Straight teeth

Type A: Lubricant feed, axial

Type B: Lubricant feed, radial

Type	Modulus	Teeth	d	B	Ordering number	Ordering designation
–	mm	Quantity	mm	mm	–	–
A	1,5	24	36	39	093283016-0000-10	ARCALUB-X.PINION-MD1,5-Z24-B15-G-G
A	2	17	34	38	093283032-0000-10	ARCALUB-X.PINION-MD2,0-Z17-B20-G-G
A	3	17	51	57	093283059-0000-10	ARCALUB-X.PINION-MD3,0-Z17-B30-G-G
A	4	17	68	76	093283075-0000-10	ARCALUB-X.PINION-MD4,0-Z17-B40-G-G
A	5	17	85	95	093283091-0000-10	ARCALUB-X.PINION-MD5,0-Z17-B50-G-G
A	6	17	102	114	093283113-0000-10	ARCALUB-X.PINION-MD6,0-Z17-B60-G-G
A	8	17	136	152	093283130-0000-10	ARCALUB-X.PINION-MD8,0-Z17-B80-G-G
A	10	17	170	190	093283156-0000-10	ARCALUB-X.PINION-MD10,0-Z17-B100-G-G
B	1,5	24	36	39	093283024-0000-10	ARCALUB-X.PINION-MD1,5-Z24-B15-G-W
B	2	17	34	38	093283040-0000-10	ARCALUB-X.PINION-MD2,0-Z17-B20-G-W
B	3	17	51	57	093283067-0000-10	ARCALUB-X.PINION-MD3,0-Z17-B30-G-W
B	4	17	68	76	093283083-0000-10	ARCALUB-X.PINION-MD4,0-Z17-B40-G-W
B	5	17	85	95	093283105-0000-10	ARCALUB-X.PINION-MD5,0-Z17-B50-G-W
B	6	17	102	114	093283121-0000-10	ARCALUB-X.PINION-MD6,0-Z17-B60-G-W
B	8	17	136	152	093283148-0000-10	ARCALUB-X.PINION-MD8,0-Z17-B80-G-W
B	10	17	170	190	093283164-0000-10	ARCALUB-X.PINION-MD10,0-Z17-B100-G-W

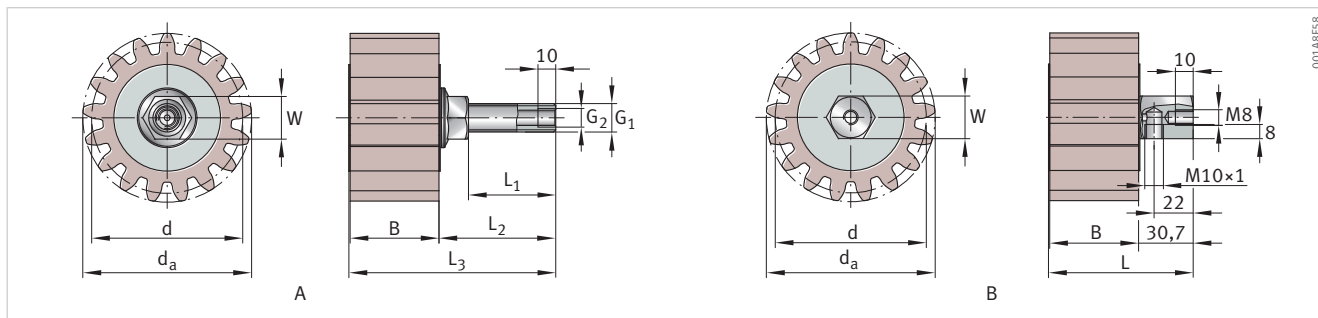

<b>d<sub>a</sub></b>	<b>L</b>	<b>L<sub>1</sub></b>	<b>L<sub>2</sub></b>	<b>L<sub>3</sub></b>	<b>G<sub>1</sub></b>	<b>G<sub>2</sub></b>	<b>W</b>	<b>Helix angle</b>
mm	mm	mm	mm	mm	mm	–	–	°
15	–	34	44,7	60,4	M10	M6	15	0
20	–	32	42,5	63,2	M10	M6	15	0
30	–	30	40,5	71,2	M10	M6	15	0
40	–	30	40,5	81,2	M10	M6	15	0
50	–	49	65,7	116,4	M16	M10×1	24	0
60	–	49	75,7	126,4	M16	M10×1	24	0
80	–	49	95,7	146,4	M16	M10×1	24	0
100	–	49	115,7	166,4	M16	M10×1	24	0
15	46,4	–	–	–	–	–	–	0
20	51,4	–	–	–	–	–	–	0
30	61,4	–	–	–	–	–	–	0
40	71,4	–	–	–	–	–	–	0
50	81,4	–	–	–	–	–	–	0
60	91,4	–	–	–	–	–	–	0
80	111	–	–	–	–	–	–	0
100	131	–	–	–	–	–	–	0

## 11.2.2 Left hand helical teeth

Type A: Lubricant feed, axial

Type B: Lubricant feed, radial

Type	Modulus	Teeth	d	B	Ordering number	Ordering designation
–	mm	Quantity	mm	mm	–	–
A	1,5	24	38,2	15	093283334-0000-10	ARCALUB-X.PINION-MD1,5-Z24-B15-SL-G
A	2	17	36,08	20	093283350-0000-10	ARCALUB-X.PINION-MD2,0-Z17-B20-SL-G
A	3	17	54,11	30	093283377-0000-10	ARCALUB-X.PINION-MD3,0-Z17-B30-SL-G
A	4	17	72,15	40	093283393-0000-10	ARCALUB-X.PINION-MD4,0-Z17-B40-SL-G
A	5	17	90,19	50	093283415-0000-10	ARCALUB-X.PINION-MD5,0-Z17-B50-SL-G
A	6	17	108,23	60	093283431-0000-10	ARCALUB-X.PINION-MD6,0-Z17-B60-SL-G
A	8	17	144,3	80	093283458-0000-10	ARCALUB-X.PINION-MD8,0-Z17-B80-SL-G
A	10	17	180,38	100	093283474-0000-10	ARCALUB-X.PINION-MD10,0-Z17-B100-SL-G
B	1,5	24	38,2	15	093283342-0000-10	ARCALUB-X.PINION-MD1,5-Z24-B15-SL-W
B	2	17	36,08	20	093283369-0000-10	ARCALUB-X.PINION-MD2,0-Z17-B20-SL-W
B	3	17	54,11	30	093283385-0000-10	ARCALUB-X.PINION-MD3,0-Z17-B30-SL-W
B	4	17	72,15	40	093283407-0000-10	ARCALUB-X.PINION-MD4,0-Z17-B40-SL-W
B	5	17	90,19	50	093283423-0000-10	ARCALUB-X.PINION-MD5,0-Z17-B50-SL-W
B	6	17	108,23	60	093283440-0000-10	ARCALUB-X.PINION-MD6,0-Z17-B60-SL-W
B	8	17	144,3	80	093283466-0000-10	ARCALUB-X.PINION-MD8,0-Z17-B80-SL-W
B	10	17	180,38	100	093283482-0000-10	ARCALUB-X.PINION-MD10,0-Z17-B100-SL-W

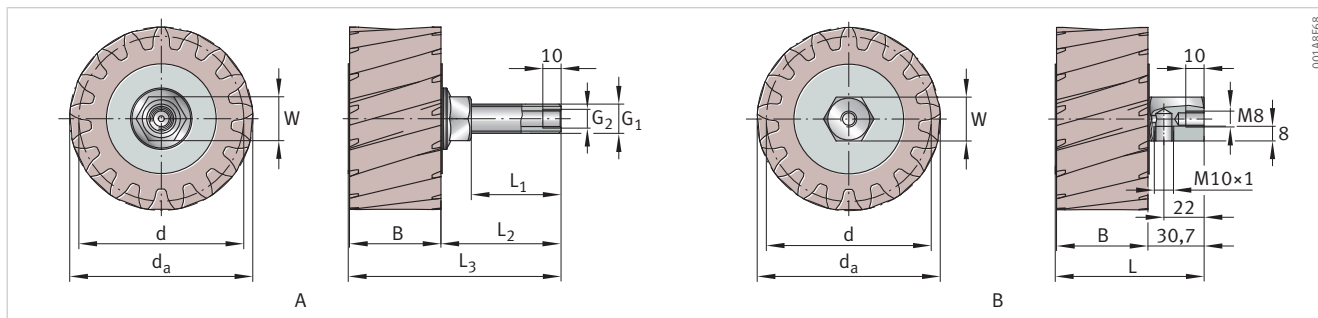

<b>d<sub>a</sub></b>	<b>L</b>	<b>L<sub>1</sub></b>	<b>L<sub>2</sub></b>	<b>L<sub>3</sub></b>	<b>G<sub>1</sub></b>	<b>G<sub>2</sub></b>	<b>W</b>	<b>Helix angle</b>
mm	mm	mm	mm	mm	mm	–	–	°
41,2	–	34	44,7	60,4	M10	M6	15	19,53
40,1	–	32	42,5	63,2	M10	M6	15	19,53
60,1	–	30	40,5	71,2	M10	M6	15	19,53
80,2	–	30	40,5	81,2	M10	M6	15	19,53
100,2	–	49	65,7	116,4	M16	M10×1	24	19,53
120,2	–	49	75,7	126,4	M16	M10×1	24	19,53
160,3	–	49	95,7	146,4	M16	M10×1	24	19,53
200,4	–	49	115,7	166,4	M16	M10×1	24	19,53
41,2	46,4	–	–	–	–	–	–	19,53
40,1	51,4	–	–	–	–	–	–	19,53
60,1	61,4	–	–	–	–	–	–	19,53
80,2	71,4	–	–	–	–	–	–	19,53
100,2	81,4	–	–	–	–	–	–	19,53
120,2	91,4	–	–	–	–	–	–	19,53
160,3	111	–	–	–	–	–	–	19,53
200,4	131	–	–	–	–	–	–	19,53

### 11.2.3 Right hand helical teeth

Type A: Lubricant feed, axial

Type B: Lubricant feed, radial

Type	Modulus	Teeth	d	B	Ordering number	Ordering designation
–	mm	Quantity	mm	mm	–	–
A	1,5	24	38,2	15	093283172-0000-10	ARCALUB-X.PINION-MD1,5-Z24-B15-SR-G
A	2	17	36,08	20	093283199-0000-10	ARCALUB-X.PINION-MD2,0-Z17-B20-SR-G
A	3	17	54,11	30	093283210-0000-10	ARCALUB-X.PINION-MD3,0-Z17-B30-SR-G
A	4	17	72,15	40	093283237-0000-10	ARCALUB-X.PINION-MD4,0-Z17-B40-SR-G
A	5	17	90,19	50	093283253-0000-10	ARCALUB-X.PINION-MD5,0-Z17-B50-SR-G
A	6	17	108,23	60	093283270-0000-10	ARCALUB-X.PINION-MD6,0-Z17-B60-SR-G
A	8	17	144,3	80	093283296-0000-10	ARCALUB-X.PINION-MD8,0-Z17-B80-SR-G
A	10	17	180,38	100	093283318-0000-10	ARCALUB-X.PINION-MD10,0-Z17-B100-SR-G
B	1,5	24	38,2	15	093283180-0000-10	ARCALUB-X.PINION-MD1,5-Z24-B15-SR-W
B	2	17	36,08	20	093283202-0000-10	ARCALUB-X.PINION-MD2,0-Z17-B20-SR-W
B	3	17	54,11	30	093283229-0000-10	ARCALUB-X.PINION-MD3,0-Z17-B30-SR-W
B	4	17	72,15	40	093283245-0000-10	ARCALUB-X.PINION-MD4,0-Z17-B40-SR-W
B	5	17	90,19	50	093283261-0000-10	ARCALUB-X.PINION-MD5,0-Z17-B50-SR-W
B	6	17	108,23	60	093283288-0000-10	ARCALUB-X.PINION-MD6,0-Z17-B60-SR-W
B	8	17	144,3	80	093283300-0000-10	ARCALUB-X.PINION-MD8,0-Z17-B80-SR-W
B	10	17	180,38	100	093283326-0000-10	ARCALUB-X.PINION-MD10,0-Z17-B100-SR-W

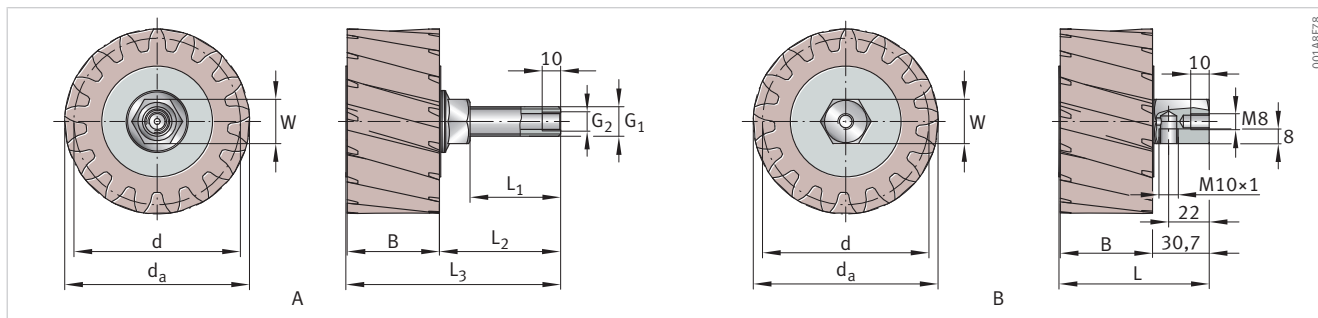

<b>d<sub>a</sub></b>	<b>L</b>	<b>L<sub>1</sub></b>	<b>L<sub>2</sub></b>	<b>L<sub>3</sub></b>	<b>G<sub>1</sub></b>	<b>G<sub>2</sub></b>	<b>W</b>	<b>Helix angle</b>
mm	mm	mm	mm	mm	mm	–	–	°
41,2	–	34	44,7	60,4	M10	M6	15	19,53
40,1	–	32	42,5	63,2	M10	M6	15	19,53
60,1	–	30	40,5	71,2	M10	M6	15	19,53
80,2	–	30	40,5	81,2	M10	M6	15	19,53
100,2	–	49	65,7	116,4	M16	M10×1	24	19,53
120,2	–	49	75,7	126,4	M16	M10×1	24	19,53
160,3	–	49	95,7	146,4	M16	M10×1	24	19,53
200,4	–	49	115,7	166,4	M16	M10×1	24	19,53
41,2	46,4	–	–	–	–	–	–	19,53
40,1	51,4	–	–	–	–	–	–	19,53
60,1	61,4	–	–	–	–	–	–	19,53
80,2	71,4	–	–	–	–	–	–	19,53
100,2	81,4	–	–	–	–	–	–	19,53
120,2	91,4	–	–	–	–	–	–	19,53
160,3	111	–	–	–	–	–	–	19,53
200,4	131	–	–	–	–	–	–	19,53

### 11.3 Chain lubrication pinions

Chain lubrication pinions are used to supply chains with chain oil according to requirements and fully automatically.

The rollers are made from open cell PU foam and transfer very small quantities of oil to the highest points on the chain links. From there, the oil reaches the spaces between the links and thus to the decisive lubrication points between the pins and sleeves. There is no coating of other surfaces of the chain with oil, which is unnecessary and, in some cases, can even be damaging.

The chain pinions, made from a special plastic, transmit the force necessary to drive the rollers. Despite the non-uniform surface of the chain links, very quiet running of the chain lubrication pinion can be achieved even at very high speeds.

The contact force of the PU rollers responsible for lubricant transfer to the chain is automatically adjusted to the optimum value since the chain rollers are always at the base of the pinion. This prevents wear of the PU rollers. There is no slippage between the PU rollers and the chain surface.

#### Characteristics

- chain pinion made from plastic
- lubricant application by means of rollers made from open cell PU foam
- operating temperature: 0 °C up to +60 °C
- maximum permissible circumferential speed at the outside diameter of the chain pinion: 7 m/s
- lubricant: oil



At very high chain speeds of  $> 2,5$  m/s, Schaeffler recommends that the customer fits a cover to give protection against oil flown off by centrifugal force.



71 Designs of chain lubrication pinions

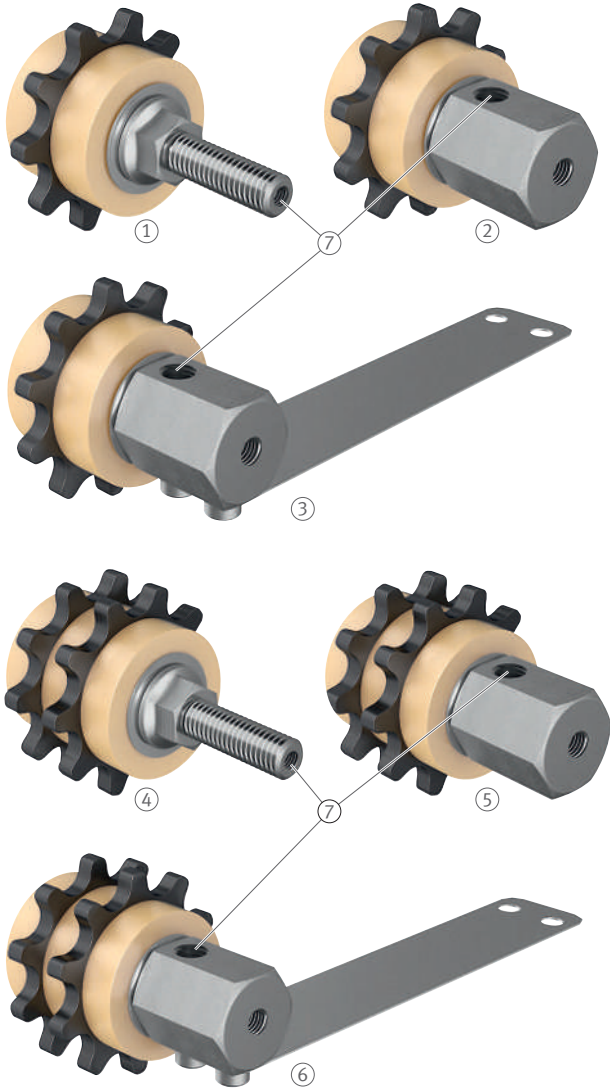

001A9385

1	Simplex, axial lubricant feed	2	Simplex, radial lubricant feed
3	Simplex, radial lubricant feed and spring plate	4	Duplex, axial lubricant feed
5	Duplex, radial lubricant feed	6	Duplex, radial lubricant feed and spring plate
7	Connector for lubricant feed		

## 11.3.1 Chain lubrication pinions in simplex design

Type A: Lubricant feed, axial

Type B: Lubricant feed, radial

Type	Chain type according to ISO 606	Teeth	d	Ordering number	Ordering designation
–	–	<b>Quantity</b>	<b>mm</b>	–	–
A	08 A/B-1	12	49,07	093283490-0000-10	ARCALUB-X.CHAIN-PINION-08AB1-Z12-G
A	10 A/B-1	10	51,37	093283547-0000-10	ARCALUB-X.CHAIN-PINION-10AB1-Z10-G
A	12 B-1	8	49,78	093283601-0000-10	ARCALUB-X.CHAIN-PINION-12B1-Z8-G
A	16 B-1	8	66,37	093283652-0000-10	ARCALUB-X.CHAIN-PINION-16B1-Z8-G
B	08 A/B-1	12	49,07	093283504-0000-10	ARCALUB-X.CHAIN-PINION-08AB1-Z12-W
B	10 A/B-1	10	51,37	093283555-0000-10	ARCALUB-X.CHAIN-PINION-10AB1-Z10-W
B	12 B-1	8	49,78	093283610-0000-10	ARCALUB-X.CHAIN-PINION-12B1-Z8-W
B	16 B-1	8	66,37	093283660-0000-10	ARCALUB-X.CHAIN-PINION-16B1-Z8-W

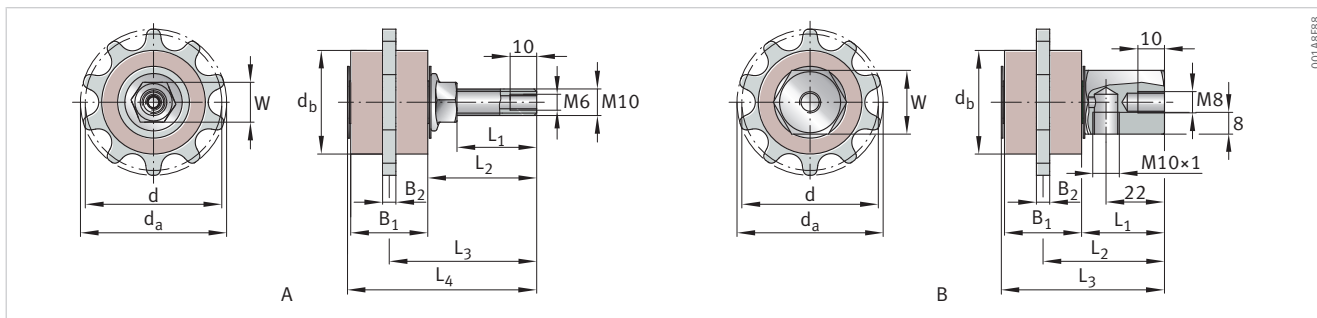

<b>d<sub>a</sub></b>	<b>d<sub>b</sub></b>	<b>B<sub>1</sub></b>	<b>B<sub>2</sub></b>	<b>L<sub>1</sub></b>	<b>L<sub>2</sub></b>	<b>L<sub>3</sub></b>	<b>L<sub>4</sub></b>	<b>W</b>
mm	mm	mm	mm	mm	mm	mm	mm	mm
53	39	29	5	30	41	55,5	71,2	15
55	39	29	5	30	41	55,5	71,2	15
55	36	29	5	30	41	55,5	71,2	15
75	48	40	10	30	40,5	40	81,2	15
53	39	29	5	31,2	45,7	61,4	–	24
55	39	29	5	31,2	45,7	61,4	–	24
55	36	29	5	31,2	45,7	61,4	–	24
75	48	40	10	30,7	50,7	71,4	–	24

## 11.3.2 Chain lubrication pinions in simplex design with spring plate

Type C: Lubricant feed, radial, with spring plate

Type	Chain type according to ISO 606	Teeth	d	Ordering number	Ordering designation
–	–	<b>Quantity</b>	<b>mm</b>	–	–
C	08 A/B-1	12	49,07	093283512-0000-10	ARCALUB-X.CHAIN-PINION-08AB1-Z12-WF
C	10 A/B-1	10	51,37	093283563-0000-10	ARCALUB-X.CHAIN-PINION-10AB1-Z10-WF
C	16 B-1	8	66,37	093283679-0000-10	ARCALUB-X.CHAIN-PINION-16B1-Z8-WF

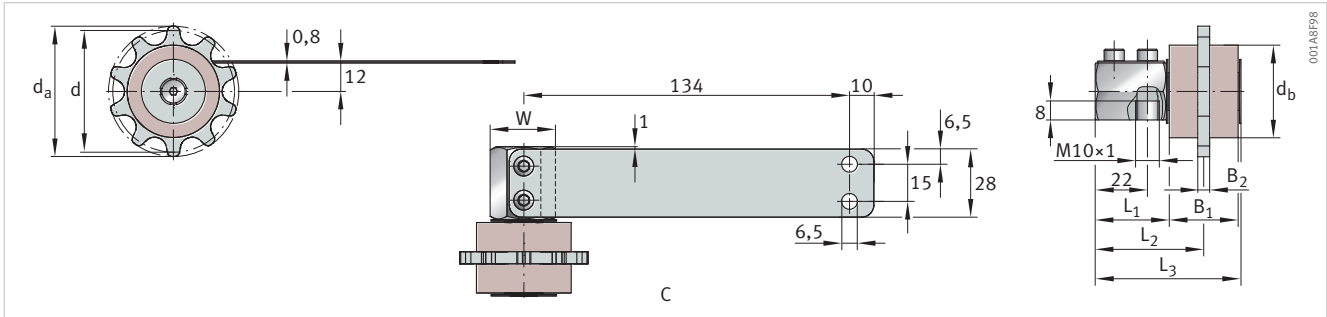

<b>d<sub>a</sub></b>	<b>d<sub>b</sub></b>	<b>B<sub>1</sub></b>	<b>B<sub>2</sub></b>	<b>L<sub>1</sub></b>	<b>L<sub>2</sub></b>	<b>L<sub>3</sub></b>	<b>L<sub>4</sub></b>	<b>W</b>
mm	mm	mm	mm	mm	mm	mm	mm	mm
53	39	29	5	31,2	45,7	61,4	-	24
55	39	29	5	31,2	45,7	61,4	-	24
75	48	40	10	30,7	50,7	71,4	-	24

### 11.3.3 Chain lubrication pinions in duplex design

Type A: Lubricant feed, axial

Type B: Lubricant feed, radial

Type	Chain type according to ISO 606	Teeth	d	Ordering number	Ordering designation
–	–	<b>Quantity</b>	<b>mm</b>	–	–
A	08 A/B-2	12	49,07	093283520-0000-10	ARCALUB-X.CHAIN-PINION-08AB2-Z12-G
A	10 A/B-2	10	51,37	093283571-0000-10	ARCALUB-X.CHAIN-PINION-10AB2-Z10-G
A	12 B-2	8	49,78	093283628-0000-10	ARCALUB-X.CHAIN-PINION-12B2-Z8-G
A	16 B-2	8	66,37	093283687-0000-10	ARCALUB-X.CHAIN-PINION-16B2-Z8-G
B	08 A/B-2	12	49,07	093283539-0000-10	ARCALUB-X.CHAIN-PINION-08AB2-Z12-W
B	10 A/B-2	10	51,37	093283580-0000-10	ARCALUB-X.CHAIN-PINION-10AB2-Z10-W
B	12 B-2	8	49,78	093283636-0000-10	ARCALUB-X.CHAIN-PINION-12B2-Z8-W
B	16 B-2	8	66,37	093283695-0000-10	ARCALUB-X.CHAIN-PINION-16B2-Z8-W

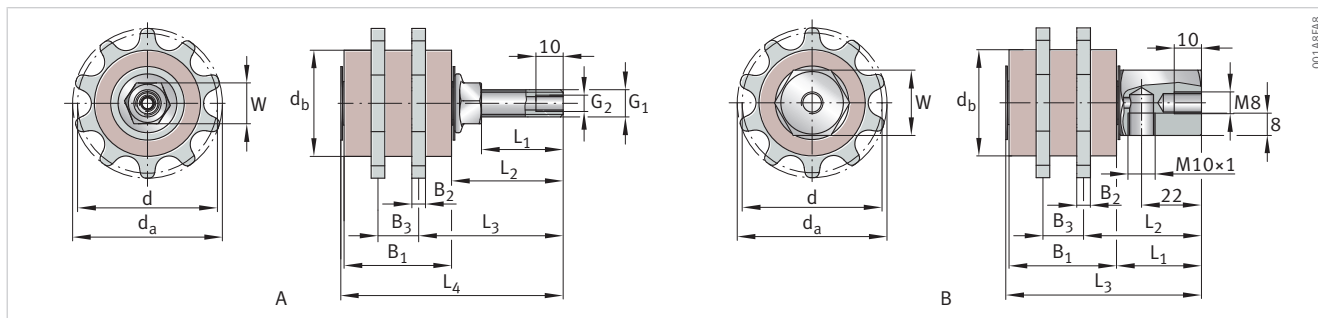

$d_a$	$d_b$	$B_1$	$B_2$	$B_3$	$L_1$	$L_2$	$L_3$	$L_4$	$G_1$	$G_2$	$W$
mm	mm	mm	mm	mm	mm	mm	mm	mm	–	–	mm
53	39	29	5	15	30	41	55,5	71,2	M10	M6	15
55	39	29	5	15	30	41	55,5	71,2	M10	M6	15
55	36	29	5	15	30	41	55,5	71,2	M10	M6	15
75	48	40	10	30	30	40,5	40	81,2	M16	M10×1	15
53	39	29	5	15	31,2	45,7	61,4	–	–	–	24
55	39	29	5	15	31,2	45,7	61,4	–	–	–	24
55	36	29	5	15	31,2	45,7	61,4	–	–	–	24
75	48	40	10	30	30,7	50,7	71,4	–	–	–	24

### 11.3.4 Chain lubrication pinions in duplex design with spring plate

Type C: Lubricant feed, radial, with spring plate

Type D: Lubricant feed, radial, with 2 spring plates

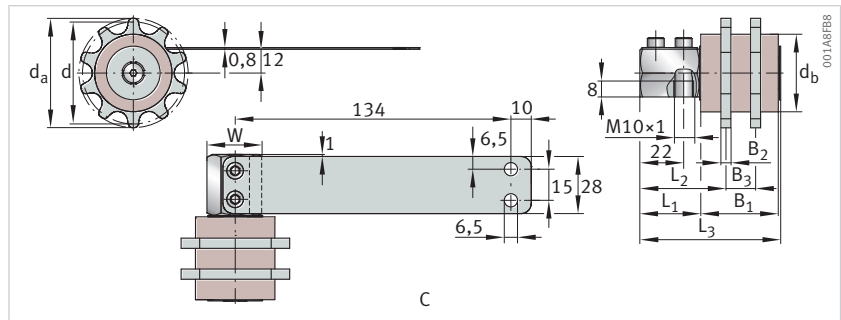

Type	Chain type according to ISO 606	Teeth	d	Ordering number	Ordering designation
-	-	<b>Quantity</b>	<b>mm</b>	-	-
C	10 A/B-2	12	49,07	093283598-0000-10	ARCALUB-X.CHAIN-PINION-10AB2-Z10-WF
C	12 B-2	10	51,37	093283644-0000-10	ARCALUB-X.CHAIN-PINION-12B2-Z8-WF
D	16 B-2	8	66,37	093283709-0000-10	ARCALUB-X.CHAIN-PINION-16B2-Z8-WF



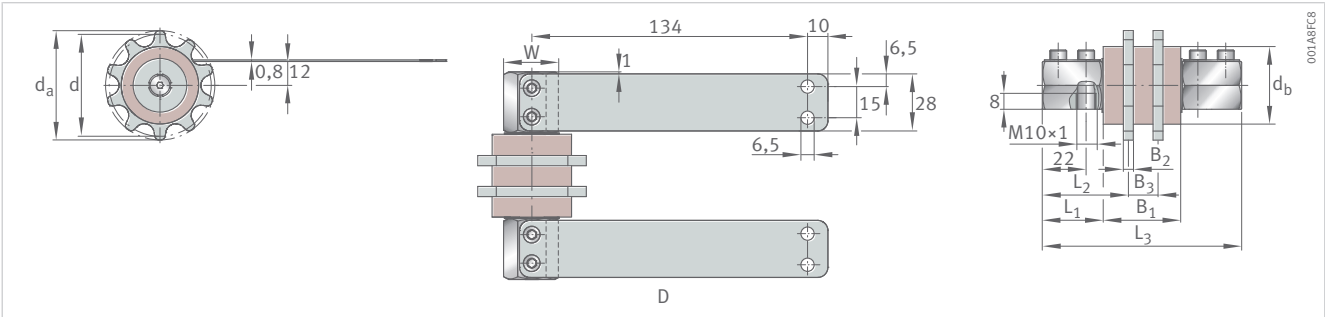

<b>d<sub>a</sub></b>	<b>d<sub>b</sub></b>	<b>B<sub>1</sub></b>	<b>B<sub>2</sub></b>	<b>B<sub>3</sub></b>	<b>L<sub>1</sub></b>	<b>L<sub>2</sub></b>	<b>L<sub>3</sub></b>	<b>L<sub>4</sub></b>	<b>G<sub>1</sub></b>	<b>G<sub>2</sub></b>	<b>W</b>
mm	mm	mm	mm	mm	mm	mm	mm	mm	-	-	mm
53	39	29	5	15	31,2	45,7	61,4	-	-	-	24
55	39	29	5	15	31,2	45,7	61,4	-	-	-	24
75	48	80	10	30	30,7	56,05	142,1	-	-	-	24

### 11.4 Lubrication rollers

In lubrication rollers, lubricant is applied by means of rollers made from open cell PU foam. All designs are fitted with a spring plate.

72 Lubrication of a roller chain by means of a lubrication roller

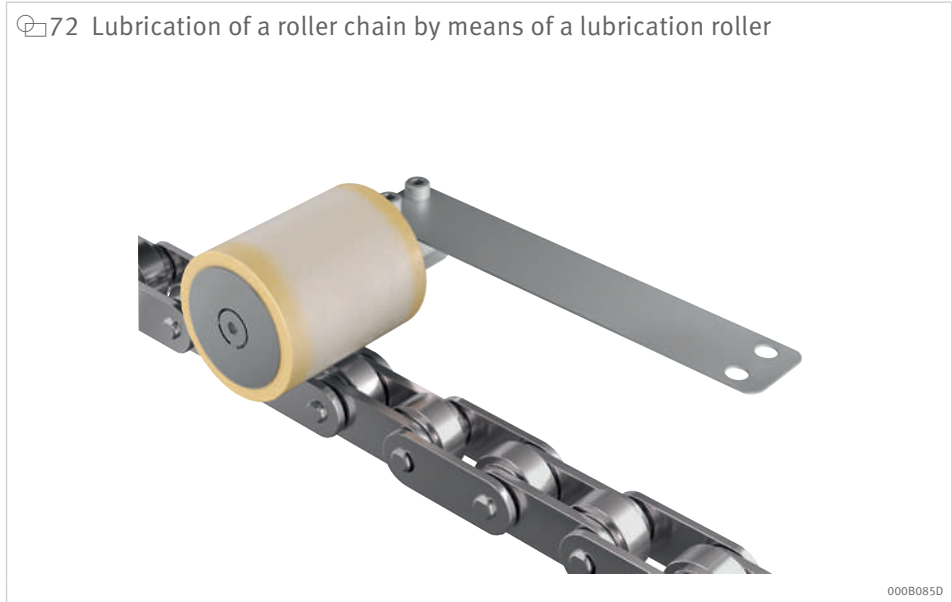

000B085D

Lubrication rollers are used for the lubrication of raceways, for example on roller chains.

73 Lubrication roller dimensions

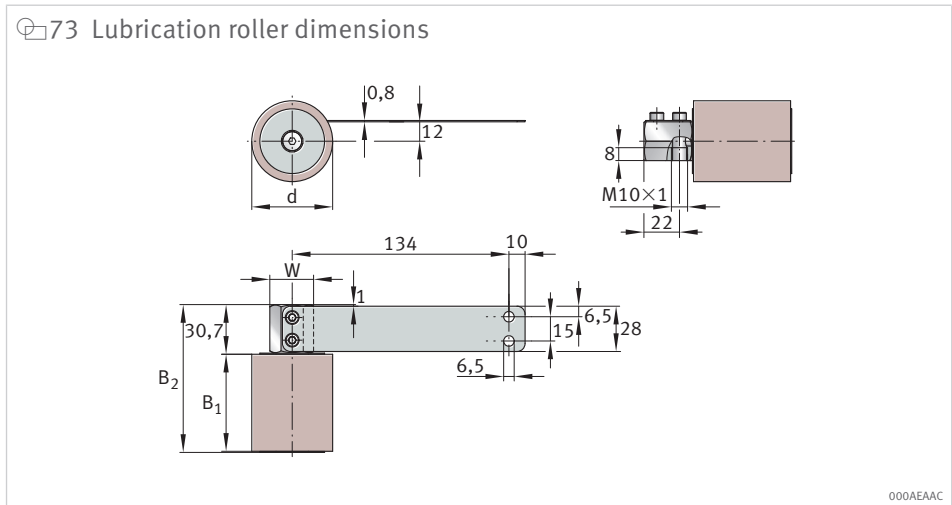

000AEAC

66 Lubrication rollers

d	B <sub>1</sub>	B <sub>2</sub>	W	Ordering number	Ordering designation
mm	mm	mm	mm		
30	45	76,4	24	093283717-0000-10	ARCALUB-X.ROLE-D30-B45-WF
40	30	61,4	24	093283725-0000-10	ARCALUB-X.ROLE-D40-B30-WF
50	40	71,4	24	093283733-0000-10	ARCALUB-X.ROLE-D50-B40-WF
50	60	91,4	24	093283741-0000-10	ARCALUB-X.ROLE-D50-B60-WF
60	45	76,4	24	093283750-0000-10	ARCALUB-X.ROLE-D60-B45-WF

## 12 Manual lubrication tools

### 12.1 Lever grease gun

 74 Lever grease gun



000B432E

 67 Lever grease gun

Type	Ordering number	Ordering designation
Lever grease gun	039064115-0000-10	ARCA-GREASE-GUN

The lever grease gun ARCA-GREASE-GUN can be used to achieve high lubrication pressures without issue.

The proven TWIN-LOCK system protects the piston guide of the lever grease gun against wear-induced abrasion during continuous operation and thus prevents the risk of quasi-lubrication to machines and equipment.

The EVER-FLOW system ensures that the lever grease gun functions correctly even with highly viscous grease and very low temperatures. Due to the vacuum created during the pumping operation, even tough biological grease can be delivered easily.

 68 Technical data

Feature		Value
Fill quantity	Grease cartridge	400 g (up to NLGI 3)
	Loose grease	500 cm <sup>3</sup> (up to NLGI 3)
Operating pressure		400 bar
Delivery rate		Approx. 1,9 cm <sup>3</sup> /stroke
Pressure pipe	Material	Steel, zinc-coated
Diameter		56 mm
Length		296 mm
Threaded connector		G 1/8"

### Hoses

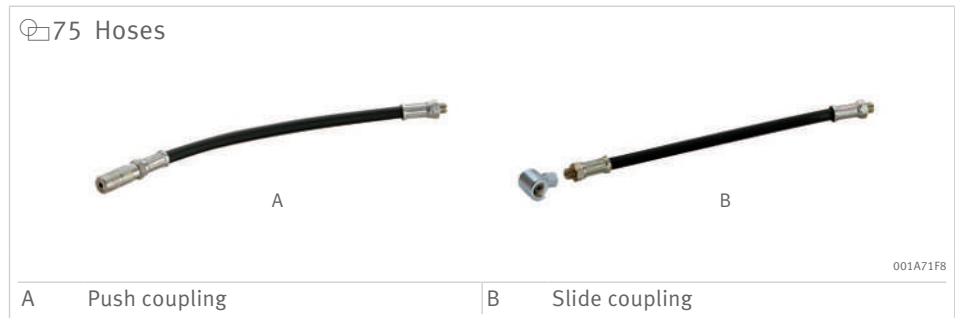

69 Hoses

Type	Ordering number	Ordering designation
A	039064123-0000-10	ARCA-GREASE-GUN.HOSE
B	039697010-0000-10	ARCA-GREASE-GUN.HOOK-ON-HOSE

The lubricant is transported from the lever grease gun to the required lubrication nipple via a hose.

70 Technical data

Characteristic	Type	
	A	B
Coupling	4-jaw nozzle for taper type lubrication nipples to DIN 71412	Slide coupling for button head lubrication nipples to DIN 3404-16
Length	300 mm	300 mm
Threaded connector (both sides)	R 1/8"	R 1/8"

### Ordering example



Schaeffler recommends using hose type ARCA-GREASE-GUN.HOSE with optional clamping nozzle ARCA-PUMP-BARREL.FIT-CLAMP-N or a hose with slide coupling ARCA-GREASE-GUN.HOOK-ON-HOSE when using the ARCA-GREASE-GUN.

71 Ordering example

Item	Quantity	Ordering number	Ordering designation
(1)	1	039064115-0000-10	ARCA-GREASE-GUN
(2)	1	039064123-0000-10	ARCA-GREASE-GUN.HOSE

## 12.1.1 Grease gun

77 Grease gun



001A71AA

72 Grease gun

Type	Ordering number	Ordering designation
Grease gun	301253641-0000-10	ARCA-FILL-GUN-N

The grease gun ARCA-FILL-GUN-N can be used to fill the lubricator. This can be equipped with 400 g Arcanol grease cartridges.

The adapter ARCALUB-C1.NIPPLE-REFILL-GREASE-R1/4 is needed in order to fill the CONCEPT1 lubricator ►18|14.

73 Technical data

Feature	Value	
Dimensions	Outside diameter	56 mm
	Inside diameter	54 mm
	Length	273 mm
Pressure pipe material	Steel, zinc-coated	
Operating pressure	10 bar	
Delivery rate	12 g/Hub	
Threaded connector	R 1/4"	

## 12.1.2 Selection of Arcanol grease cartridges

78 Arcanol grease cartridge



0016F086

74 Grease cartridges filled with 400 g of lubricant

Type	Ordering number	Ordering designation
Arcanol CLEAN-M	069429111-0000-10	ARCANOL-CLEAN-M-400G
Arcanol FOOD2	019143648-0000-10	ARCANOL-FOOD2-400G
Arcanol LOAD150	055358152-0000-10	ARCANOL-LOAD150-400G
Arcanol LOAD220	064741028-0000-10	ARCANOL-LOAD220-400G
Arcanol LOAD400	019143818-0000-11	ARCANOL-LOAD400-400G
Arcanol LOAD460	065825144-0000-10	ARCANOL-LOAD460-400G
Arcanol MULTI2	019143893-0000-11	ARCANOL-MULTI2-400G
Arcanol MULTI3	016727355-0000-11	ARCANOL-MULTI3-400G
Arcanol MULTITOP	019144016-0000-11	ARCANOL-MULTITOP-400G
Arcanol SEMIFLUID	096322918-0000-10	ARCANOL-SEMIFLUID-380G
Arcanol SPEED2,6	062447610-0000-10	ARCANOL-SPEED2,6-400G
Arcanol TEMP90	019144172-0000-10	ARCANOL-TEMP90-400G
Arcanol TEMP110	019144075-0000-10	ARCANOL-TEMP110-400G
Arcanol VIB3	055289568-0000-10	ARCANOL-VIB3-400G

## 12.1.3 Accessories

### 12.1.3.1 Clamping nozzle

#### 79 Clamping nozzle



001A5D31

The hydraulic clamping nozzle ARCA-PUMP-BARREL.FIT-CLAMP-N is used for lubrication via taper type lubrication nipples in accordance with DIN 71412.

#### 75 Clamping nozzle

Type	Quantity <sup>1)</sup>	Ordering number	Ordering designation
Clamping nozzle	2	301253650-0000-10	ARCA-PUMP-BARREL.FIT-CLAMP-N

<sup>1)</sup> Quantity per packaging unit

The ARCA-PUMP-BARREL.FIT-CLAMP-N has a hardened 4 jaw nozzle made of tool steel, which prevents it from slipping off the lubrication nipple. Decoupling from the lubrication nipple is possible up to a pressure of 600 bar courtesy of the high-performance hydraulic seal.

The clamping nozzle can only be used in combination with a hose ►92|70.

#### 76 Technical data

Feature	Value
Threaded connector	R 1/8"
Coupling	4-jaw nozzle for taper type lubrication nipples in accordance with DIN 71412
Linear swivel joint	yes
Check valve	yes
Max. permissible pressure	600 bar

## 12.2 Drum pumps

80 Examples of drum pump kits with grease container

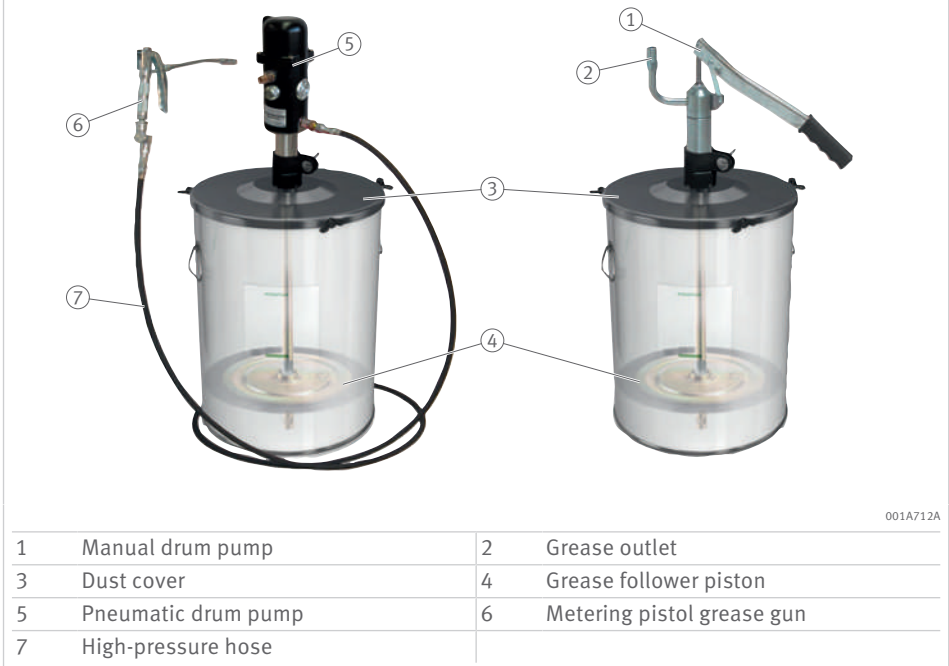

Pneumatic and manual drum pumps are suitable for delivering large quantities of grease under high pressure over long distances. However, they can also be used to fill the CONCEPT lubricators and associated cartridges.

When directly inserted in the original container, they facilitate economical use (less time required and optimal emptying). At the same time, they reduce the risk of lubricant contamination.



## 12.2.1 Pneumatic drum pump kits

## 81 Components

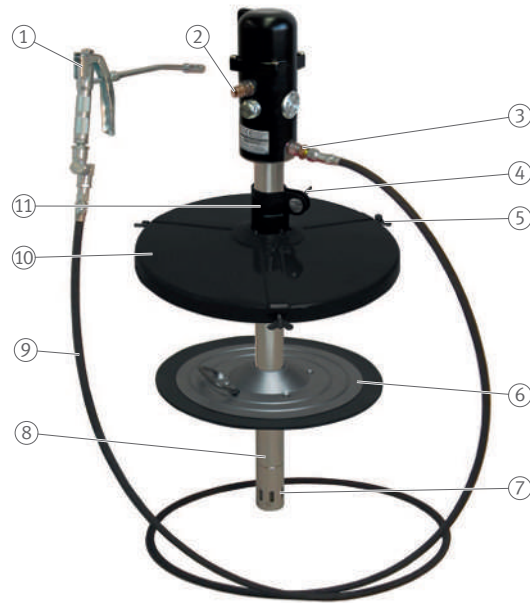

001A6006

1	Grease gun	2	Connector for compressed air supply
3	Grease outlet	4	Clamping screw
5	Wing bolt	6	Grease follower piston
7	Intake screen	8	Suction pipe
9	High-pressure hose	10	Dust cover
11	Gripper clamp		

The pneumatic drum pump kit ARCA-PUMP-BARREL..-SET-N is suitable for use with containers with a fill quantity of 18 kg, 25 kg, 50 kg or 180 kg.

It has numerous areas of application in the workshop:

- the filling of rolling bearings
- the greasing of gearboxes
- all applications that must be filled repeatedly with different grease quantities

## 77 Pneumatic drum pumps

Con- tainer	Inside diameter of the container		Ordering number	Ordering designation
	min	max		
kg	mm	mm		
18	265	285	301254532-0000-10	ARCA-PUMP-BARREL-18-SET-N
25	305	350	301254249-0000-10	ARCA-PUMP-BARREL-25-SET-N
50	385	410	301254311-0000-10	ARCA-PUMP-BARREL-50-SET-N
180	550	590	301254516-0000-10	ARCA-PUMP-BARREL-180-SET-N

 78 Technical data

Feature		ARCA-PUMP-BARREL...-SET-N			
		18	25	50	180
Container size		18 kg	25 kg	50 kg	200 kg
Inside diameter	min.	265 mm	305 mm	385 mm	550 mm
	max.	285 mm	350 mm	410 mm	590 mm
Suction pipe length		495 mm	495 mm	690 mm	950 mm
Suction pipe diameter		40 mm	40 mm	40 mm	40 mm
Mass		20,6 kg	20,7 kg	22,6 kg	25,7 kg
Air connector thread (internal thread)		RP 1/4"	RP 1/4"	RP 1/4"	RP 1/4"
Grease outlet thread (external thread)		R 1/4"	R 1/4"	R 1/4"	R 1/4"
Pressure ratio		1:55	1:55	1:55	1:55
Maximum delivery pressure		425 bar	425 bar	425 bar	425 bar
Air pressure		3 bar up to 8 bar	3 bar up to 8 bar	3 bar up to 8 bar	3 bar up to 8 bar
Maximum delivery rate with unrestricted discharge		1,1 kg/min	1,1 kg/min	1,1 kg/min	1,1 kg/min
Volume		85 dB(A)	85 dB(A)	85 dB(A)	85 dB(A)
High pressure hose length		3,5 m	3,5 m	3,5 m	3,5 m
Transport aid included in the scope of delivery		Yes	Yes	Yes	No

For the model ARCA-PUMP-BARREL-180-SET-N, the transport aid ARCA-PUMP-BARREL-180.TROLLEY-N can be ordered as an accessory.

## 12.2.2 Manual drum pump kits

## 82 Components



001A5D87

1	Grease outlet	2	Hand lever
3	Clamping screw	4	Wing bolt
5	Grease follower piston	6	Suction hole
7	Suction pipe	8	Dust cover
9	Gripper clamp		

The manual drum pump kit ARCA-PUMP-BARREL...FILL-SET-N is suitable for use with containers with a fill quantity of 18 kg, 25 kg, 50 kg oder 180 kg.

The manual drum pump is a cost-effective alternative to the pneumatic drum pump kit that can be used anywhere and is also used in particular for filling the CONCEPT1 lubricator and the cartridges from CONCEPT2, CONCEPT4 and CONCEPT8.

The adapter ARCALUB-C1.NIPPLE-REFILL-GREASE-R1/4 should be used to fill the CONCEPT1 lubricator ►18|▣14. Filling adapters are available for connecting the cartridges of CONCEPT2, CONCEPT4 and CONCEPT8 ►50|▣42.

A filling sleeve is included in the scope of delivery for filling grease guns via filling nipples in accordance with DIN 1283.

## 79 Manual drum pump

Con- tainer	Inside diameter of the container		Ordering number	Ordering designation
	min	max		
kg	mm	mm		
18	265	285	301254427-0000-10	ARCA-PUMP-BARREL-18.FILL-SET-N
25	305	350	301252580-0000-10	ARCA-PUMP-BARREL-25.FILL-SET-N
50	385	410	301254273-0000-10	ARCA-PUMP-BARREL-50.FILL-SET-N
180	550	590	301254460-0000-10	ARCA-PUMP-BARREL-180.FILL-SET-N

### 80 Technical data

Feature		ARCA-PUMP-BARREL...FILL-SET-N			
		18	25	50	180
Container size		18 kg	25 kg	50 kg	200 kg
Inside diameter	min.	265 mm	305 mm	385 mm	550 mm
	max.	285 mm	350 mm	410 mm	590 mm
Suction pipe length		535 mm	535 mm	800 mm	800 mm
Suction pipe diameter		40 mm	40 mm	40 mm	40 mm
Mass		4,0 kg	4,6 kg	8,0 kg	19,5 kg
Grease outlet thread (outside)		R 1/4"	R 1/4"	R 1/4"	R 1/4"
Filling sleeve for grease outlet included in the scope of delivery (inside)		R 1/4"	R 1/4"	R 1/4"	R 1/4"
Delivery rate per stroke		45 cm <sup>3</sup>	45 cm <sup>3</sup>	45 cm <sup>3</sup>	45 cm <sup>3</sup>
Maximum delivery pressure		30 bar	30 bar	30 bar	30 bar
Lever displacement		375 mm	375 mm	375 mm	375 mm
Transport aid included in the scope of delivery		no	no	no	no

### 12.2.3 Spare parts

Spare parts are available for the pneumatic drum pump and manual drum pump kits.

### 81 Replacement parts

Type	Set	Ordering number	Ordering designation
Grease follower piston	18	301254435-0000-10	ARCA-PUMP-BARREL-18.FP-N
	25	301252599-0000-10	ARCA-PUMP-BARREL-25.FP-N
	50	301254281-0000-10	ARCA-PUMP-BARREL-50.FP-N
	180	301254478-0000-10	ARCA-PUMP-BARREL-180.FP-N
Dust cover	18	301254443-0000-10	ARCA-PUMP-BARREL-18.LID-N
	25	301252602-0000-10	ARCA-PUMP-BARREL-25.LID-N
	50	301254290-0000-10	ARCA-PUMP-BARREL-50.LID-N
	180	301254486-0000-10	ARCA-PUMP-BARREL-180.LID-N
Manual drum pump	18	301253714-0000-10	ARCA-PUMP-BARREL-18.FILL-N
	25	301253714-0000-10	ARCA-PUMP-BARREL-18.FILL-N
	50	301254265-0000-10	ARCA-PUMP-BARREL-50.FILL-N
	180	301254451-0000-10	ARCA-PUMP-BARREL-180.FILL-N
Pneumatic drum pump	18	301254524-0000-10	ARCA-PUMP-BARREL-18-PUMP-N
	25	301254524-0000-10	ARCA-PUMP-BARREL-18-PUMP-N
	50	301254303-0000-10	ARCA-PUMP-BARREL-50-PUMP-N
	180	301254508-0000-10	ARCA-PUMP-BARREL-180-PUMP-N
High-pressure hose, 3,5 m		301253706-0000-10	ARCA-PUMP-BARREL.HOSE-3,5M-N
Grease gun, nozzle tube R 1/8"		301253684-0000-10	ARCA-PUMP-BARREL.GUN-N

## 12.2.4 Selection of Arcanol container sizes

83 Hobbock 18 kg, 25 kg and 50 kg



001A720A

A selection of Arcanol lubricants and container sizes is available.

82 Arcanol container sizes

Type	Mass	Ordering number	Ordering designation
	kg		
Arcanol LOAD150	18	301416893-0000-10	ARCANOL-LOAD150-18KG#N
Arcanol LOAD220	18	301416907-0000-10	ARCANOL-LOAD220-18KG#N
Arcanol LOAD400	18	301416915-0000-10	ARCANOL-LOAD400-18KG#N
Arcanol LOAD460	18	301417229-0000-10	ARCANOL-LOAD460-18KG#N
Arcanol LOAD1000	18	301416885-0000-10	ARCANOL-LOAD1000-18KG#N
Arcanol MOTION2	18	301417237-0000-10	ARCANOL-MOTION2-18KG#N
Arcanol MULTI2	18	301417245-0000-10	ARCANOL-MULTI2-18KG#N
Arcanol MULTI3	18	301417253-0000-10	ARCANOL-MULTI3-18KG#N
Arcanol MULTITOP	18	301417261-0000-10	ARCANOL-MULTITOP-18KG#N
Arcanol SPEED2,6	18	301417270-0000-10	ARCANOL-SPEED2,6-18KG#N
Arcanol TEMP90	18	097965677-0000-10	ARCANOL-TEMP90-18KG#N1
Arcanol TEMP120	18	301417288-0000-10	ARCANOL-TEMP120-18KG#N
Arcanol VIB3	18	301417296-0000-10	ARCANOL-VIB3-18KG#N
Arcanol FOOD2	25	019143630-0000-10	ARCANOL-FOOD2-25KG#K
Arcanol LOAD220	25	019143761-0000-10	ARCANOL-LOAD220-25KG#K
Arcanol LOAD400	25	019143800-0000-11	ARCANOL-LOAD400-25KG#K
Arcanol LOAD460	25	065827066-0000-10	ARCANOL-LOAD460-25KG#S
Arcanol MOTION2	25	080267009-0000-10	ARCANOL-MOTION2-25KG#S
Arcanol MULTI2	25	019143885-0000-10	ARCANOL-MULTI2-25KG#K
Arcanol MULTITOP	25	019144008-0000-11	ARCANOL-MULTITOP-25KG#K
Arcanol TEMP120	25	019144105-0000-10	ARCANOL-TEMP120-25KG#K
Arcanol LOAD150	50	059810025-0000-10	ARCANOL-LOAD150-50KG
Arcanol LOAD400	50	019143826-0000-11	ARCANOL-LOAD400-50KG
Arcanol LOAD460	50	065827120-0000-10	ARCANOL-LOAD460-50KG
Arcanol MOTION2	50	080267157-0000-10	ARCANOL-MOTION2-50KG
Arcanol TEMP110	50	038705478-0000-10	ARCANOL-TEMP110-50KG

Further information can be found in the following publication:

TPI 168 | Arcanol Rolling Bearing Greases |  
<https://www.schaeffler.de/std/1F66>

## 12.2.5 Accessories

### 12.2.5.1 Adapter

84 Adapter



001A724A

83 Adapter

Type	Ordering number	Ordering designation
Adapter	301253668-0000-10	ARCA-PUMP-BARREL.FP-ADAPTER-N

The ARCA-PUMP-BARREL.FP-ADAPTER-N is a reducer for the grease follower piston and ensures compatibility with drum pumps from other manufacturers with a suction pipe diameter of 30 mm.

84 Technical data

Feature	Value
Inside diameter	30 mm
Outside diameter	40 mm

### 12.2.5.2 Metering pistol grease gun

85 Metering pistol grease gun with flow rate measurement



001A722A

85 Metering pistol grease gun

Type	Ordering number	Ordering designation
Metering pistol grease gun	301253676-0000-10	ARCA-PUMP-BARREL.GUN-METER-N

The metering pistol grease gun with digital flow rate measurement allows precise grease feed into bearing positions and gearboxes.

The grease quantity is measured by volume. Before starting volume application, metering pistol grease guns must be set once with the aid of a precision balance.

### 86 Technical data

Feature	Value
Operating pressure	≤ 500 bar
Burst pressure	1000 bar
Delivery rate	≤ 2,5 kg/min
Counting accuracy	±3 %
Display accuracy	0,1 g
Max. display quantity	999 g
Z type swivel joint	No
Nozzle tube length	150mm
Display reset facility	Yes
Connector	R 1/4" (inside)
Mass	1,23 kg

#### 12.2.5.3 Transport aid

### 86 Transport aids



The ARCA-PUMP-BARREL...TROLLEY-N serves as a transport aid for filling devices and pneumatic drum pumps in various container sizes.

### 87 Transport aid

Type	Ordering number	Ordering designation
Containers < 50 kg	301254257-0000-10	ARCA-PUMP-BARREL-50.TROLLEY-N
Containers < 200 kg	301254494-0000-10	ARCA-PUMP-BARREL-180.TROLLEY-N

### 88 Technical data

Characteristic	ARCA-PUMP-BARREL-50.TROLLEY-N	ARCA-PUMP-BARREL-180.TROLLEY-N
Description	Transport aid for containers up to 50 kg	Transport aid for containers up to 200 kg
Material	Steel, zinc-coated	Steel, black powder coated
Length	700 mm	1000 mm
Width	520 mm	830 mm
Height	990 mm	1050 mm
Mass	11 kg	32 kg
Pump holder	Yes	No
Rollers	2 pieces, Ø 200 mm	2 pieces, Ø 200 mm
Swivel castors	No	1 piece, Ø 125 mm

**Schaeffler Technologies  
AG & Co. KG**

Georg-Schäfer-Straße 30  
97421 Schweinfurt  
Germany  
[www.schaeffler.de/en](http://www.schaeffler.de/en)  
[info.de@schaeffler.com](mailto:info.de@schaeffler.com)

In Germany:  
Phone 0180 5003872  
From other countries:  
Phone +49 9721 91-0

All information has been carefully compiled and checked by us, but we cannot guarantee complete accuracy. We reserve the right to make corrections. Therefore, please always check whether more up-to-date or amended information is available. This publication supersedes all deviating information from older publications. Printing, including excerpts, is only permitted with our approval.  
© Schaeffler Technologies AG & Co. KG  
TPI 252 / 06 / en-GB / DE / 2024-03